



Power Blower

Operator's Manual

MODEL

PB-1000

Serial Number 001001 & Up

WARNING **DANGER**



The muffler or catalytic muffler and surrounding cover may become extremely hot.

Always keep clear of exhaust and muffler area, otherwise serious personal injury may occur.

ADVERTENCIA

Los gases de escape del motor de este producto contienen productos químicos que según el Estado de California causan cáncer, defectos de nacimiento u otros daños del aparato reproductor.



WARNING **DANGER**

Read rules for safe operation and all instructions carefully. ECHO provides this Operator's Manual which must be read and understood for proper and safe operation.

INTRODUCTION

Welcome to the ECHO family. This ECHO product was designed and manufactured to provide long life and on-the-job-dependability. Read and understand this manual. You will find it easy to use and full of helpful operating tips and SAFETY messages.

WARNING DANGER

Read rules for safe operation and instructions carefully. ECHO provides this Operator's Manual which must be read and understood for proper and safe operation.

THE OPERATOR'S MANUAL --

contains specifications and information for operation, starting, stopping, maintenance, storage and assembly specific to this product.

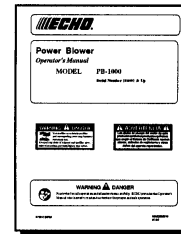

TABLE OF CONTENTS

Introduction	2	Maintenance	16
- The Operator's Manual	2	- Skill Levels	16
Manual Safety Symbols and Important Information ..	3	- Maintenance Intervals	16
Safety	3	- Air Filter	17
- Decals	3	- Fuel Filter	17
- Equipment	4	- Spark Plug	18
- Fuel	4	- Cooling System	18
- Personal Condition and Safety Equipment	5	- Exhaust System	19
- Safe Operation	6	- Carburetor Adjustment	20
- Extended Operation/Extreme Conditions	8	Troubleshooting	21
Description	9	Storage	22
Specifications	11	Servicing Information	24
Assembly	11	- Parts	24
- Install Blower Pipes	11	- Service	24
Pre-Operation	12	- ECHO Consumer Product Support	24
- Fuel	12	- Warranty Registration	24
Operation	13	- Additional or Replacement Manuals	24
- Starting Cold Engine	13		
- Starting Warm Engine	14		
- Stopping Engine	14		
- Operating Blower	15		

Specifications, descriptions and illustrative material in this literature are as accurate as known at the time of publication, but are subject to change without notice. Illustrations may include optional equipment and accessories, and may not include all standard equipment.

MANUAL SAFETY SYMBOLS AND IMPORTANT INFORMATION

Throughout this manual and on the product itself, you will find safety alerts and helpful, information messages preceded by symbols or key words. The following is an explanation of those symbols and key words and what they mean to you.



This symbol accompanied by the words **WARNING** and **DANGER** calls attention to an act or condition that can lead to serious personal injury to operator and bystanders.



The circle with the slash symbol means whatever is shown within the circle is prohibited.



IMPORTANT



NOTE

IMPORTANT The enclosed message provides information necessary for the protection of the unit.

NOTE This enclosed message provides tips for use, care and maintenance of the unit.

SAFETY DECALS

Locate these safety decals on your unit. The illustration shows their location. Make sure the decals are legible and that you understand and follow the instructions on them. If a decal cannot be read, a new one can be ordered from your ECHO dealer. See PARTS ORDERING instructions for specific information.

HOTDECAL

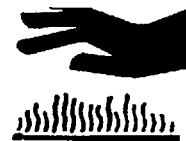

SPANISH DECAL

ADVERTENCIA

PELIGRO

Esta unidad puede ser peligrosa y producir lesiones personales graves si no se usa en forma adecuada. Para reducir el riesgo de lesionarse, los operadores, los ayudantes y los espectadores deben leer y comprender el Manual Del Operador que se entrega escrito en español.

ENGLISH TRANSLATION

WARNING

DANGER

This unit can be dangerous and cause serious injury if improperly used. To reduce injury risk to operator, helpers and bystanders, read and understand the Operator's Manual, which is provided in Spanish.

EQUIPMENT

Before operation a complete check of the unit must be performed:

- Check unit for loose/missing nuts, bolts and screws. Tighten and/or replace as needed.
- Inspect fuel lines, tank and area around carburetor for fuel leaks. **DO NOT** operate unit if leaks are found.

Spark Arrestor Muffler

- The spark arrestor muffler controls the exhaust noise and prevents hot, glowing particles of carbon from leaving the muffler. Make sure the spark arrestor screen is in good repair and properly seated in the muffler. (Refer to Exhaust System Maintenance pg. 19.)

Parts

- Do not use blower if any part is missing or damaged.
- Have repairs done only by an authorized ECHO Service dealer.
- Do not use any attachment, accessory or replacement part unless it is recommended in this Operator's Manual.

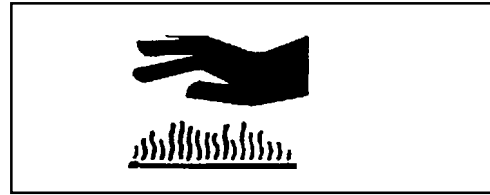
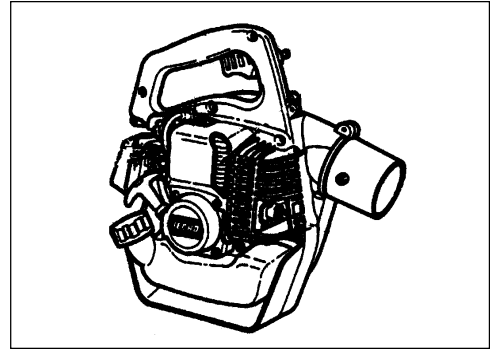

FUEL

WARNING **DANGER**

Fuel is **VERY** flammable. Use extreme care when mixing, storing or handling, otherwise serious personal injury may result.

- Use an approved fuel container.
- **DO NOT** smoke near fuel.
- **DO NOT** allow flames or sparks near fuel.
- Fuel tanks/cans may be under pressure. Always loosen fuel caps slowly allowing pressure to equalize.
- **NEVER** refuel a unit when the engine is **HOT!**
- **NEVER** refuel a unit with the engine running.
- **DO NOT** fill fuel tanks indoors. **ALWAYS** fill fuel tanks outdoors over bare ground.
- Securely tighten fuel cap after refueling.
- Inspect for fuel leakage. If fuel leakage is found, do not start or operate unit until leakage is repaired.

IMPORTANT

Spilled fuel is a leading cause of hydrocarbon emissions. Some states may require the use of automatic fuel shut-off containers to reduce fuel spillage. Contact your ECHO dealer for ordering information.



After Refueling;

- Wipe any spilled fuel from the unit.
- Move at least 3 m (10 ft.) from refueling location before starting.

After Use;

- DO NOT store a unit with fuel in its tank. Leaks can occur. Return unused fuel to an approved fuel storage container.

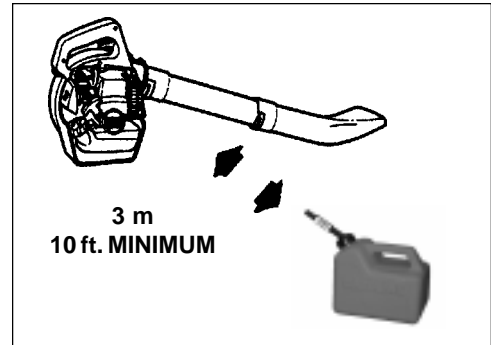

PERSONAL CONDITION AND SAFETY EQUIPMENT

WARNING  **DANGER**

Power Blower users risk injury to themselves and others if the power blower is used improperly and or safety precautions are not followed. Proper clothing and safety gear must be worn when operating a blower.

Physical Condition --

Your judgment and physical dexterity may not be good:

- if you are tired or sick,
- if you are taking medication,
- if you have taken alcohol or drugs.

Operate unit only if you are physically and mentally well.



Eye Protection --

Wear eye protection that meets ANSI Z87.1 or CE requirements whenever you operate the blower.

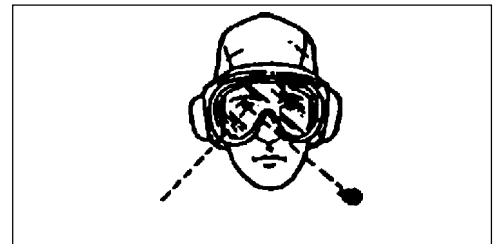

Hand Protection --

Wear no-slip, heavy duty work gloves to improve your grip on the blower handle. Gloves also reduce the transmission of machine vibration to your hands.

Breathing Protection --

Wear a face mask to protect against dust.

Hearing Protection --

ECHO recommends wearing hearing protection whenever unit is used.

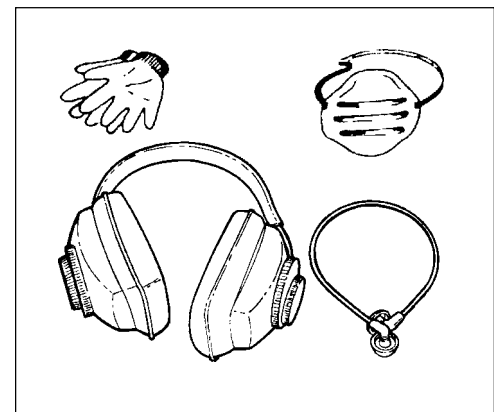

Proper Clothing --

Wear snug fitting, durable clothing;

- Pants should have long legs, shirts with long sleeves.
- **DO NOT WEAR SHORTS,**
- **DO NOT WEAR TIES, SCARVES, JEWELRY.**

Wear sturdy work shoes with nonskid soles;

- **DO NOT WEAR OPEN TOED SHOES,**
- **DO NOT OPERATE UNIT BAREFOOTED.**

Keep long hair away from engine and blower intake. Retain hair with cap or net.

Hot Humid Weather --

Heavy protective clothing can increase operator fatigue which may lead to heat stroke. Schedule heavy work for early morning or late afternoon hours when temperatures are cooler.

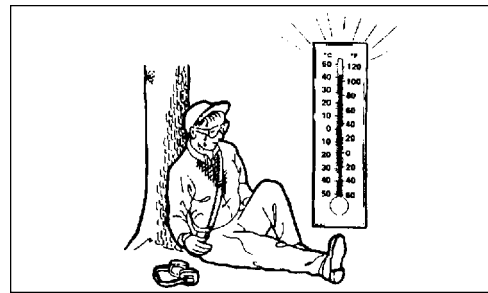

SAFE OPERATION

Determine Operation Area

- Review area to be cleared. Look for potential hazards such as stones or metal objects.
- Spectators and fellow workers must be warned, and children and animals prevented from coming nearer than 15 m (50 ft.) while the blower is in use.
- Take wind conditions into account: avoid open doors and windows.
- Provide all operators of this equipment with the Operator's Manual and instructions for safe operation.
- Do not point blower at people or animals.

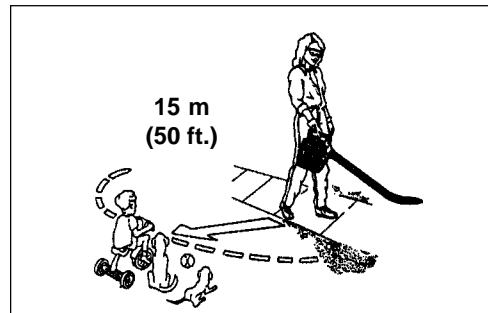

WARNING DANGER

Do not operate this product indoors or in inadequately ventilated areas. Engine exhaust contains poisonous emissions and can cause serious injury or death.

Use Proper Clothing & Equipment

- Before starting the unit, equip yourself and any other person working within the 15 m (50 ft.) Safety Zone with the required Protective Equipment and clothing.
- Keep long hair away from engine and blower intake. Retain hair with cap or net.
- Start unit on ground with throttle at idle. Check that blower pipe is not blocked by the ground or by any objects.

Keep A Firm Grip

- Hold handle with fingers together encircling the handle.

Keep A Solid Stance

- Maintain footing and balance at all times. Do not stand on slippery, uneven or unstable surfaces. Do not work in odd positions or on ladders.
- Do not perform Maintenance or Assembly procedures with engine running.

Noise Control

- Follow local noise regulations on sound levels and hours of operations. Use only during appropriate hours.
- Never use a higher speed setting than necessary to perform a task. The higher the engine speed the louder the blower noise.
- Be a good neighbor.

Avoid Hot Surfaces

- During operation, the muffler and surrounding cover may become extremely hot. Avoid contact during and immediately after operation. Always keep exhaust area clear of flammable debris. Allow the engine and muffler to completely cool before performing any maintenance activity.

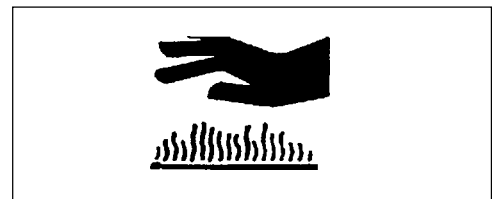

EXTENDED OPERATION/EXTREME CONDITIONS

Vibration and Cold --

It is believed that a condition called Raynaud's Phenomenon, which affects the fingers of certain individuals may be brought about by exposure to vibration and cold. Exposure to vibration and cold may cause tingling and burning sensations followed by loss of color and numbness in the fingers. The following precautions are strongly recommended because the minimum exposure which might trigger the ailment is unknown.

- Keep your body warm, especially the head, neck, feet, ankles, hands and wrists.
- Maintain good blood circulation by performing vigorous arm exercises during frequent work breaks and also by not smoking.
- Limit the hours of operation. Try to fill each day with jobs where operating the blower or other hand-held power equipment is not required.
- If you experience discomfort, redness and swelling of the fingers followed by whitening and loss of feeling, consult your physician before further exposing yourself to cold and vibration.

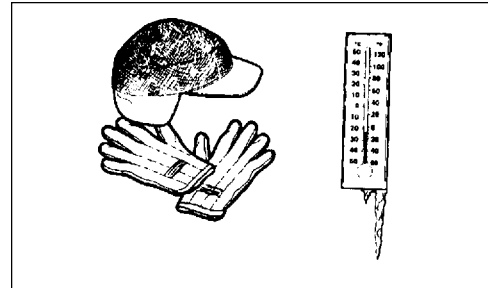

Repetitive Stress Injuries --

It is believed that overusing the muscles and tendons of the fingers, hands, arms and shoulders may cause soreness, swelling, numbness, weakness and extreme pain in those areas. Certain repetitive hand activities may put you at a high risk for developing a Repetitive Stress Injury (RSI). An extreme RSI condition is Carpal Tunnel Syndrome (CTS), which could occur when your wrist swells and squeezes a vital nerve that runs through the area. Some believe that prolonged exposure to vibration may contribute to CTS. CTS can cause severe pain for months or even years. To reduce the risk of RSI/CTS, do the following:

- Avoid using your wrist in a bent, extended or twisted position. Instead try to maintain a straight wrist position. Also, when grasping, use your whole hand, not just the thumb and index finger.
- Take periodic breaks to minimize repetition and rest your hands.
- Reduce the speed & force in which you do the repetitive movement.
- Do exercises to strengthen the hand and arm muscles.
- Immediately stop using all power equipment and consult a doctor if you feel tingling, numbness or pain in the fingers, hands, wrists or arms. The sooner RSI/CTS is diagnosed, the more likely permanent nerve and muscle damage can be prevented.

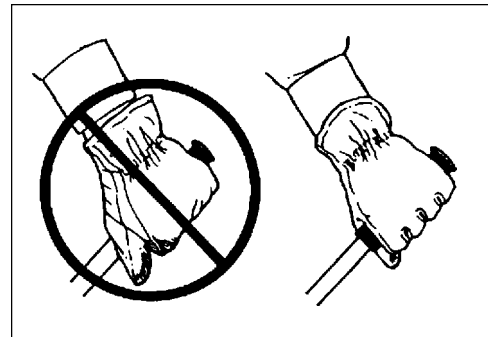

DESCRIPTION

CONTENTS

- 1 - Power Head
- 1 - Straight Pipe
- 1 - Pipes with Nozzle
- 1 - Operator's Manual
- 1 - Warranty Registration Card
- 1 - T-Wrench

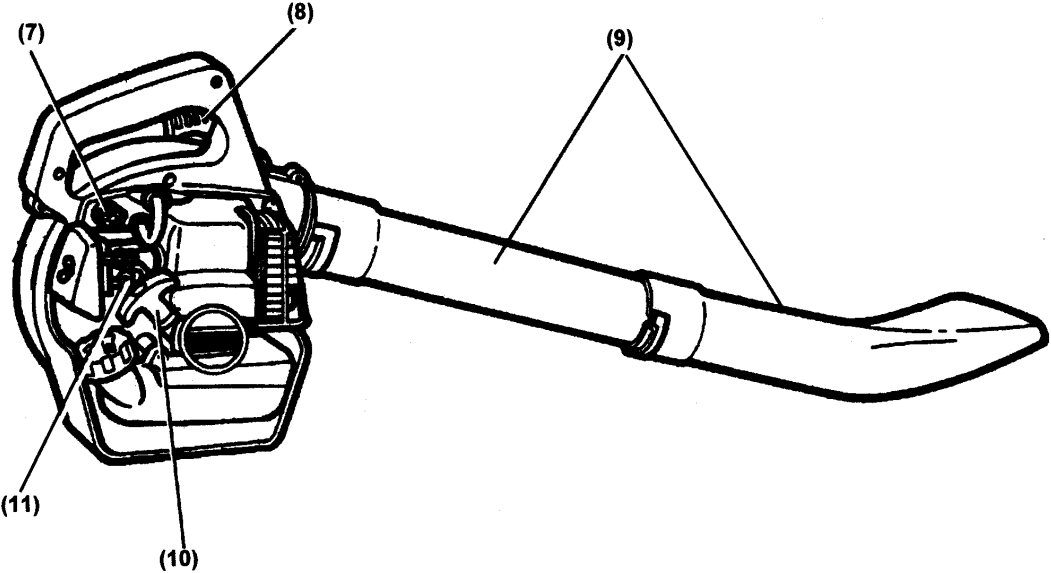
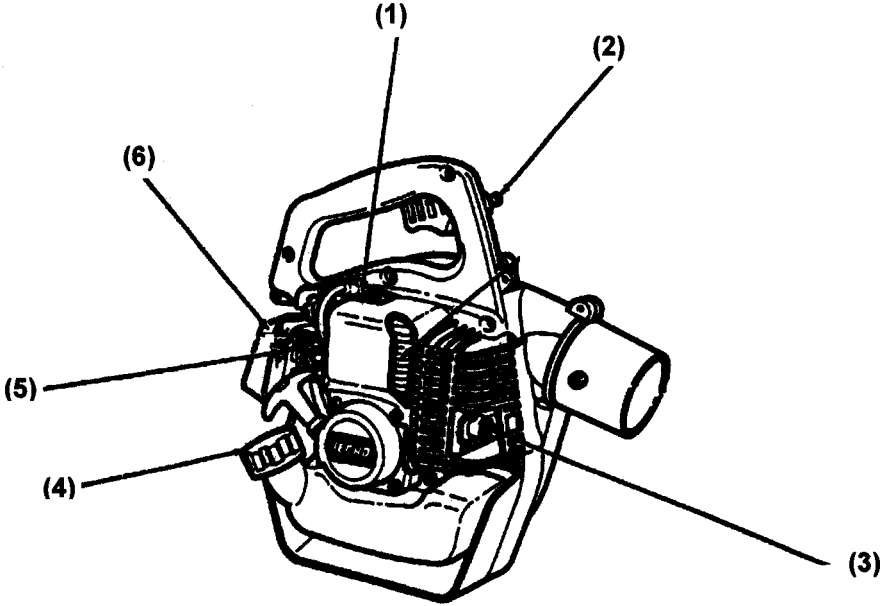
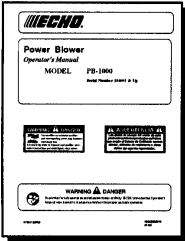

1. **SPARK PLUG** - Provides spark to ignite fuel mixture.
2. **IGNITION SWITCH** - "TOGGLE SWITCH" mounted on side of handle. Move switch **up** to **start** and **run**. Move **down** to stop.
3. **MUFFLER/SPARK ARRESTOR** - The spark arrestor muffler controls the exhaust noise while the spark arrestor prevents hot, glowing particles of carbon from leaving the muffler.
4. **FUEL TANK CAP** - Covers and seals fuel tank.
5. **CHOKE LEVER** - Lever is located on right side of the air cleaner. Move lever **DOWN** to close choke (starting position) and for emergency stopping. Move **UP** to open choke (run position).
6. **AIR CLEANER** - Contains replaceable felt element.
7. **THROTTLE POSITION KNOB** - Squeeze throttle trigger and turn knob counter clockwise to hold throttle trigger open. Squeeze throttle trigger again to return to idle speed.
8. **THROTTLE TRIGGER** - Spring loaded to return to idle when released if throttle position knob is not engaged.
9. **BLOWER PIPES** - Twist lock design.
10. **STARTER HANDLE** - Pull handle slowly until starter engages, then return handle slowly. **DO NOT** let handle snap back or damage to unit will occur.
11. **PRIMER BULB** - Pumping primer bulb before starting engine draws fresh fuel from the fuel tank priming the carburetor for starting. Pump primer bulb until fuel is visible and flows freely in the clear fuel tank return line. Pump bulb an additional 4 or 5 times.

SPECIFICATIONS

Dimensions	Length	325 mm (12.8 in.) w/o blower pipe
	Width	220 mm (8.7 in.)
	Height	330 mm (13.0 in.)
Weight w/pipes (dry)		3.3 kg (7.3 lb.)
Engine	Type	Air-cooled, two-stroke, single cylinder gasoline engine
	Bore	32.2 mm (1.268 in.)
	Stroke	26.0 mm (1.024 in.)
	Displacement	21.2 cc (1.29 cu. in.)
Exhaust System		* Spark arrestor muffler
Carburetor		ZAMA diaphragm model C1U w/purge
Ignition System	Spark Plug	NGK BPM-7A 0.65 mm (0.026 in.)
Fuel System	Fuel	Mixed (gasoline and oil)
	Fuel/Oil Ratio	50:1
	Gasoline	89 octane unleaded. Do not use fuel containing methyl alcohol, more than 10% ethyl alcohol or 15% MTBE.
	Oil	50:1 ECHO High Performance 2-stroke engine oil
	Fuel Tank Capacity	0.5 lit. (17 U.S. fl. oz.)
Starter System		Automatic rewind starter Centrifugal type

ASSEMBLY

WARNING  **DANGER**

Never perform maintenance or assembly procedures with engine running or serious personal injury may result.

INSTALL BLOWER PIPES

1. Align grooves in straight pipe with pegs on blower housing and slide pipe onto housing.
2. Turn straight pipe clockwise to lock it into place.
3. Repeat instructions to install curved pipe to straight pipe.

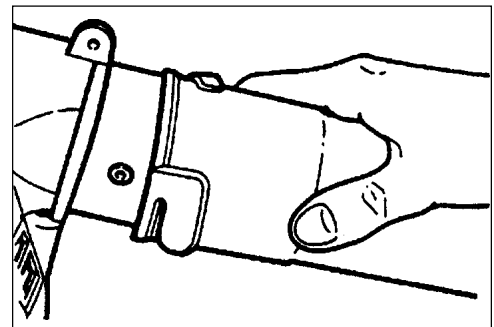

PRE-OPERATION

FUEL

Fuel Requirements --

Gasoline - Use 89 Octane [$\frac{R+M}{2}$] (mid grade or higher) gasoline known to be good quality. Gasoline may contain up to 15% MTBE (methyl tertiary-butyl ether). Gasohol containing methyl (wood) alcohol is **NOT** approved.

Two Stroke Oil - A two-stroke engine oil meeting ISO-L-EGD (ISO/CD 13738) and J.A.S.O. FC Standards, must be used. Echo brand Premium 50:1 oil meets these standards. Engine problems due to inadequate lubrication caused by failure to use an ISO-L-EGD and J.A.S.O. FC certified oil, such as Echo Premium 50:1 Two-stroke Oil, will void the two-stroke engine warranty.

IMPORTANT

Echo Premium 2-Stroke Oil may be mixed at 50:1 ratio for application in all Echo engines sold in the past regardless of ratio specified in those manuals.

Mixing Instructions

1. Fill an approved fuel container with half of the required amount of gasoline.
2. Add 2-stroke oil to gasoline.
3. Close container and shake to mix oil with gasoline.
4. Add remaining gasoline and remix.
5. Install fuel container cap and wipe any spilled fuel from container and surrounding area.

Handling Fuel

WARNING **DANGER**

Fuel is **VERY** flammable. Use extreme care when mixing, storing or handling or serious personal injury may result.

- Use an approved fuel container.
- **DO NOT** smoke near fuel.
- **DO NOT** allow flames or sparks near fuel.
- Fuel tanks/cans may be under pressure. Always loosen fuel caps slowly allowing pressure to equalize.
- **NEVER** refuel a unit when the engine is **HOT!**
- **NEVER** refuel a unit with the engine running.
- **DO NOT** fill fuel tanks indoors. **ALWAYS** fill fuel tanks outdoors over bare ground.
- Securely tighten fuel cap after refueling.
- Inspect for fuel leakage. If fuel leakage is found, do not start or operate unit until leakage is repaired.

IMPORTANT

Spilled fuel is a leading cause of hydrocarbon emissions. Some states may require the use of automatic fuel shut-off containers to reduce fuel spillage. Contact your ECHO dealer for ordering information.

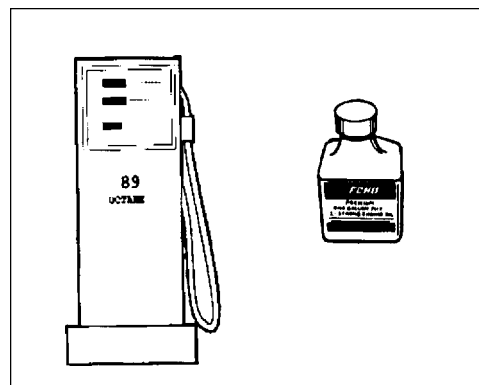

After Refueling -

- Wipe any spilled fuel from the unit.
- Move at least 3 m (10 ft.) from refueling location before starting.

After use -

- DO NOT store a unit with fuel in its tank. Leaks can occur. Return unused fuel to an approved fuel storage container.

Storage -

Fuel storage laws vary by locality. Contact your local government for the laws affecting your area. As a precaution, store fuel in an approved, air tight container. Store in a well ventilated, unoccupied building, away from sparks and flames. Do not store fuel longer than 30 days.

IMPORTANT

Stored fuel ages. Do not mix more fuel than you expect to use in thirty (30) days, ninety (90) days when a fuel stabilizer is added.

Stored two-stroke fuel may separate. ALWAYS shake fuel container thoroughly before each use.

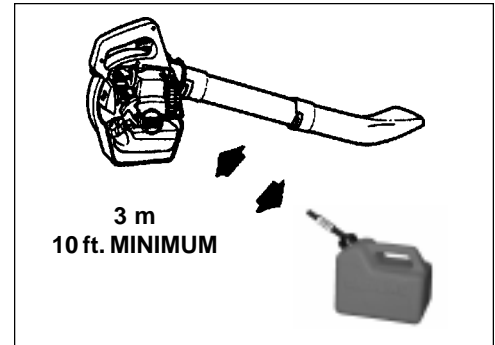

S	M	T	W	T	F	S
1	2	3	4	5	6	7
8	9	10	11	12	13	14
15	16	17	18	19	20	21
22	23	24	25	26	27	28
29	30	31				

OPERATION

- Provide all operators of this equipment with the Operator's Manual and instructions for safe operation.
- Check unit for loose nuts, bolts and screws daily.
- Recoil starter: Use short pulls - only 1/2-2/3 of rope length for starting. Do not allow the rope to snap back in. Always hold the unit firmly.

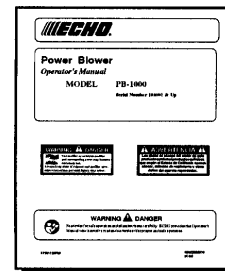

STARTING COLD ENGINE

1. Move ignition switch (A) to START/RUN position.

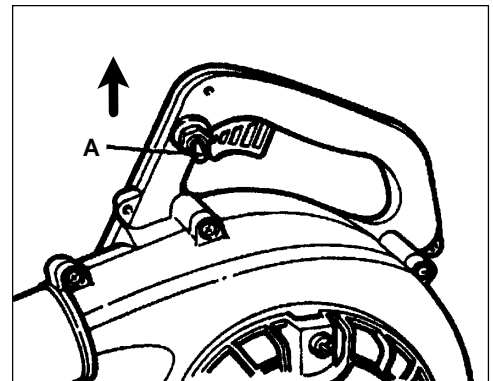

2. Pump primer bulb (B) until fuel is visible and flows freely in the clear fuel tank return line. Pump bulb an additional 4 or 5 times.
3. Close choke (C) (move choke lever up) and pull starter handle (D) until engine fires.
4. Open choke (C) and if necessary, restart engine. allow engine to warm up at idle for several minutes.

NOTE

If engine does not start after 4 pulls, repeat instructions.

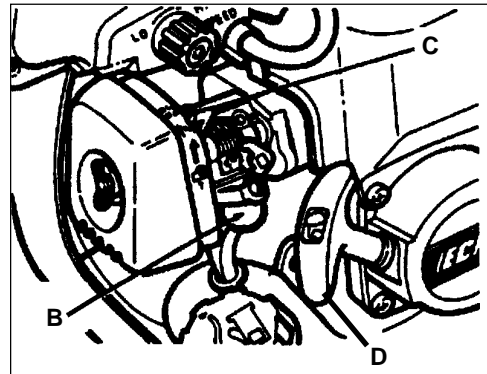

STARTING WARM ENGINE

1. Move ignition switch (A) to start, pull starter handle (D) and engine should start. Do not use choke (C).

NOTE

If engine does not start after 4 pulls, use cold start procedures.

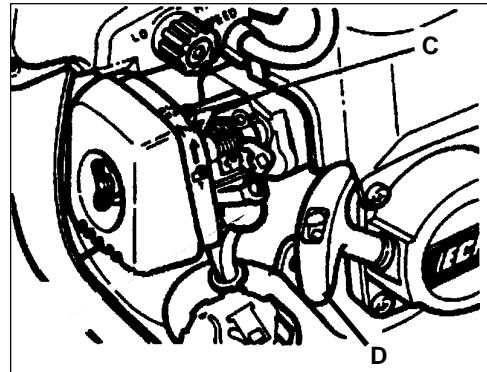
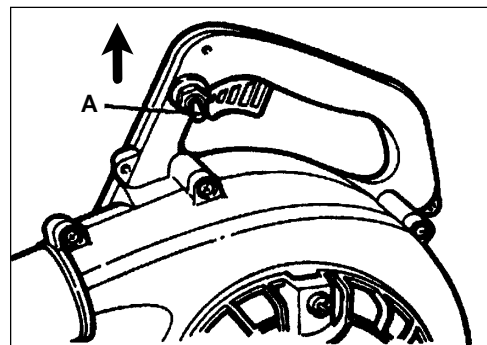

STOPPING ENGINE

1. Release throttle trigger (E) and allow engine to run at idle for a few minutes.
2. Move ignition switch (A) to "STOP" position.

WARNING  **DANGER**

If engine does not stop, shift choke lever to closed position. Check and repair ignition switch before starting engine again or serious personal injury may result.

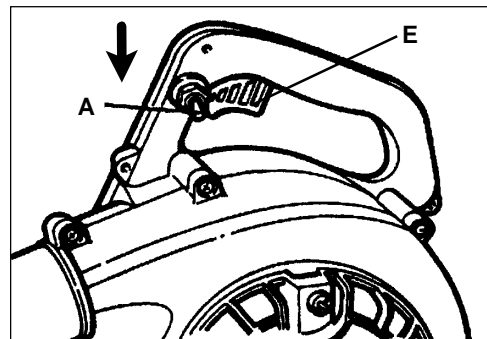

OPERATING BLOWER

WARNING  **DANGER**

Always wear safety glasses, hearing protection and a face filter mask or serious personal injury may result.

Do not point the blower pipe in the direction of people or pets.

Read the Safety Section carefully.

IMPORTANT

To avoid engine damage due to over revving, do not block blower pipe.

1. Use only during appropriate hours.
2. Make sure all pipes are installed.
3. Allow the engine to warm up at a fast idle for a few minutes.
4. Set engine speed with throttle position knob (F).

NOTE

Use lower speed to blow dry leaves from a lawn or flower bed. Additional speed may be necessary to clean grass and leaves from walks, patios and drives or to move gravel, dirt, snow, bottles or cans from a driveway, street, parking lot or stadium.

NOTE

Never use a higher speed setting than necessary to perform a task. Remember, the higher the engine speed, the louder the blower noise. Minimize dust by using blower at lower speeds. Keep debris on your property.
Be Smart - be a good neighbor.

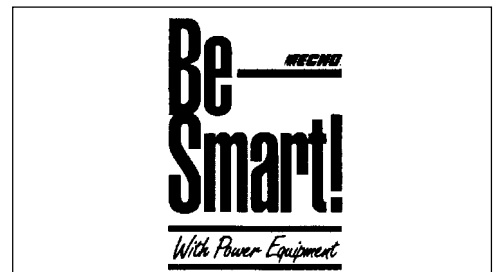
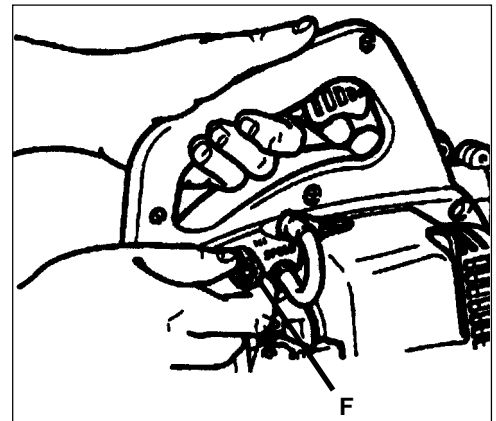

MAINTENANCE

WARNING DANGER

Do not perform maintenance on engine or muffler until engine and muffler are completely cool, otherwise serious personal injury may result.

Your ECHO blower is designed to provide many hours of trouble free service. Regular scheduled maintenance will help your blower achieve that goal. If you are unsure or are not equipped with the necessary tools, you may want to take your unit to an ECHO Service Dealer for maintenance. To help you decide whether you want to DO-IT-YOURSELF or have the ECHO Dealer do it, each maintenance task has been graded. If task is not listed, see your ECHO Dealer for repairs.

SKILL LEVEL

- Level 1** = Easy to do. Most required tools come with unit.
- Level 2** = Moderate difficulty. Some specialized tools may be required.
- Level 3** = Experience required. Specialized tools are required. Echo recommends the unit be returned to your Echo Dealer for servicing.

ECHO offers **REPOWER™** Maintenance Kits and Parts to make your maintenance job easier. Just below each task heading are listed the various part numbers required for that task. See your ECHO dealer for these parts.

MAINTENANCE INTERVALS

Component/System	Maintenance Procedure	Before Use	Every Refuel	Daily or Every 4 hours	Three Months or 100 hours	Six Months or 300 hours	Yearly or 600 hours	*Date Maintenance Performed
Air Filter	Clean	•		•				
	Replace				•			
Fuel Strainer	Clean/Replace				•			
Fuel Line	Inspect				•			
Carburetor	Inspect/Rebuild					•		
	Replace						• (1)	
Choke System	Inspect/Clean/Replace		•					
Cooling System	Inspect	•		•				
	Clean	•		•				
Muffler Spark Arrestor	Inspect				•			
	Clean				•			
Vacuum Bag	Inspect/Replace	•						
Starter Rope	Inspect/Clean	•						
Fuel Leaks	Inspect	•						
	Repair	•						
Spark Plug	Clean				•			
	Replace					•		
Ignition System	Clean/Replace	No Maintenance required for coil and flywheel						
Screw/Bolts/Nuts	Inspect/Tighten/Replace	•						

IMPORTANT

Time intervals shown are maximum. Actual use and your experience will determine the frequency of required maintenance.

*Record dates of monthly and yearly inspections.

(1) Replacement will be required for Commercial use after 600 hours. For Consumer use, cleaning every 6 months is required. Cleaning includes Rebuild Kits.

AIR FILTER

Level 1.

Tools required: Cleaning brush, 25 or 50 mm (1 or 2 in.) medium bristle paint brush.

Parts required: Air Filter P/N 13031004560

NOTE

Clean daily.

1. Close choke, remove wing nut, air cleaner cover and air filter.
2. Brush dust off filter.
3. Be sure filter still fits the cavity in the air cleaner cover.

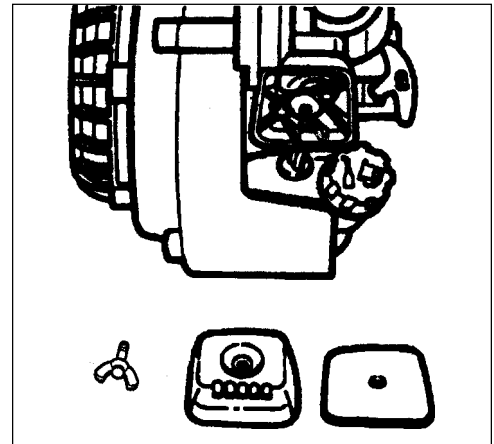
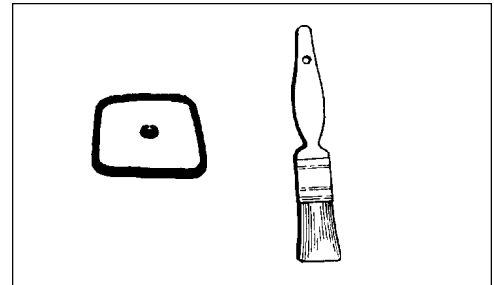

FUEL FILTER

Level 1.

Tools required: Fuel line hook. 203-254 mm (8-10 in.) length of wire with one end bent into a hook. Clean cloth, funnel, and an approved fuel container.

Parts required: Fuel Filter P/N 13120507320

NOTE

Check fuel strainer periodically.

IMPORTANT

Keep fuel tank clean - do not allow dirt or debris to enter fuel tank.

NOTE

A clogged fuel strainer will cause hard starting or poor engine performance.

1. Pick up the fuel filter through fuel tank opening with a piece of steel wire.
2. Remove old filter.
3. Install new filter.

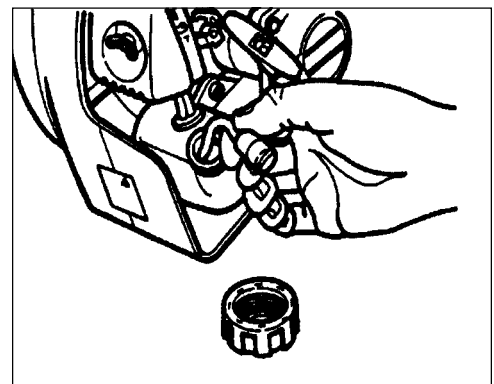
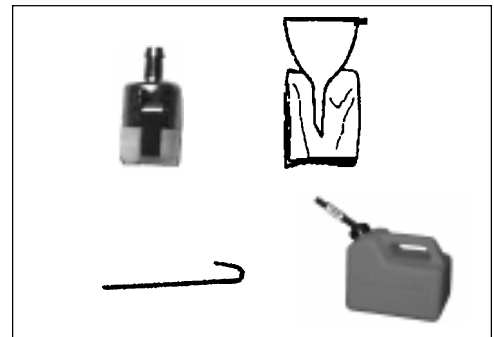

SPARK PLUG

Level 1.

Tools required: 3/4 in. Spark Plug deep socket, Feeler gauge (preferably a wire gauge),

Parts Required: Spark Plug ,NGK BPM-7A P/N 15901010630

1. Remove spark plug , and check for fouling, worn and rounded center electrode.
2. Clean the plug or replace with a new one. DO NOT sand blast to clean. Remaining sand will damage engine.
3. Adjust spark plug gap by bending outer electrode.
4. Tighten spark plug to 145-155 kg/cm (125-135 in. lb.).

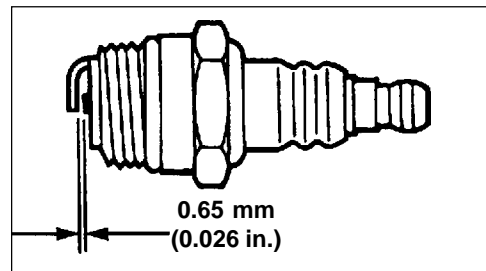
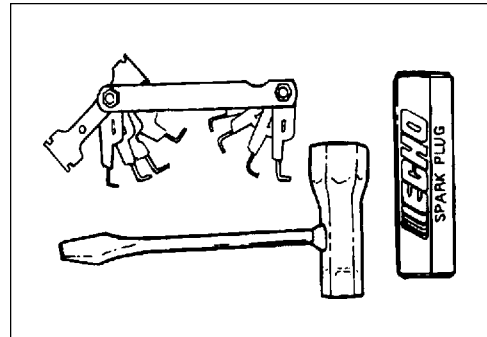

COOLING SYSTEMS CLEANING

Level 2.

Tools required: 25 - 50 mm (1 - 2 in.) medium bristle paint brush, Cross Head Screwdriver, Pointed Wood Stick.

Parts Required: None, if you are careful.

IMPORTANT

To maintain proper engine operating temperatures, cooling air must pass freely through the cylinder fin area. This flow of air carries combustion heat away from the engine.

Overheating and engine seizure can occur when:

- Air intakes are blocked, preventing cooling air from reaching the cylinder.
- Dust and grass build up on the outside of the cylinder. This build up insulates the engine and prevents the heat from leaving.

Removal of cooling passage blockages or cleaning of cooling fins is considered "Normal Maintenance". Any failure attributed to lack of maintenance is not warranted.

Cleaning Grill

Remove accumulated debris from crankcase intake grille above the fuel tank.

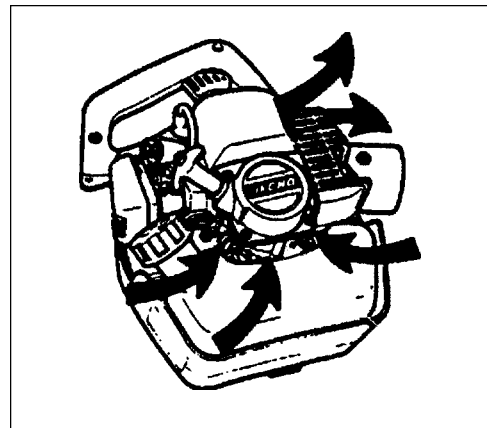
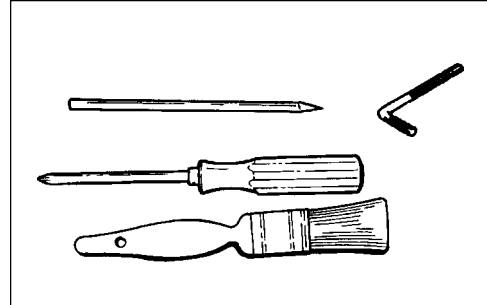

Cleaning Cylinder Fins

1. Remove spark plug.
2. Remove engine cover (seven screws) and clean cylinder fins to allow cooling air to pass freely.

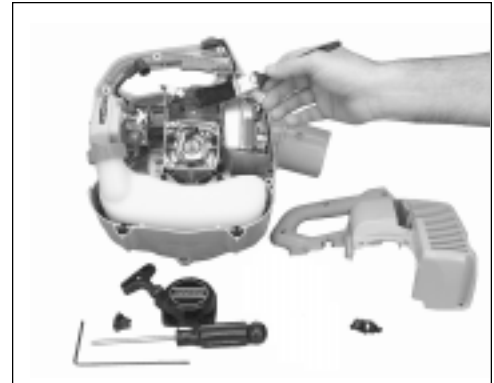

EXHAUST SYSTEM

Spark Arrestor Screen

Level 2.

Tools Required: Cross Head Screwdriver. Srench. 3 mm Allen wrench, 4mm Allen wrench.

Parts Required: Spark arrestor screen P/N 14586240630, gasket P/N 14586642031.

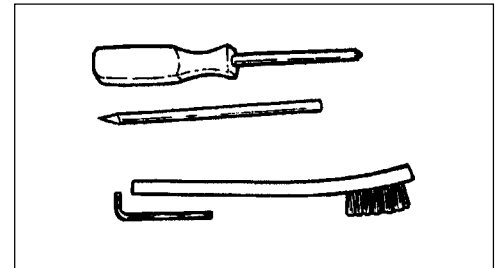

IMPORTANT

Carbon deposits in cylinder exhaust port and muffler will cause a drop in engine output and overheating. Muffler exhaust port and spark arrestor screen must be checked periodically.

1. Remove spark plug, recoil starter and engine cover (six screws).
2. Remove spark arrestor cover (A), gasket (B) and spark arrestor screen (C) from muffler. Replace screen if plugged with carbon deposits.
3. Install spark arrestor screen, gasket, diffuser and cover.
4. Be sure gasket seals muffler spark arrestor screen to muffler.

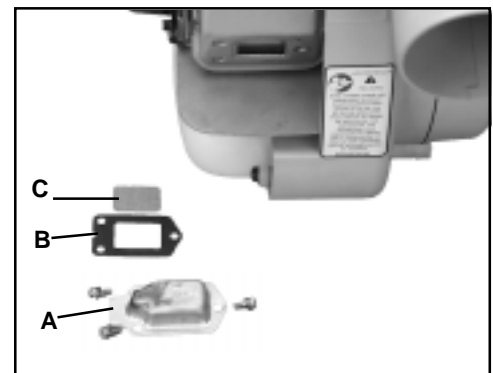

ADJUSTING CARBURETOR - GENERAL

Level 2.

Tools required: Screwdriver, tachometer.

Parts required: none.

NOTE

Do not adjust carburetor unless necessary. If you have difficulty, see your ECHO dealer.

Adjustment Screws

- | | |
|--------------------|---|
| Idle Speed (A) | Control throttle opening at idle. |
| Low (LO) Speed (B) | Controls amount of fuel at low speed and supplementary fuel for smooth progression from idle to high speed. |
| Hi (HI) Speed (C) | Controls amount of fuel at full throttle |

Before Adjustment

Check that:

- Air filter is clean and properly installed.
- Spark arrestor screen and exhaust port are free of carbon
- Blower pipes are installed

Initial Adjustment

NOTE

The needle screws have a sharp point. To avoid carburetor damage, do not use excessive force when seating needle in body.

1. Turn HI and LO adjustment screws (C) and (B) clockwise until seated lightly in carburetor body.
2. Turn (B) adjustment screw counter clockwise 1-1/8 turn.
3. Start engine and allow it to run at high idle until warm (approx. 2-3 minutes).

NOTE

Idle speed screw may have to be readjusted to keep engine from stalling.

Initial Adjustment

1. Slowly turn the (LO) adjustment screw (B) clockwise and note the position when the engine speed drops.
2. Turn the (LO) adjustment screw (B) counter clockwise and note the position when engine speed drops.
3. Set the screw midway between these points.

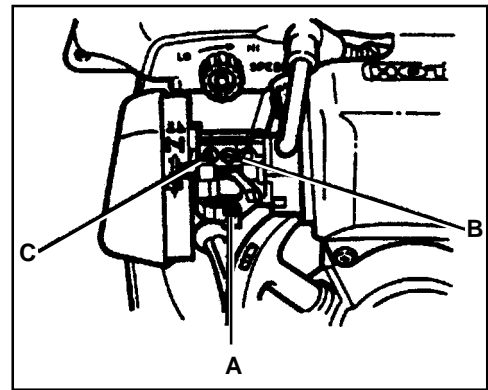
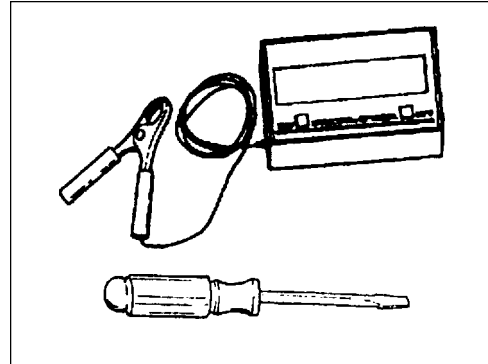

4. If tachometer is available, turn idle speed (A) clockwise until a speed of 2500-3400 RPM is achieved and engine idles without stalling.

High Speed Adjustment

NOTE

Engine must be at normal operating temperature.

1. Turn the (HI) adjustment screw (C) counter clockwise 1-1/4 turn.
2. While running the engine at full throttle, turn the (HI) adjustment screw (C) slowly clockwise until the engine runs smoothly.
3. Turn the screw counter clockwise 1/8 turn to obtain optimum fuel mixture for full power under load conditions.

NOTE

Check engine acceleration from idle to full throttle. If engine hesitates, turn LO speed screw (B) 1/16 to 1/8 of turn counter clockwise.

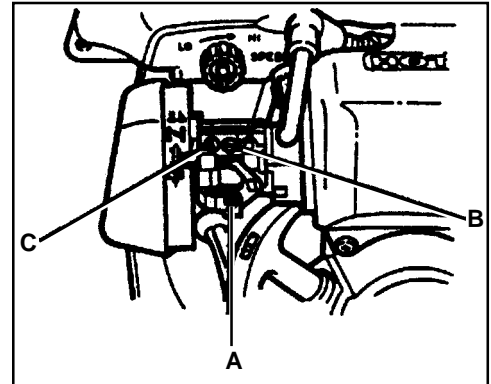

TROUBLESHOOTING

Problem		Cause	Remedy	
Engine - starts hard				
Engine - does not start				
Engine Cranks 	Fuel at carburetor	No fuel at carburetor	Fuel strainer clogged Fuel line clogged Carburetor	Clean Clean See your ECHO dealer
	Fuel at cylinder	No fuel at cylinder	Carburetor	See your ECHO dealer
		Muffler wet with fuel	Fuel Mixture is too rich	Open choke Clean/replace air filter Adjust carburetor See your ECHO dealer
	Spark at end of plug wire	No spark at end of plug wire	Stop switch off Electrical problem Interlock switch	Turn switch on See your ECHO dealer See your ECHO dealer
	Spark at plug	No spark at plug	Spark gap incorrect Covered with carbon Fouled with fuel Spark plug defective	Adjust 0.65mm (0.026in.) Clean or replace Clean or replace Replace plug
Engine does not crank		Internal engine problem	See your ECHO dealer	
Engine runs	Dies or accelerates poorly	Air filter dirty Fuel filter dirty Fuel vent plugged Spark plug Carburetor Cooling system plugged Spark arrestor screen plugged	Clean or replace Replace Replace Clean and adjust/replace Adjust Clean Clean	
Engine runs properly	Blower does not work, is weak or uneven	Blower Pipe clogged, loose or damaged	Unclog Tighten Replace	

WARNING



DANGER

Fuel vapors are **extremely** flammable and may cause fire and/or explosion. **Never** test for ignition spark near an open spark plug opening, otherwise serious personal injury may result.

STORAGE

WARNING  **DANGER**

During operation the muffler and surrounding cover become hot. Always keep exhaust area clear of flammable debris during transportation or when storing, otherwise serious property damage or personal injury may result.

Long Term Storage (Over 30 Days)

Do not store your unit for a prolonged period of time (30 days or longer) without performing protective storage maintenance which includes the following:

1. Store unit in a dry, dust free place, out of the reach of children.

WARNING  **DANGER**

Do not store in enclosure where fuel fumes may accumulate or reach an open flame or spark or serious personal injury may result.

2. Place the ignition switch in the "STOP" position.
3. Remove accumulation of grease, oil, dirt and debris from exterior of unit.
4. Perform all periodic lubrication and services that are required.
5. Tighten all screws and nuts.
6. **Drain** the fuel tank **completely** and pull the starter handle several times to remove fuel from the carburetor.
7. Remove the spark plug and pour 7cc (1/4 oz., 1/2 tablespoon) of fresh, clean ECHO 2-stroke engine oil into the cylinder through the spark plug hole.
 - A. Place a clean cloth over the spark plug hole.
 - B. Pull the recoil starter handle 2-3 times to distribute the oil inside the engine.
 - C. Observe the piston location through the spark plug hole. Pull the recoil handle slowly until the piston reaches the top of its travel and leave it there.
8. Install the spark plug (do not connect ignition cable).
9. Remove blower pipe assembly from unit.

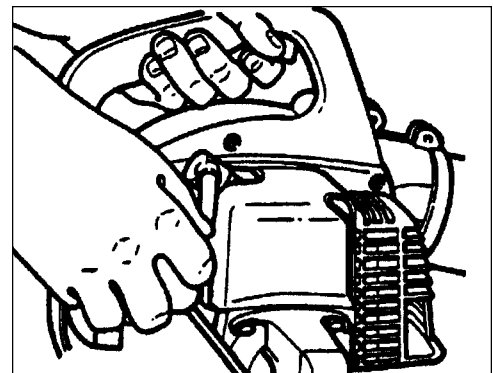
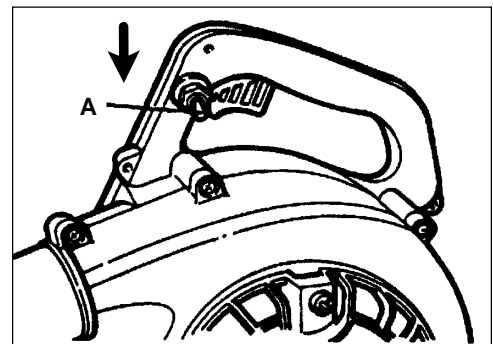

SERVICING INFORMATION

PARTS

Genuine ECHO Parts and ECHO REPOWER™ Parts and Assemblies for your ECHO products are available only from an Authorized ECHO Dealer. When you do need to buy parts **always** have the Model Number, Type number and Serial Number of the unit with you. You can find all three numbers on the engine housing. For future reference, write them in the space provided below.

Model No. _____ Type No. _____ SN. _____

SERVICE

Service of this product during the warranty period must be performed by an Authorized ECHO Service Dealer. For the name and address of the Authorized ECHO Service Dealer nearest you, ask your retailer or call: 1-800-432-ECHO (3246). Dealer information is also available on our Web Site. When presenting your unit for Warranty service/repairs, proof of purchase is required.

ECHO CONSUMER PRODUCT SUPPORT

If you require assistance or have questions concerning the application, operation or maintenance of this product you may call the ECHO Consumer Product Support Department at 1-800-673-1558 from 8:00 am to 5:00 pm (Central Standard Time) Monday through Friday. Before calling, please know the model and serial number of your unit to help your Consumer Product Support Representative.

WARRANTY REGISTRATION

You may register your Echo equipment using the warranty registration card or register on-line at www.echo-usa.com. Registering provides a direct link between you and ECHO if we find it necessary to contact you.

ADDITIONAL OR REPLACEMENT MANUALS

Safety Manuals in English/Spanish or English/French are available, free of charge, from your ECHO dealer or at www.echo-usa.com.

Operator's and Parts Manuals are available by:

- Downloading free from www.echo-usa.com
- Purchasing from your Echo Dealer.
- Sending a check or money order for \$2.00 per Parts Catalog or \$1.50 per Operator's Manual made payable to ECHO, INCORPORATED. State on a sheet of paper the model number and serial number of the ECHO unit you have, part number of the manual (if known), your name and address and mail to address above.

Safety Videos are available from your Echo dealer. A \$5.00 shipping charge will be required for each video.

Available Parts Catalog

PB-1000 S/N001001 & UP Part Number 99922202410

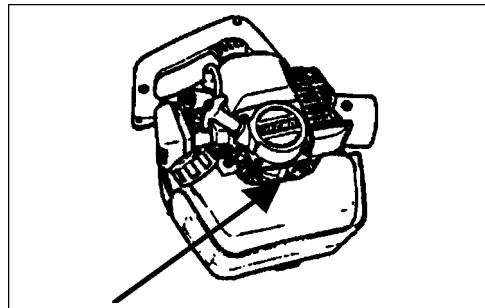

DEALER?
Call
1-800-432-ECHO
or
www.echo-usa.com

**CONSUMER PRODUCT
SUPPORT**
1-800-673-1558
8 - 5 Mon - Fri C.S.T.

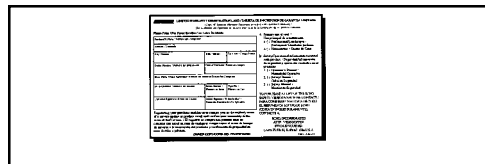

ECHO
ECHO, INCORPORATED
400 OAKWOOD ROAD
LAKE ZURICH, IL 60047
www.echo-usa.com