



OPERATOR'S MANUAL 3 INCH CHIPPER SHREDDER

SC-3013

WARNING



*Read and understand all provided literature before use.
Failure to do so could result in serious injury.*

WARNING

*Cancer and Reproductive Harm
www.P65Warnings.ca.gov*

Before You Begin

DEAR ECHO® CUSTOMER

Thank you for purchasing an ECHO product. The ECHO line is designed, tested, and manufactured to give years of dependable performance. To keep your machine operating at peak efficiency, it is necessary to adjust it correctly and make regular inspections. The following pages will assist you in the operation and maintenance of your machine. Please read and understand this manual before operating your machine.

ECHO Consumer Product Support

If you require assistance or have questions concerning the application, operation, or maintenance of this product, call the ECHO Consumer Product Support Department at 1-800-432-ECHO (3246) from 8:00 am to 5:00 pm (Central Standard Time) Monday through Friday. Before calling, please know the model and serial number of your unit.

This document is based on information available at the time of its publication. ECHO is continually making improvements and developing new equipment. In doing so, we reserve the right to make changes or add improvements to our product without obligation for equipment previously sold.

Product Registration

Register your ECHO equipment on-line at www.echo-usa.com or by filling out the product registration sheet included in this manual. Registering your product confirms warranty coverage and provides a direct link to ECHO if we find it necessary to contact you.

SERVICE

Service of this product during the warranty period must be performed by an Authorized ECHO Service Dealer. For the name and address of the Authorized ECHO Service Dealer nearest you, ask your retailer or call: 1-800-432-ECHO (3246). Dealer information is also available on our Web Site www.echo-usa.com. When presenting your unit for Warranty service/repairs, proof of purchase is required.

FOR ENGINE SERVICE OR PARTS

For engine service or parts, contact your nearest authorized engine dealer. ECHO does not handle any parts, repairs or warranties for engines.

PARTS/SERIAL NUMBER

Genuine ECHO Parts and Assemblies for your ECHO products are available only from an Authorized ECHO Dealer. When you do need to buy parts always have the Model Number and Serial Number of the unit with you. For future reference write them in the space provided below.

Model No. _____

Serial No. _____

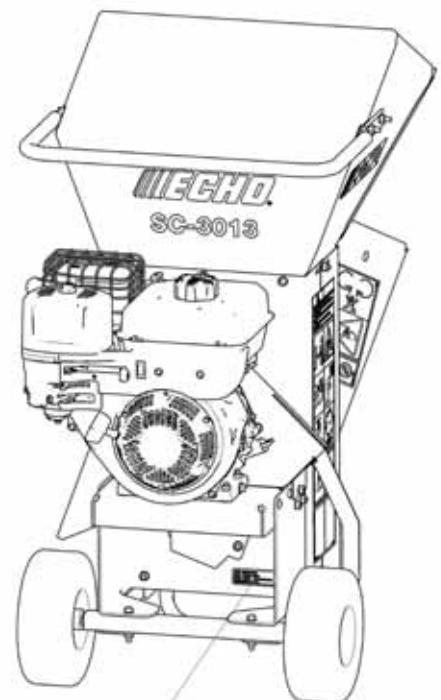
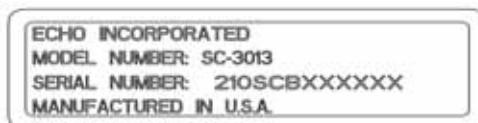

Serial Number Location

ADDITIONAL LITERATURE

In addition to finding information online, information is available from your Authorized ECHO Service Dealer, or by contacting

ECHO Inc.,

400 Oakwood Road, Lake Zurich, IL 60047

1-800-432-ECHO (3246)

©2020 ECHO Incorporated. All Rights Reserved..

WARRANTY**Limited Warranty Statement**

ECHO Incorporated warrants to the original retail purchaser that this ECHO® brand outdoor product is free from defects in material and workmanship and agrees to repair or replace at ECHO Incorporated's discretion, any defective product free of charge within these time periods from the date of purchase.

- 3 Year Consumer/Homeowner
- 1 Year Commercial
- 90 Days – For Rental Use
- 90 Days Accessories and Replacement Parts

This warranty extends to the original retail purchaser only and commences on the date of the original retail purchase. Any part of this product found, in the reasonable judgment of ECHO Incorporated, to be defective in material or workmanship will be repaired or replaced without charge for parts and labor by an authorized ECHO dealer. Repair parts and accessories replaced under this warranty are warranted only for the balance of the original warranty period.

The product, including any defective part, must be returned to an authorized ECHO dealer within the warranty period. The expense of delivering the product to the dealer for warranty work and the expense of returning it back to the owner after repair or replacement will be paid by the owner. ECHO Incorporated's responsibility in respect to claims is limited to making the required repairs or replacements and no claim of breach of warranty shall be cause for cancellation or rescission of the contract of sale of any ECHO brand outdoor product. Proof of purchase will be required by the dealer to substantiate any warranty claim. All warranty work must be performed by an authorized ECHO dealer.

This warranty does not cover any product that has been subject to misuse, neglect, negligence, or accident, or that has been operated in any way contrary to the operating instructions as specified in the Operator's Manual. This warranty does not apply to any damage to the product that is the result of improper maintenance or to any product that has been altered or modified. The warranty does not extend to repairs made necessary by normal wear or by the use of parts or accessories which are either incompatible with the ECHO brand outdoor product, or that adversely affect its operation, performance, or durability. In addition, this warranty does not cover wear to normal items such as, but not limited to:

- A. Tune-ups – Air filters, gas filters, carburetors, spark plugs, filters, oil changes
- B. Wear items – Recoil starter rope, wheels, bearings, belts, pulleys, chipper blades, shredder flails or knives.
- C. **IMPORTANT:** Some components not covered under this warranty may still be covered by a separate warranty issued by the engine manufacturer. Please see the Engine Manufacturer Warranty (if any) supplied with this product for further details.

ECHO Incorporated reserves the right to change or improve the design of this product without assuming any obligation to modify any product previously manufactured.

All implied warranties are limited in duration to the stated warranty period. Accordingly, any such implied warranties including merchantability, fitness for a particular purpose, or otherwise, are disclaimed in their entirety after the expiration of the appropriate three-year, one-year, or 90 day warranty period. ECHO incorporated's obligation under this warranty is strictly and exclusively limited to the repair or replacement of defective parts and ECHO incorporated does not assume or authorize anyone to assume for them any other obligation. Some states do not allow limitations on how long an implied warranty lasts, so the above limitation may not apply to you. ECHO incorporated assumes no responsibility for incidental, consequential, or other damages including, but not limited to, expense of returning the product to an authorized dealer for ECHO brand outdoor products and expense of delivering it back to the owner, mechanic's travel time, telephone or telegram charges, rental of a like product during the time warranty service is being performed, travel, loss or damage to personal property, loss of revenue, loss of use of the product, loss of time, or inconvenience. Some states do not allow the exclusion or limitation of incidental or consequential damages, so the above limitation or exclusion may not apply to you.

This warranty gives you specific legal rights, and you may also have other rights which vary from state to state.

This warranty applies to ECHO brand Chipper Shredders and Wheeled Trimmers manufactured by or for ECHO Incorporated and sold in the United States and Canada.

To locate your nearest authorized ECHO dealer, visit www.ECHO-usa.com or dial 1-800-432-ECHO (3246).

TABLE OF CONTENTS

1 SAFETY	1	5.3 CHIPPER BLADES MAINTENANCE	14
1.1 SAFETY ALERT SYMBOL	1	5.4 REMOVING THE BLADES	14
1.2 FIRE HAZARD INFORMATION	1	5.5 SHARPENING THE BLADES	15
1.3 BEFORE OPERATING	2	5.6 INSTALLING THE BLADES	15
1.4 OPERATION SAFETY	2	5.7 SHREDDER KNIVES MAINTENANCE	16
1.5 MAINTENANCE/STORAGE SAFETY	3	5.8 REMOVING THE SHREDDER KNIVES	16
1.6 SAFETY DECALS	4	5.9 ADJUSTING THE CHIPPER ANVIL	16
1.7 SAFETY DECAL LOCATIONS	5	5.10 CLEARING A PLUGGED ROTOR	17
2 ASSEMBLY	6	5.11 CHANGING THE DISCHARGE SCREEN	17
2.1 ASSEMBLY	6	5.12 BELT GUIDE ADJUSTMENTS	18
2.2 ADD OIL TO ENGINE	7	5.13 DRIVE BELTS	19
2.3 FILL THE FUEL TANK	7	5.14 REMOVING THE ROTOR	19
3 FEATURES & CONTROLS	8	5.15 CHANGE OIL	20
4 OPERATION	10	5.16 LUBRICATION	20
4.1 STARTING ENGINE	10	6 TROUBLESHOOTING	21
4.2 OPERATING THE CHIPPER	10	7 SPECIFICATIONS	23
4.3 CHIPPER OPERATION GUIDELINES	11	7.1 BOLT TORQUE	24
4.4 SLOWING AND STOPPING THE CHIPPER ROTOR AND ENGINE	12	8 OPTIONS	25
5 SERVICE & MAINTENANCE	13	9 PRODUCT REGISTRATION	27
5.1 MAINTENANCE SCHEDULE	13		
5.2 ROTOR LOCK	14		

1 SAFETY

Section

1.1 SAFETY ALERT SYMBOL



The Owner/Operator's manual uses this symbol to alert you of potential hazards. Whenever you see this symbol, read and obey the safety message that follows it. Failure to obey the safety message could result in personal injury, death or property damage.



DANGER



Indicates an imminently hazardous situation that, if not avoided, will result in death or serious injury.



WARNING



Indicates a potentially hazardous situation that, if not avoided, could result in death or serious injury.



CAUTION



Indicates a potentially hazardous situation that, if not avoided, may result in minor or moderate injury.

1.2 FIRE HAZARD INFORMATION

Operation of this equipment may create sparks that can start fires around dry vegetation. This unit may be equipped with a spark arrester to prevent discharge of hot particles from the engine. The spark arrester may be a standard or an optional part, depending on the engine type. In some areas, it is illegal to operate an engine without a spark arrester. Check local, state, and federal laws and regulations.



A spark arrester is available from authorized servicing dealers.

The engine on your power equipment, like most outdoor power equipment, is an internal combustion engine that burns gasoline or diesel fuel (hydrocarbons). If operating your power equipment in affected areas, it must be equipped with a spark arrester in continuous effective working order. The spark arrester must be attached to the engine exhaust system in such a manner that flames or heat from the system will not ignite flammable material.

Failure of the owner/operator of the equipment to comply with federal, state, and local laws may subject him or her to fines and/or other penalties. Contact your local fire marshal or forest service for specific information about which regulations apply in your area.

The standard muffler installed on the engine is spark arrester capable. Spark arrestors require regular maintenance. See the Service & Maintenance section of this manual for more information.

Contact local fire authorities for laws or regulations regarding fire prevention requirements.

1.3 BEFORE OPERATING

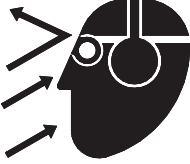
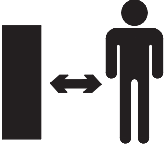

1. Read and understand this owner's manual. Be completely familiar with the controls and the proper use of this equipment.
2. Familiarize yourself with all of the safety and operating decals on this equipment and on any of its attachments or accessories.
3. Keep safety decals clean and legible. Replace missing or illegible safety decals.
4. Obtain and wear safety glasses and use hearing protection at all times when operating this machine. 
5. Avoid wearing loose fitted clothing. Never operate this machine while wearing clothing with drawstrings that could wrap around or get caught in the machine.
6. Do not operate this machine if you are under the influence of alcohol, medications, or substances that can affect your vision, balance or judgement. Do not operate if tired or ill. You must be in good health to operate this machine safely.
7. Do not operate this equipment in the vicinity of bystanders. Keep the area of operation clear of all persons, particularly small children. It is recommended that bystanders keep at least 50 feet (15 meters) away from the area of operation. 
8. Do not allow children to operate this equipment.
9. Use only in daylight or good artificial light.
10. Do not run this equipment in an enclosed area. Engine exhaust contains carbon monoxide gas, a deadly poison that is odorless, colorless and tasteless. Do not operate this equipment in or near buildings, windows or air conditioners.
11. Always use an approved fuel container. Do not remove gas cap or add fuel when engine is running. Add fuel to a cool engine only.
12. Do not fill fuel tank indoors. Keep open flames, sparks, smoking materials and other sources of combustion away from fuel.

13. Do not operate machine without shields in place. Failure to do so may cause serious injury or death.
14. Keep all guards, deflectors, and shields in good working condition.
15. Before inspecting or servicing any part of this machine, shut off the machine and make sure all moving parts have come to a complete stop. Disconnect the battery and remove the ignition key where applicable.
16. Check that all screws, nuts, bolts, and other fasteners are secured, tightened and in proper working condition before starting the machine.
17. Do not transport or move machine while it is operating or running.

1.4 OPERATION SAFETY

1. Always stand clear of discharge area when operating this machine. Keep face and body away from feed and discharge openings.
2. Keep hands and feet out of feed and discharge openings while machine is operating to avoid serious personal injury. Stop and allow machine to come to a complete stop before clearing obstructions.
3. Set up your work site so you are not endangering traffic and the public. Take great care to provide adequate warnings. 
4. Do not climb on machine when operating. Keep proper balance and footing at all times.
5. Check cutting chamber to verify it is empty before starting the machine.
6. The rotor will continue to rotate after being disengaged. Shut off the machine and make sure all moving parts have come to a complete stop before inspecting or servicing any part of the machine. Disconnect the battery and remove the ignition key if applicable.
7. Do not insert branches with a diameter larger than the max chipper capacity into machine or machine damage may occur.
8. When feeding material into machine, do not allow metal, rocks, bottles, cans or any other foreign material to be fed into the machine.

9. Ensure debris does not blow into traffic, parked cars, or pedestrians.
10. Keep the machine clear of debris and other accumulations.
11. Do not allow processed material to build up in the discharge area. This may prevent proper discharge and can result in kickback of material through the feed opening.
12. If the machine becomes clogged, the cutting mechanism strikes any foreign object, or the machine starts vibrating or making an unusual noise, shut off machine immediately and make sure all moving parts have come to a complete stop. Disconnect the battery and remove the ignition key if applicable. After the machine stops: A) Inspect for damage, B) Replace or repair any damaged parts, and C) Check for and tighten any loose parts.
13. On electric start models, disconnect cables from battery before doing any inspection or service. Remove key.
14. Check blade bolts for proper torque after every 8 hours of operation. Check blades and rotate or resharpen daily or as required to keep blades sharp. Failure to do so may cause poor performance, damage or personal injury and will void the machine warranty.

1.5 MAINTENANCE/STORAGE SAFETY

1. Before inspecting, servicing, storing, or changing an accessory, shut off the machine and make sure all moving parts have come to a complete stop. Disconnect the battery and remove the ignition key where applicable.
2. Replace any missing or unreadable safety decals. Refer to the safety decal section for part numbers.
3. Allow machine to cool before storing in an enclosure.
4. Store the machine out of reach of children and where fuel vapors will not reach an open flame or spark.
5. Never store this machine with fuel in the fuel tank inside a building where fumes may be ignited by an open flame or spark. Ignition sources can be hot water and space heaters, furnaces, clothes dryers, stoves, electric motors, etc.
6. Drain the fuel and dispose of it in a safe manner for storage periods of three months or more.

1.6 SAFETY DECALS

See Section 1.7 for decal locations. Familiarize yourself with all of the safety and operating decals on the machine and the associated hazards. See the engine owner’s manual or contact the engine manufacturer for engine safety instructions and decals.

1 YH653000170



Do not operate machine without shields in place. Failure to do so may cause serious injury or death.

2 YH653000180



Keep hands and feet out of inlet and discharge openings while machine is operating to avoid serious personal injury. Stop and allow machine to come to a complete stop before clearing obstructions.

3 YH653000190



Do not insert branches larger than 3/4 inch into shredder or machine damage may occur.

4 YH653000210



Do not insert branches larger than 3 inches in diameter into chipper. Machine damage may occur. Refer to owners manual for operating instructions and recommendations.

Keep hands and feet out of inlet and discharge openings while machine is operating to avoid serious personal injury. Stop and allow machine to come to a complete stop before clearing obstructions.

6 YH653000290



Operation of this equipment may create sparks that can start fires around dry vegetation. A spark arrestor may be required. The operator should contact local fire agencies for laws or regulations relating to fire prevention requirements.

5 YH653000220

Read and understand your owners manual before operating. If owners manual was not included or you have any questions, please call 1-800-432-ECHO(3246).

Do not operate this equipment in the vicinity of bystanders. Do not allow children to operate this equipment. Obtain and wear safety glasses and use hearing protection at all times when operating this machine. Before inspecting or servicing any part of this machine, shut off power source, disconnect spark plug wire from spark plug and make sure all moving parts have come to a complete stop. Always stand clear of discharge area when operating this machine. Keep face and body away from feed and discharge openings. When feeding shreddable material into chipper, do not allow metal, rocks, bottles, cans or any other foreign material to be fed into chipper or shredder. Before inspecting or servicing any part of this machine, shut off power source, disconnect spark plug wire from spark plug and make sure all moving parts have come to a complete stop.

Check blade bolts for proper torque after every 8 hours of operation. Check blades and rotate or resharpen daily or as required to keep blades sharp. Refer to owners manual for instructions. Failure to do so may cause poor performance, damage or personal injury and will void the machine warranty.

Lower lever slowly to engage chipper. Pull lever up to disengage chipper. Chipper/shredder rotor will continue to rotate when clutch is disengaged. Stop engine and remove spark plug wire before cleaning debris from discharge area or servicing this machine. Do not operate without discharge screen, inlet flaps and all shields in place.

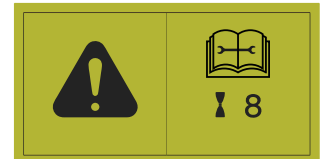
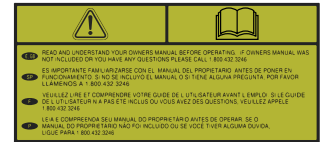

1.7 SAFETY DECAL LOCATIONS

The numbers below correspond to the decals in Section 1.7. Make certain that all safety and operating decals on this machine are kept clean and in good condition. Decals that need replacement must be applied to their original locations.

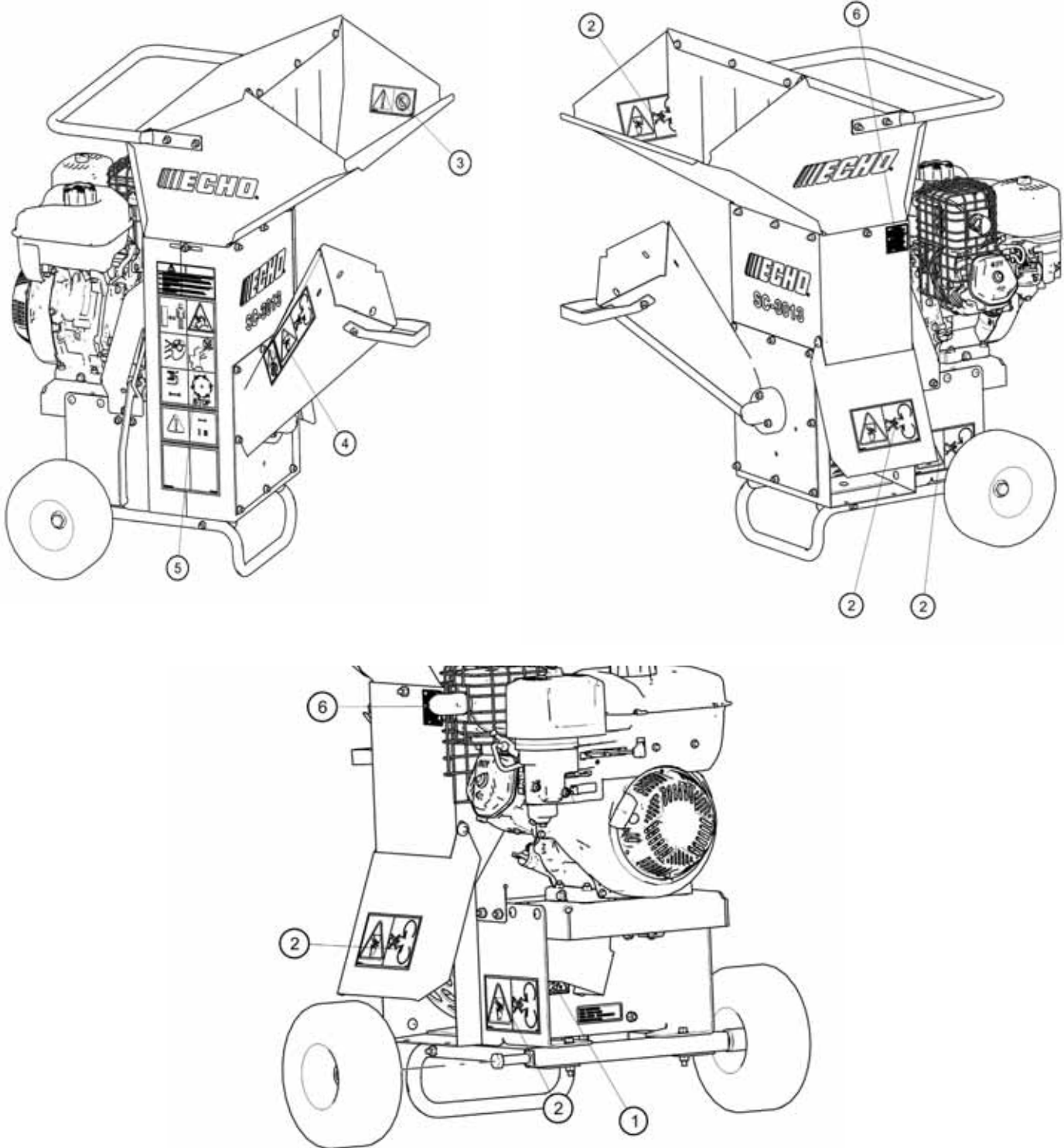

2 ASSEMBLY

Section



WARNING



Do not tip machine onto its side or turn machine upside down during assembly. Machine must be assembled in an upright position.



WARNING



If any bolts or nuts are dropped in the machine, be sure to remove them before starting the machine. Remove items from the shredder area by removing the discharge screen.

2.1 ASSEMBLY

2.1.1 INSTALL LEG STAND, AXLE AND WHEELS

1. Align holes in chipper base (1) with the holes in axle weldment (2) and the support leg (3). Secure assembly to chipper base with two 5/16-18 x 2-1/4" hex head bolts (4) and flange nuts.
2. Secure support leg to the base of the housing body (5) with two 5/16-18 x 1-3/4" hex head bolts (6), and flange nuts.
3. Complete by bolting wheels (7) to axle weldment using two 5/8" x 3" hex head bolts (8).
4. The axle bolts turn into centerlock nuts in the ends of the axle bar and consequently turn fairly hard. Care must be taken not to over tighten the bolts or bearing damage will occur. A properly tightened bolt will allow minimal side to side movement of the wheel while allowing the wheel to spin freely.

2.1.2 ATTACH CHIPPER CHUTE HANDLE

Attach handle (9) to chipper chute (10) using two 5/16" x 3/4" carriage bolts (11) so the head of the bolt is located on the inside of the chute. Install both bolts through handle before fastening with 5/16" flange nuts. This handle is to be attached only to the bottom of part 10.

2.1.3 ATTACH SHREDDER HOPPER HANDLE

To attach handle (12) to shredder hopper (13), install four 5/16" x 1" hex bolts (14) so the head of the bolt is located on the inside of the hopper. Secure bolts with 5/16" flange nuts.

2.1.4 ATTACH SHREDDER HOPPER

1. Install the shredder hopper (13) to the housing body so the handle is located above the engine and the opening is toward the chipper chute.

2. Install eight 5/16-18 x 3/4" carriage bolts (15) so the head of the bolt is located on the inside of the hopper. Fasten bolts with 5/16" flange nuts.

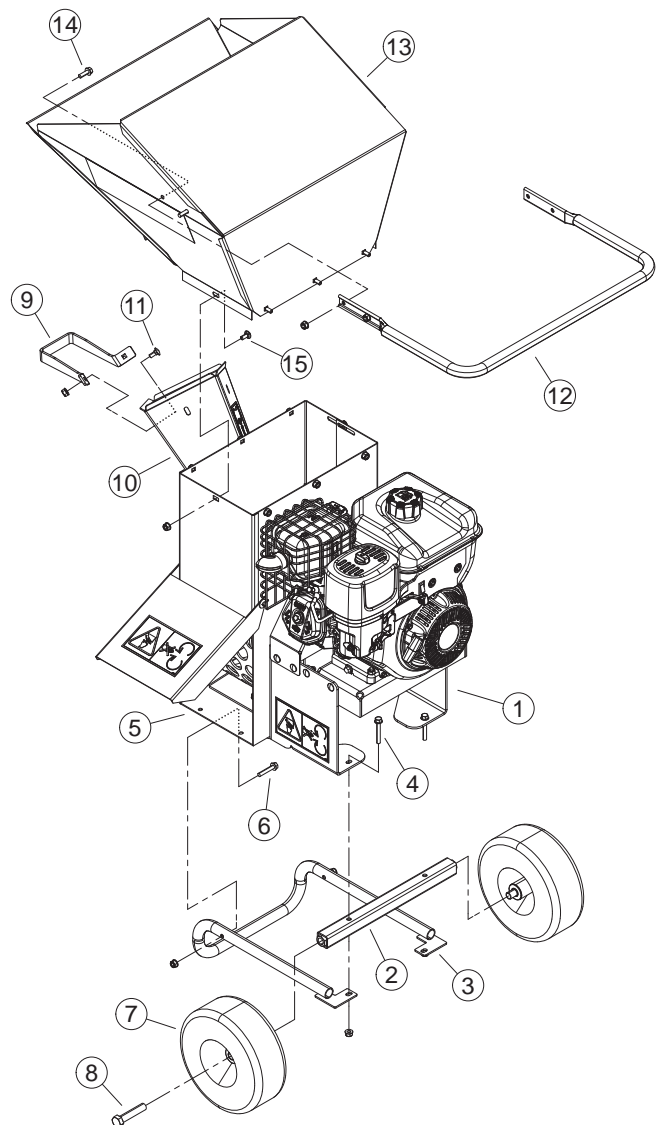

2.2 ADD OIL TO ENGINE

Check the oil level and, if needed, fill the engine crankcase with the type and amount of oil specified in the engine owner's manual.



1. Stop engine, wait for all parts to stop moving and disconnect spark plug wire. Remove key from key switch. Allow the engine and muffler to cool for at least three minutes.
2. Clean area around fuel fill cap and remove cap.
3. Using a clean funnel, fill fuel tank to 1/2" below bottom of filler neck to provide space for any fuel expansion. Install fuel fill cap securely and wipe up any spilled gasoline.

2.3 FILL THE FUEL TANK



WARNING



Gasoline and diesel fuels are highly flammable and their vapors are explosive. To prevent personal injury or property damage:

Store fuel only in approved containers, in well ventilated, unoccupied buildings, away from sparks or flames. A container with a capacity of 2 gallons or less with a pouring spout is recommended. Do

not fill the fuel tank while the engine is hot or running, since spilled fuel could ignite if it comes in contact with hot parts or sparks from ignition. Do not start the engine near spilled fuel. Never use fuel as a cleaning agent.

DO NOT MIX OIL WITH FUEL.

Use only those types of fuels that are recommended in your engine owner's manual.

To add fuel:

3 FEATURES & CONTROLS

Section

Understanding how your machine works will help you achieve the best results when using your chipper/shredder. The following descriptions define the features and controls of your machine.

REFER TO ENGINE OWNER'S MANUAL FOR FURTHER ENGINE OPERATING INSTRUCTIONS.

1. SHREDDER CHUTE

Materials no larger than 3/4" (1.9 cm) in diameter are fed through the shredder chute to the shredder knives.

2. CHIPPER CHUTE

Materials no larger than 3" (7.6 cm) to be chipped are fed through the chipper chute to the chipper blades.

3. ENGINE THROTTLE

This controls the speed of the engine. Increase the throttle by moving the lever to the FAST position. To decrease the throttle, move the lever to the SLOW position.

4. ENGAGEMENT HANDLE

During engine start-up, the engagement handle must be in the disengaged (UP) position. With the engine at 1/4 throttle, carefully engage the rotor by slowly pushing the engagement handle down, allowing the rotor to speed up gradually. Engaging the chipper too quickly with the engine at full or half throttle will bog down the engine and will shorten the life of the belt. See Sections 4.2 and 4.4.

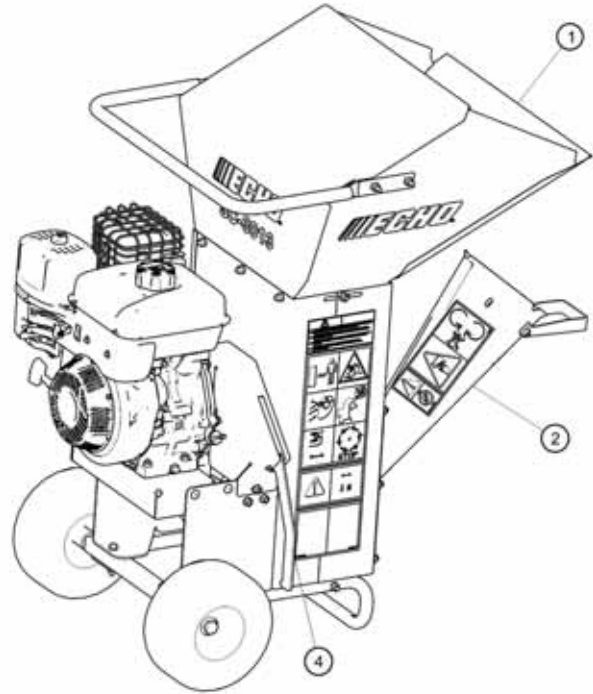

Figure 3.1, Start Position Belt Disengaged



Figure 3.2, Operating Position Belt Engaged

5. ENGINE CHOKE

Use when starting a cold engine. Move lever to the choke position when starting. Move lever to the run position when engine is running. Refer to engine manual for further engine operating instructions.

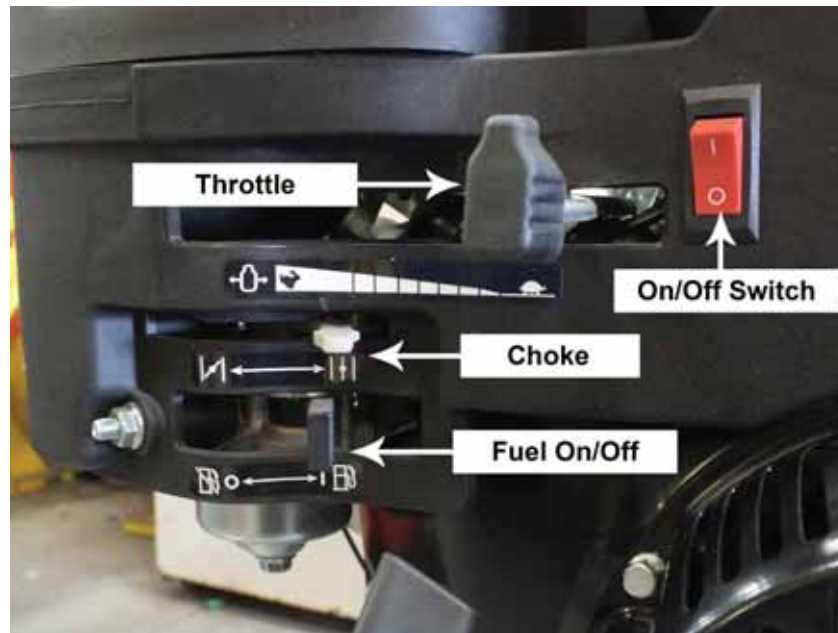

Figure 3.3

4 OPERATION

Section

As with any other piece of outdoor equipment, getting the feel for how your machine operates and getting to know the best techniques for particular jobs are important to overall good performance.

CHIPPING OPERATION

The chipping operation takes place on the front of the machine, where hardened steel chipper blades are mounted on a rotating rotor assembly. Material fed into the chipper chute is sliced into small chips and propelled out through a discharge tube.

SHREDDING OPERATION

In this operation, hardened steel shredder knives grind up material fed into the shredder chute. The shredded material then leaves the shredder area by traveling through the discharge screen. The shredded material can be diverted into a container or onto the ground.



WARNING



Move machine to a clear, level area outdoors before starting. Do not operate in the vicinity of bystanders. Make sure cutting chamber is empty before starting.



WARNING



Before operating your machine, be sure you read and understand all safety, controls and operating instructions in this owner's manual and on your machine. Failure to follow these instructions can result in serious injury or property damage.

NOTE

FOR THE SPECIFIC STARTING, OPERATING AND SERVICE INFORMATION PERTAINING TO YOUR EXACT ENGINE MODEL, ALWAYS CONSULT THE ENGINE OWNER'S MANUAL FIRST.

4.1 STARTING ENGINE

BEFORE ATTEMPTING TO START THIS MACHINE, MAKE SURE THE BELT IS DISENGAGED AND THE HANDLE IS IN THE "START" POSITION.

NEVER ATTEMPT TO START MACHINE WITH THE DRIVE BELT ENGAGED.

1. Check engine oil level before starting.
 2. Place the throttle control midway between the SLOW and FAST positions. Place the choke control into the CHOKE position.
 3. Place the chipper engagement lever in the START position.
 4. Use key switch/recoil to start the engine.
 5. Move the clutch to the RUN position.
- **For a cold engine:** gradually return the choke to the OFF position after the engine starts and warms up.
 - **For a warm engine:** use of choke may not be necessary for restart of a warm engine. If it is needed, return choke to the OFF position once the engine starts.

4.2 OPERATING THE CHIPPER

After the engine has been started and properly allowed to warm to an operating temperature, you can begin operating the chipper. To properly start and operate the chipper, follow the steps below:

1. **AFTER** engine is warmed and ready for use, move the throttle control back to approximately 25% of full throttle.
2. When engine is running at approximately 25% of full throttle, **SLOWLY** engage belt by using the belt engagement lever.

DO NOT engage the belt with engine running at high RPM.

Engaging belt while engine is running at high RPM will result in significant belt squealing and damage.

Engaging belt while engine is running at high RPM can also damage vital drive components of the chipper.

3. If the chipper engine stalls while engaging the belt, return the engagement handle back to the START position, restart engine, **SLIGHTLY** increase throttle and attempt engagement again.
4. Once the belt is engaged, **SLOWLY** increase throttle to 100% or full throttle.
5. **ALWAYS** run the chipper at 100% or full throttle when chipping material.

4.3 CHIPPER OPERATION GUIDELINES



WARNING



Read and follow all safety instructions in this manual. Failure to operate the machine in accordance with the safety instructions **MAY RESULT IN PERSONAL INJURY!**

The machine chips a variety of materials into a more readily decomposed or handled condition. The following guidelines will help you get started.

1. **Gradually increase engine speed until full throttle is achieved.**
2. **ALWAYS** run engine at full operating speed before starting to chip material.
3. **If the chipper rotor slows**, stop feeding material. Allow the rotor to process backed up material. Feed material more evenly.
4. **If the chipper jams**, remove the branch and rotate it before reinserting into the chute. Alternately insert and retract the limb or insert continuously at a rate that will not kill the engine.
5. **Sharpen the chipping blades periodically.** Check the sharpness of the blades every 5-15 hours. Refer to the Service and Maintenance section for sharpening instructions.
6. **Limbs fed in to the chipper chute must be 3" (7.6 cm) in diameter or less.** Trim side branches that cannot be bent enough to feed into the chipper chute. Hold small diameter branches together in a bundle and feed in simultaneously.
7. **Material fed into the shredder chute must be 3/4" (1.9 cm) in diameter or less.** Common shredding materials include grass, leaves, garden refuse, sticks, and small branches.



WARNING



DO NOT INSERT BRANCHES LARGER THAN 3/4" INTO SHREDDER OR MACHINE DAMAGE MAY OCCUR.

8. **Alternate green or fresh cut material with dry material to lubricate the chipping blades for longer life and better performance.** Chipping dead, dry material will create heat and dull the chipping blades quicker.
9. **ALWAYS feed brush from the side of the chipper chute**, rather than from the front. Step aside to avoid being hit by the brush moving into the chipper.
10. **ALWAYS place limb, butt end first, into the chipper chute until it contacts the chipper blades.** The actual feed rate of the limb into the chipper will depend on the type of material fed and sharpness of the cutting blades.
11. **NEVER use the belt engagement to clear a plugged rotor.** This may cause belt damage. Refer to the instructions for clearing a plugged rotor in the Service and Maintenance section.
12. **NEVER** attempt to clear a plugged rotor or discharge with the engine running. **ALWAYS** shut engine OFF and remove the spark plug wire before servicing any part of this machine.
13. **NEVER** attempt to chip pieces of metal, rock, bottles, cans or other foreign objects.



CAUTION



- **Never** lean over the chipper chute to push objects into the cutting device. Use a push stick or brush paddle.
- **Never** use shovels or forks to feed brush. They can cause extensive damage if they contact the blades. In addition, metal pieces can be ejected from the chipper chute and cause serious injury or death.
- **Never** feed brush into the chute with your feet.
- **Never** use hands or feet to clear materials that build up in the chute.



CAUTION



- Obtain and wear safety glasses at all times when operating the machine.
- Do not wear loose fitting clothing.
- The operator should always wear heavy boots, gloves, pants and a long-sleeved shirt.
- Use common sense and practice safety to protect yourself from branches, sharp objects, and other harmful objects.

4.4 SLOWING AND STOPPING THE CHIPPER ROTOR AND ENGINE

NEVER disengage the belt as part of the stopping or shut down process. The belt should remain engaged during the entire shutdown process.

Leaving the belt engaged is a vital part of proper shutdown and ensures the rotor stops spinning in conjunction with the engine shutting off.

TO PROPERLY SLOW DOWN AND STOP THE ROTOR AND ENGINE

1. With the belt still engaged, slowly move the throttle to the SLOW position.
2. Allow the engine to run at slow idle for 30-60 seconds.
3. Stop the engine by moving the throttle to the STOP position or turning off the ignition switch.
4. Allow rotor to come to a complete stop.
5. Once the engine is off and the rotor has completely stopped, the belt can be disengaged by moving the belt engagement handle back to the START position.

NOTE

The rotor will continue to turn for some time after the engine has been shut off. Make sure rotor has stopped completely before inspecting or servicing machine.

5 SERVICE & MAINTENANCE

Section

5.1 MAINTENANCE SCHEDULE

The items listed in this service and maintenance schedule are to be checked, and if necessary, corrective action taken. This schedule is designed for units operating under normal conditions. If the unit is operating in adverse or severe conditions, it may be necessary for the items to be checked and serviced more frequently.

SEE ENGINE OWNER'S MANUAL FOR FURTHER ENGINE MAINTENANCE AND TROUBLESHOOTING INFORMATION.



WARNING



To prevent personal injury or property damage: shut off engine and make sure that all moving parts have come to a complete stop before, servicing, adjusting or repairing. Disconnect the battery and remove ignition key where applicable.

SERVICE AND MAINTENANCE SCHEDULE							
COMPONENT	MAINTENANCE REQUIRED	REFER TO ENGINE OPERATOR'S MANUAL	FREQUENCY				
			BEFORE EACH USE	EVERY 8 HOURS	EVERY 25 HOURS	EVERY 50 HOURS	EVERY YEAR
Engine oil	Change (1)	•					
Fuel filter	Replace	•					
Spark plug	Check condition and gap	•					
Engine oil	Check/fill		•				
Fuel tank	Check/fill		•				
All internal and external nuts and bolts	Check tightness		•				
Chipper blades	Check sharpness and re-torque to 25 ft-lbs. (2)			•			
Shredder knives	Check condition			•			
Spark arrestor*	Clean			•			
Entire machine	Clean			•			
Drive belt	Check				•		
Belt tension	Check				•		
Belt/pulley alignment	Check				•		
Grease zerks	Lube					•	
Wheel bearings	Check						•
(1) Perform more frequently under extremely dusty conditions.							
(2) Perform more frequently when chipping dry or dirty wood.							
*If equipped							
As the Limited Warranty states, failure by the Owner to perform normal maintenance will void the machine's warranty. The aggressive, high-speed nature of chipping REQUIRES THE OWNER TO PERFORM THE ABOVE LISTED NORMAL MAINTENANCE. Special consideration to maintain and re-torque the CHIPPER ANVIL, CHIPPER BLADES, and ALL INTERNAL AND EXTERNAL NUTS AND BOLTS is the sole responsibility of the Owner. Failure by the Owner to do so shall be cause for denial of warranty.							



WARNING



BEFORE INSPECTING OR SERVICING ANY PART OF THIS MACHINE, SHUT OFF POWER SOURCE, AND MAKE SURE ALL MOVING PARTS HAVE COME TO A COMPLETE STOP.

5.2 ROTOR LOCK

There are holes on the rotor that are utilized to lock the rotor in place before performing any kind of service and/or maintenance.

Follow the steps below to lock the rotor:

1. Insert bolt into hole on the chute side housing panel and through holes on rotor to prevent the rotor from turning.
2. Remove bolt when service and/or maintenance is completed.

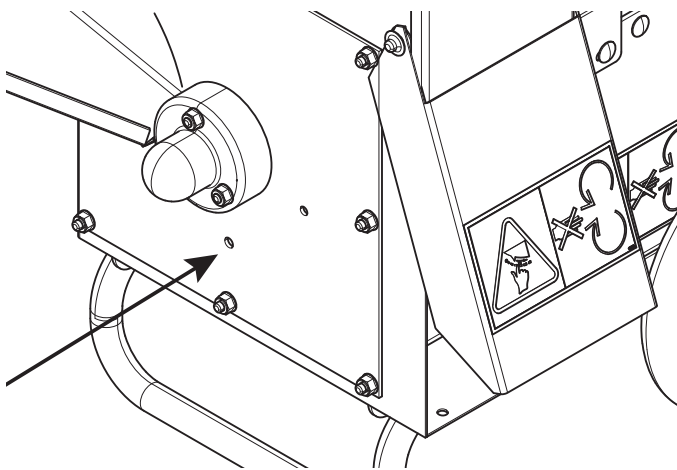
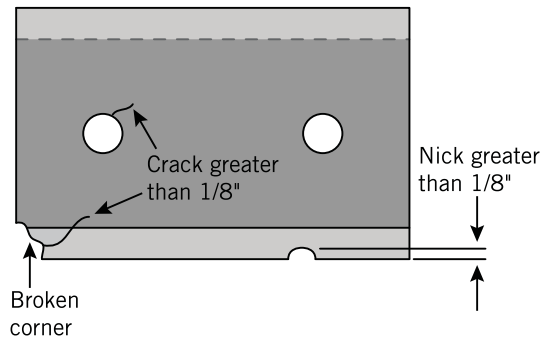
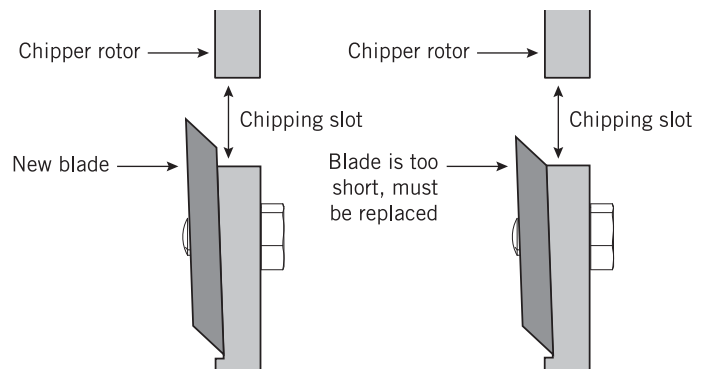

Figure 5.1, Rotor Lock Hole

- There are cracks, broken corners or nicks greater than 1/8" (see below).



- The base of the cutting edge is worn or has been re-sharpened so that it no longer extends past the chipping slot (see below).



5.3 CHIPPER BLADES MAINTENANCE

The chipper blades will eventually become dull, making chipping difficult and adding extra strain on the machine. **CHECK THE SHARPNESS OF THE BLADES EVERY 5-15 HOURS OF OPERATION AND SHARPEN AS NEEDED.**

Your blades need to be sharpened if:

- Machine vibrates severely when material is fed into the chipper.
- Chips discharge unevenly or have stringy tails, especially when chipping green branches.

Before you sharpen the chipping blades, check for permanent damage. Replace the blade if:

5.4 REMOVING THE BLADES



WARNING



Chipping blades are sharp! Use caution when working on machine to avoid injury.

1. Install the rotor lock (see Section 5.2).
2. Flip the discharge door/shield (1) up.
3. Remove the 5/16" x 7/8" carriage bolt (2) and flange nut (3) holding the shredder screen (4) to the bottom of the frame. Pull discharge screen out from the bottom and rotate the top downward to remove.
4. Remove the two bolts that hold the blade to the rotor. The hardware can be reused. Repeat for the remaining blade.
5. The blades have two edges and can be reversed one time before sharpening.

⚠ WARNING ⚠

BEFORE INSPECTING OR SERVICING ANY PART OF THIS MACHINE, SHUT OFF POWER SOURCE, AND MAKE SURE ALL MOVING PARTS HAVE COME TO A COMPLETE STOP.

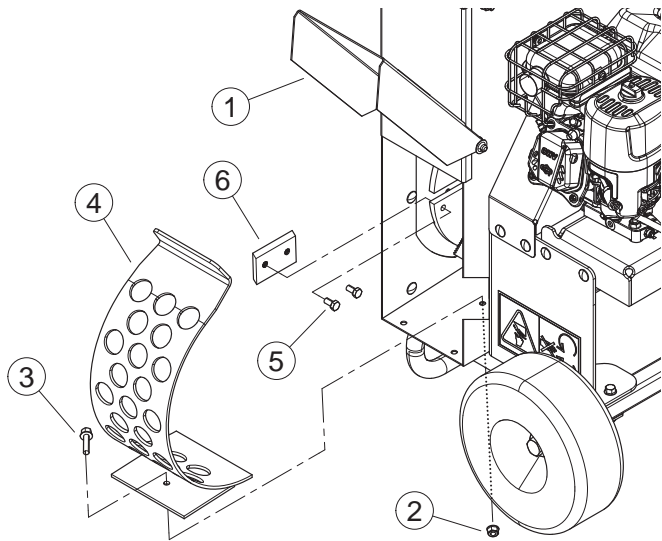

Figure 5.2, Blade Removal and Installation
*Model Shown SC-2013

3. Be careful when grinding so that the blade does not become overheated and change color. This will remove the heat-treated properties.
4. Use short grinding times and cool with water or some type of liquid coolant.
5. Remove an equal amount off each blade to maintain rotor balance.
6. Small imperfections such as nicks and burrs on the flat side of the blade will not affect the chipping performance of the machine.
7. For blades that have been repeatedly sharpened, ensure that the sharpened surface extends past the chipping slot opening. If it does not extend past the opening, the blades should be replaced (see Section 5.3).

5.5 SHARPENING THE BLADES

The blades can be ground on a bench grinder or by a professional.

1. Never sharpen or grind the mounting surfaces of the blades. This will cause the edge to roll and the blade will be damaged, resulting in poor chipping performance.
2. Regrind the angled edge of the chopping blades to 45 degrees (Figure 5.3). Use the blade angle gauge plate when sharpening the blades to achieve the proper angle (see Figure 5.4).

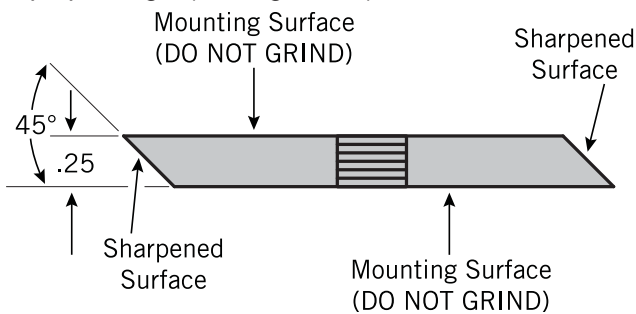

Figure 5.3, Chipper Blade Surfaces

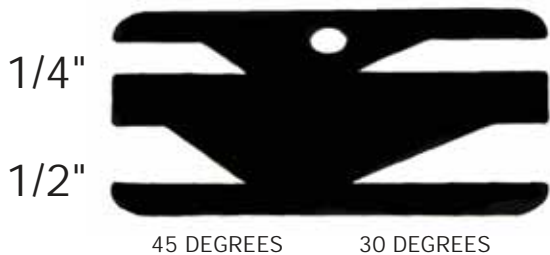

Figure 5.4, Blade Angle Gauge Plate

5.6 INSTALLING THE BLADES

See Figure 5.2 for illustration.

1. Clean away any material that may be between the blade and mounting surface on the rotor.
2. Place a blade (6) on the rotor and attach with two 5/16-18 x 5/8" bolts (5). Torque to 25 ft-lb. Repeat for the second blade.
3. Reinstall the shredder screen (4) in the machine with

NOTE

Make sure the top flange of the discharge screen is properly and completely installed into upper slot of the housing. Failing to do so may cause knives to make contact with discharge screen during operation.

- 5/16" x 1" bolt (2) and flange nut (3).
4. Lower the discharge door/shield (1) into the normal operating position.
5. Remove rotor lock.



WARNING



BEFORE INSPECTING OR SERVICING ANY PART OF THIS MACHINE, SHUT OFF POWER SOURCE, AND MAKE SURE ALL MOVING PARTS HAVE COME TO A COMPLETE STOP.

5.7 SHREDDER KNIVES MAINTENANCE

Do not attempt to sharpen shredder knives. Inspect the knives often for signs of damage.

If a knife has any sign of cracking or is broken in any way, it should be replaced immediately.

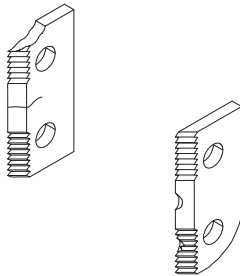

Figure 5.5, Examples of Damage to Knives

5.8 REMOVING THE SHREDDER KNIVES



WARNING



The serrated edge of the shredder knives should face the same direction as the cutting edge of the chipper blades. Never reuse the #10-24 nut and bolt. Never reuse shafts or spacers if they show signs of wear or abuse. Always install new parts when repairing.

1. Remove the lower belt guard from under engine frame, remove discharge door/shield and discharge screen.
2. Remove the 10-24 x 1-3/8" bolts and nuts from knife shafts.
3. Align shaft with the 5/8" hole in rear of frame and the small hole in front of frame by the chipper chute.
4. Using a small punch or rod, push the shaft out the 5/8" hole in rear of frame.
5. To assemble, insert shaft through the 5/8" hole in rear of frame and slide knives and spacers in their proper order onto the shaft. **Install a new 10-24 x 1-3/8" bolt and nut.**
6. Repeat steps 3 through 6 to assemble the other three shafts.
7. When completed, install the discharge screen, discharge door shield and torque all 3/8" bolts to 33 ft-lbs. Test run machine.

5.9 ADJUSTING THE CHIPPER ANVIL

The chipping blades should clear the anvil by 1/16" to no greater than 1/8". Check the clearance every 8 hours of operation and adjust if needed.

To adjust the anvil:

1. Remove the rotor shaft end cap and lower belt shield.
2. Loosen the set screws (1) holding the lock collars (2) on the chute side (Figure 5.6) and engine side (Figure 5.7) bearings.
3. Use a punch and hammer in punch hole (3) to tap the lock collars in the opposite direction of normal rotation.

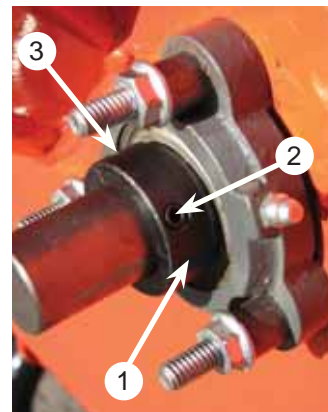

Figure 5.6, Chute Side Bearing

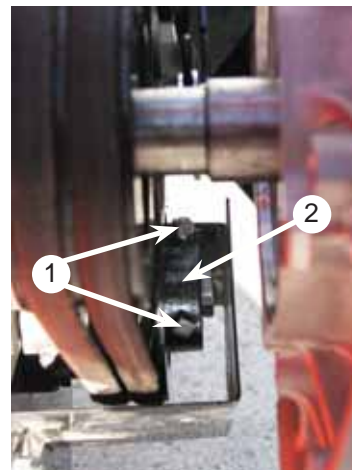

Figure 5.7, Engine Side Bearing

NOTE

On the chute side bearing, tap punch in a CW rotation. On the engine side bearing, tap punch in a CCW rotation.

**WARNING**

BEFORE INSPECTING OR SERVICING ANY PART OF THIS MACHINE, SHUT OFF POWER SOURCE, AND MAKE SURE ALL MOVING PARTS HAVE COME TO A COMPLETE STOP.

4. Using a rubber mallet tap the end of the rotor shaft to obtain 1/16" to no greater than 1/8" clearance. Rotate the rotor and check the clearance on all chipping blades.
5. Once clearance has been set, the lock collars must be replaced and retightened. Using a punch and a hammer, tap the lock collars in the direction of shaft rotation (**clockwise on the engine side bearing and counterclockwise on the chute side bearing**) and set them with a hammer tap. Tighten the lock collar set screws.
6. Loosen the set screws holding the belt pulley on the rotor shaft. Move the pulley on the shaft so it is aligned with the engine drive pulley. The pulley should be moved the same amount the rotor was moved, only in the opposite direction. Torque pulley set screw to 160 in-lbs.
7. Insure the pulley drive key is completely seated under the pulley and tighten the set screws.
8. Check pulley alignment by laying a straightedge across the pulley faces. Pulley faces should line up. If not, repeat steps 6 and 7 until the pulley is lined up.

5.10 CLEARING A PLUGGED ROTOR

Feeding too large or too much material at once may plug the chipper. To clear a plugged rotor, proceed as follows:

1. Shut off engine and allow all moving parts to come to a complete stop.
2. Remove the 5/16" × 7/8" carriage bolt and flange nut securing the discharge screen to the frame and remove the shredder screen.
3. Clean the debris away from the chipper rotor. Turn the rotor by hand to be sure it is free to rotate. Be careful to avoid the chipper blades when cleaning out the debris.
4. Install discharge screen and retaining hardware.

5.11 CHANGING THE DISCHARGE SCREEN

There are several optional discharge screens available in different sizes (see Section 8). Optional discharge screens produce different sized chips. To change the discharge screen, proceed as follows:

1. Shut machine off, make sure all moving parts have completely stopped and disconnect spark plug wire.
2. Lift discharge door/shield to gain access to the discharge screen.
3. Remove the 5/16" × 7/8" carriage bolt (1) and flange nut (2) securing the discharge screen to the frame (Figure 5.8). Pull discharge screen out from the bottom and rotate the top downward to remove.
4. Clean any trash or debris out from the screen area.
5. Insert the top of the replacement screen into the slot in the chipper body and push the bottom of the screen inward so bolt holes align.
6. Install the bolt through the screen and down through the frame, attach flange nut and tighten securely.

NOTE

Make sure the top flange of the discharge screen is properly and completely installed into upper slot of the housing. Failing to do so may cause knives to make contact with discharge screen during operation.

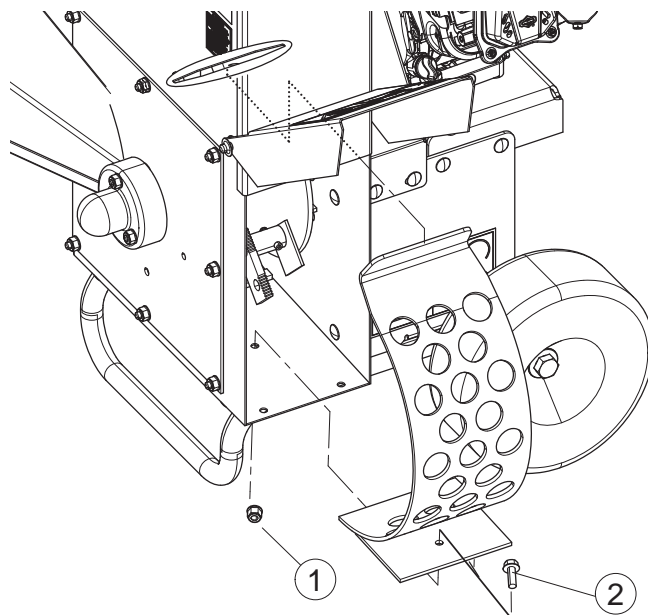

Figure 5.8, Changing the Discharge Screen

*Model Shown SC-2013



WARNING



BEFORE INSPECTING OR SERVICING ANY PART OF THIS MACHINE, SHUT OFF POWER SOURCE, AND MAKE SURE ALL MOVING PARTS HAVE COME TO A COMPLETE STOP.

5.12 BELT GUIDE ADJUSTMENTS

The belt guide aids in disengaging the chipper/shredder. If problems arise with engaging and disengaging the unit, follow the instructions below. These instructions also adjust the lower belt guard.

1. Remove belt shield to expose the belt and pulleys.



Figure 5.9, Belt Shield Removal

2. Loosen set screws and using a straightedge align the engine pulley (1) with the idler pulley (2) and the rotor pulley (4) with the engine pulley (1). See Figure 5.11. Tighten all set screws.



Figure 5.10, Engine Side Bearing Set Screws

3. Engage the clutch with the belt (3) in place and check idler engagement. See Figure 5.11. The idler pulley should impact the belt in the center of the pulley. All pulleys must be in perfect alignment. Torque pulley set screws to 160 In-lbs.
4. If idler pulley will not remain in alignment with engine and rotor pulleys, it may be necessary to replace the idler bracket bushings.
5. There should be 1/8" clearance between the belt and the upper belt guard when the clutch is engaged. Adjust by loosening the mounting bolts and repositioning the guide. Retighten mounting bolts.
6. Reinstall upper shield.
7. From underneath, check the alignment of lower belt guard with a post card. With the clutch engaged, there should be enough room between the belt and the side of the guard for the card to slide along the belt. With the clutch disengaged, the card should not be able to slide. Adjust if necessary.

**WARNING**

BEFORE INSPECTING OR SERVICING ANY PART OF THIS MACHINE, SHUT OFF POWER SOURCE,
AND MAKE SURE ALL MOVING PARTS HAVE COME TO A COMPLETE STOP.

5.13 DRIVE BELTS

Check the condition of the drive belt annually or after every 25 hours of operating, whichever comes first. If the belt is cracked, frayed, or worn, replace it. To replace or adjust drive belt, proceed as follows:

1. Remove the belt shield, upper belt guide (6) and lower belt guard (5).
2. Remove idler pulley (2).
3. Slip the drive belt off the belt pulleys.
4. Inspect pulleys for wear. Replace the pulleys if they are cracked or worn so that the belt contact area is not smooth and flat.
5. Place the new belt over pulleys. Do not force or pry the belt over pulleys as this may cause cord breakage.
6. Reinstall the idler pulley, ensuring that the belt is on the outside edge of the idler pulley.
7. Check all pulleys to make sure they are properly aligned.
8. Replace all shields, guides and guards.

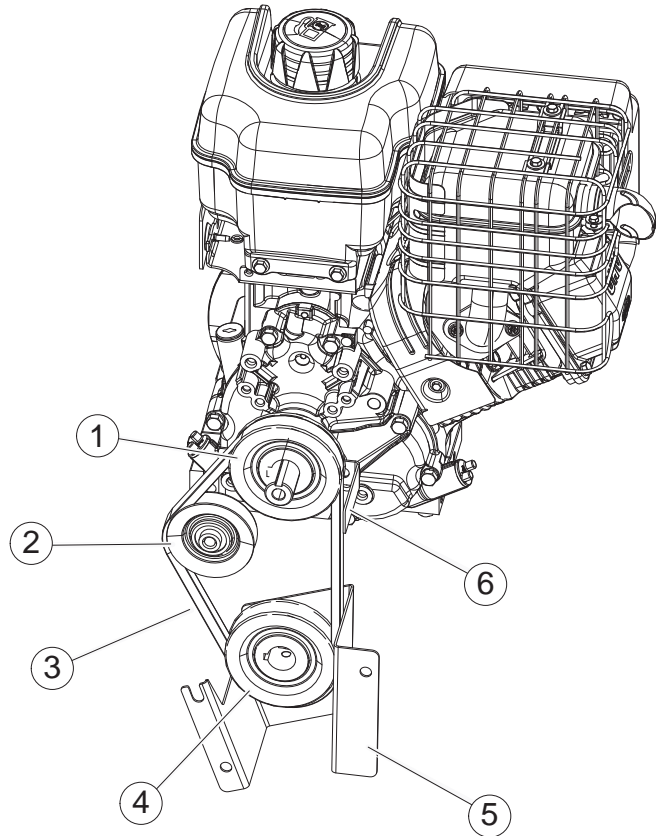

Figure 5.11

5.14 REMOVING THE ROTOR

1. Remove discharge door/shield, discharge screen and rotor shaft end cap on chute side of the machine.
2. Loosen the set screws on the lock collar securing the chute side bearing on the rotor shaft.
3. Using a punch and hammer, tap the lock collar in the opposite direction of normal rotation until loose; remove lock collar and bearing.
4. Remove the upper shield, upper belt guide and lower belt guard to allow access to the engine side bearing.
5. Remove the drive belt.
6. Loosen the set screws holding the belt pulley on the rotor shaft and remove the pulley.
7. Repeat steps 2 and 3 on the engine side rotor bearing.
8. Remove the bolts securing the chipper chute cover to the frame and remove chipper chute cover.
9. Remove rotor.



WARNING



BEFORE INSPECTING OR SERVICING ANY PART OF THIS MACHINE, SHUT OFF POWER SOURCE, AND MAKE SURE ALL MOVING PARTS HAVE COME TO A COMPLETE STOP.

5.15 CHANGE OIL

Check the oil level before each use. Change oil as directed in the engine owner's manual.

5.16 LUBRICATION



WARNING



Polyurea and lithium-based greases are not compatible. Mixing the two grease types may lead to premature failure.

Lubricate the machine periodically with a lithium-based grease. Extreme working conditions will require more frequent greasing.

Grease the following points every 50-100 hours of operating time:

- Engine side bearing
- Chute side bearing

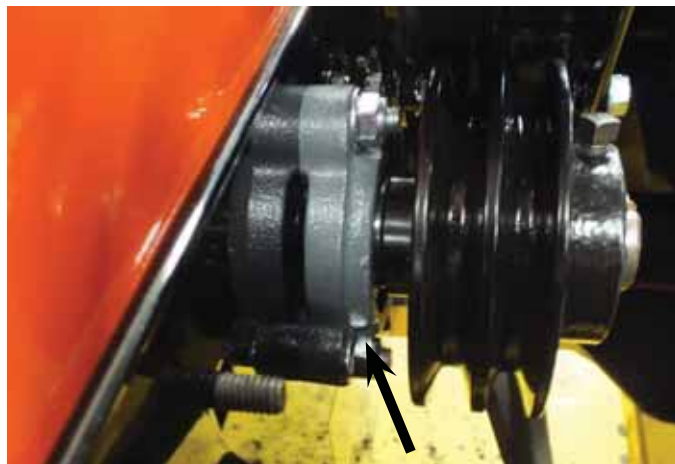

Figure 5.12, Engine Side Bearing Zerk (Bottom of Bearing)

NOTE

Do not over grease bearings. Overfilling can lead to excessive heat and/or unseating of the seals. Add grease slowly and under light pressure. Whenever possible, rotate bearing slowly while lubricating.



Figure 5.13, Chute Side Bearing Zerk

6 TROUBLESHOOTING

Section

Before performing any of the corrections in this troubleshooting chart, refer to the appropriate information contained in this manual for the correct safety precautions and operating or maintenance procedures. Contact your dealer or ECHO for service problems with the machine.

PROBLEM	POSSIBLE CAUSES	REMEDY
Engine will not start	Lack of fuel or oil	Fill fuel tank and check oil level
	Spark plug disconnected	Connect spark plug
	Kill switch on access cover is damaged	Test kill switch. Replace if it is not working
	Dirty, stale, or contaminated fuel	Drain and refill fuel tank with fresh, clean unleaded regular gasoline or diesel. Replace fuel filter.
	Internal engine problems	See your engine dealer
Engine or rotor stalls or stops	Chipper rotor housing or discharge tube is plugged	Shut off engine and disengage belt engagement. Refer to manual for information on clearing a plugged rotor. Never use the belt engagement to clear a plugged rotor.
	Feeding material that is too large	Limit branch size to rated capacity
Engine overheats	Cooling system plugged	Clean cooling fan and cooling fins on the radiator or engine block
	Improper coolant level	Fill engine to correct coolant level. Refer to the engine owner's manual
Engine stalls or belt squeals when engaging belt	Engaging belt too fast	Reduce engagement speed
	Belt tension too loose	Adjust tensioner. Replace belt if needed.
Engine runs, but dies or does not accelerate properly	Air filter dirty	Clean or replace
	Fuel filter dirty	Replace
	Fuel vent plugged	Clean or replace
	Spark plug dirty/worn	Clean and adjust or replace
	Carburetor vibration	Adjust
	Cooling system dirty/plugged	Clean
	Spark arrestor* plugged	Clean or replace
Machine chips poorly	Dull chipper blades	Flip, sharpen, or replace
	Drive belts loose or worn	Inspect drive belts, adjust or replace if needed
	Feeding material that is too large	Limit branch size to rated capacity

*If equipped

TROUBLESHOOTING

PROBLEM	POSSIBLE CAUSES	REMEDY
Cannot engage belt	Improper belt installation, belt not under belt guide	Install belt properly, install belt under belt guide
	Improper belt tension	Adjust belt tension, Replace belt or belt tension spring if needed
Excessive belt wear	Not using correct belt	Contact your nearest authorized dealer to order the correct belt for your chipper
	Pulley(s) damaged or worn	Replace pulley(s)
	Pulley(s) not in alignment	Align pulley(s) to within 1/16" with straight edge
	Belt(s) tension too loose	Replace belt or belt tension spring
Hard to feed chipper, requires excessive power to chip	Dull chipper blades	Flip, sharpen, or replace
	Obstructed discharge	Use branch or similar object to clear discharge tube
	Improper blade clearance	Set blade/anvil clearance to recommended distance
Excessive vibration while running	Dull chipper blades	Flip, sharpen, or replace
	Drive system vibration	Check drive belts, bearings, and pulleys for bad or worn areas. Check for dull chipper blades.
	Rotor out of balance	Inspect rotor for damaged or missing chipper blades, replace if needed
	Chipper blade to anvil clearance is incorrect	Set blade/anvil clearance to recommended distance

7 SPECIFICATIONS

Section

DESCRIPTION	ENGLISH	METRIC
Machine Dimensions (LxWxH)	44" x 25" x 46"	112 cm x 64 cm x 117 cm
Weight	233 lbs.	106 kg
Maximum Chipper Capacity	3" diameter	7.6 cm diameter
Chipper Blades	2 reversible (3.125" x 2" x 0.25")	2 reversible (7.9 cm x 5.1 cm x 0.64 cm)
Maximum Shredder Capacity	0.75"	1.9 cm
Shredder Knives	12	
Rotor Speed	3600 RPM	
Rotor Size	11" diameter	27.9 cm diameter
Rotor Weight	27 lbs.	12.3 kg
Drive Type	Belt	
Tires	410/350 4" (foam-filled)	410/350 10.2 cm (foam-filled)
Engine	Briggs & Stratton® XR Professional Series™ 306cc	
Fuel Tank Capacity	3.2 quarts (0.8 gallons)	
Starter	Recoil	
Spark Arrester Equipped*	No	



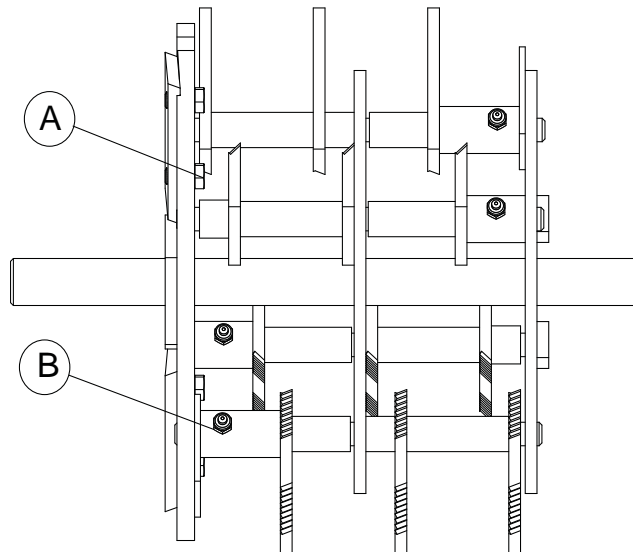

* - If a spark arrester is required it must meet the specifications and performance requirements of local, state, and federal laws and regulations. A spark arrester is available from authorized servicing dealers.

SPECIAL TORQUE REQUIREMENTS			
LOCATION	HARDWARE DESCRIPTION	TORQUE (UNIFIED INCH)	TORQUE (METRIC)
A – On rotor plate, blade mounting bolts	5/16 x 1" hex HD, grade 8 bolts	25 ft-lbs.	34 Nm
B – On rotor knife shafts	10-24 x 1-1/8" screw	36 in-lbs.	4 Nm



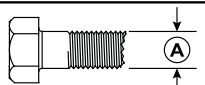



7.1 BOLT TORQUE

The tables below are for reference purposes only and their use by anyone is entirely voluntary, unless otherwise noted. Reliance on their content for any purpose is at the sole risk of that person and any loss or damage resulting from the use of this information is the responsibility of that person.

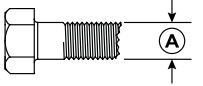
SAE Grade and Head Markings	SAE 2	SAE 5	SAE 8	Bolt Diameter 
				

BOLT DIAMETER (A)	BOLT TORQUE*					
	SAE 2		SAE 5		SAE 8	
	NM	FT-LB.	NM	FT-LB.	NM	FT-LB.
1/4"	7.5	5.5	11	8	16	12
5/16"	15	11	23	17	34	25
3/8"	27	20	41	30	61	45
7/16"	41	30	68	50	95	70
1/2"	68	50	102	75	149	110
9/16"	97	70	149	110	203	150
5/8"	122	90	203	150	312	230
3/4"	217	160	353	260	515	380
7/8"	230	170	542	400	814	600
1"	298	220	786	580	1220	900
1-1/8"	407	300	1085	800	1736	1280
1-1/4"	570	420	2631	1940	2468	1820

Metric Grade and Head Markings	4.8	8.8	10.9	12.9	Bolt Diameter 
					

BOLT DIAMETER (A)	BOLT TORQUE*							
	4.8		8.8		10.9		12.9	
	NM	FT-LB.	NM	FT-LB.	NM	FT-LB.	NM	FT-LB.
M3	0.5	0.4	–	–	–	–	–	–
M4	3	2.2	–	–	–	–	–	–
M5	5	4	–	–	–	–	–	–
M6	6	4.5	11	8.5	17	12	19	14.5
M8	15	11	28	20	40	30	47	35
M10	29	21	55	40	80	60	95	70
M12	50	37	95	70	140	105	165	120
M14	80	60	150	110	225	165	260	190
M16	125	92	240	175	350	255	400	300
M18	175	125	330	250	475	350	560	410
M20	240	180	475	350	675	500	800	580
M22	330	250	650	475	925	675	1075	800
M24	425	310	825	600	1150	850	1350	1000
M27	625	450	1200	875	1700	1250	2000	1500

*Torque value for bolts and capscrews are identified by their head markings.

Torque figures indicated above are valid for non-greased or non-oiled threads and heads unless otherwise specified. Therefore, do not grease or oil bolts or capscrews unless otherwise specified in this manual. When using locking elements, increase torque values by 5%.

8 OPTIONS

Section

PART NUMBER	DESCRIPTION
99944300000	SCREEN, FINE DISCHARGE (3/8" DIAMETER HOLES)
99944300001	SCREEN, MEDIUM DISCHARGE (3/4" DIAMETER HOLES)
99944300002	SCREEN, COARSE DISCHARGE (1-3/8" DIAMETER SLOTS)
99944300003	SCREEN, WET DEBRIS
99944300008	ALL WEATHER COVER
99944300009	LEAF TAMPER
99944300010	KIT, TWO WHEEL TOW
99944300011	KIT, 3" DISCHARGE DEBRIS BAG
99944300012	BLOWER WITH 2-BLADE RADIAL FAN
99944300013	KIT, CHIPPER BLADE
99944300014	KIT, SHREDDER KNIVES



Discharge Debris Bag, 99944300011

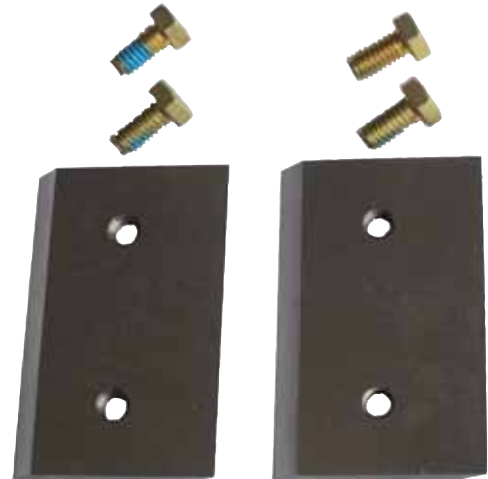

Chipping Blade Kit, 99944300013

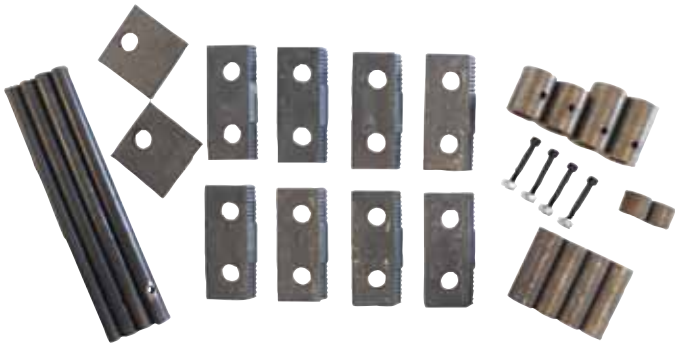

Shredder Knife Kit, 99944300014



Leaf Tamper, 99944300009



All Weather Cover, 99944300008



Discharge Screens.
See Chart for Part Number Details.



Two Wheel Tow Kit, 99944300010

9

Section

PRODUCT REGISTRATION

PRODUCT REGISTRATION

Thank you for choosing ECHO Power Equipment

Please go to <http://www.echo-usa.com/Warranty/Register-Your-ECHO> to register your new product on-line. It's FAST and EASY! NOTE: your information will never be sold or misused by ECHO, Inc. Registering your purchase enables us to contact you in the unlikely event of a service update or product recall, and verifies your ownership for warranty consideration.

If you do not have access to the Internet, you can complete the form below and mail to:

ECHO Incorporated, Product Registration, PO Box 1139, Lake Zurich IL 60047.



PRODUCT REGISTRATION CARD : TARJETA DE REGISTRO : CARTE D'ENREGISTREMENT DU PRODUIT

ONLINE OPTION: Register online and save a stamp! You will be alerted of product updates and/or be sent new ECHO product information and special offers. Simply go to:
www.echo-usa.com

OPCIÓN POR INTERNET: Regístrese en la página web y ahorre una estampilla! Le alertarán sobre actualizaciones del producto y/o se le enviara información sobre los nuevos productos ECHO y las ofertas especiales. Simplemente visite:
www.echo-usa.com

OPTION EN LIGNE : Enregistrer en ligne et épargner un timbre! Vous serez informé sur les nouveaux produits ECHO et les mises à jour de produit ainsi que les offres spéciales. Simplement visitez le: www.echo-usa.com

Please Print : Por Favor Enscriba Con Letra De Molde : En Lettre Carré S.V.P.

Confidential: Information provided will not be shared or sold

Purchaser's Name : Nombre del Comprador : Nom de l'acheteur		
Address : Dirección : Adresse		
City : Ciudad : Ville	State : Estado : Province	Zip Code : Código Postal : Code Postal
E-Mail Address : Dirección De Correo Electrónico : Courrier Électronique		
Phone Number : Número De Teléfono : Téléphone	Date of Purchase : Fecha de la Compra : Date de l'achat	
Where Purchased : Nombre del Almacén donde fue Comprado : Lieu d'achat		
Model Number : Numero del Modelo : No. de modèle	Serial Number : Numero de Serie : No. de série	

Registering your purchase enables us to contact you in the unlikely event of a service update or product recall and verifies your ownership in the event of loss. El registrar su compra nos permite estar en contacto con usted en caso de cualquier evento como el aviso de tiempo de servicio o la revocación del producto y verificación de propiedad en caso de robo o pérdida. L'enregistrement de votre achat nous permettra de vous contacter dans le cas improbable de modifications des instructions d'entretien ou de rappel du produit et vérifier que vous êtes le propriétaire en cas de vol ou de perte.

Primary use of tool: Professional Homeowner Rental Equip.
 Uso primario de la herramienta: Profesional Dueño de casa Alquilador
 Usage principal : Professionnel Residential Location

Do you wish to receive periodic ECHO product information and special offers by e-mail? Yes No
 ¿Desea usted recibir información periódica y ofertas especiales por correo electrónico sobre el producto ECHO? Yes No
 Souhaitez-vous recevoir périodiquement de l'information sur les produits ECHO et les offres spéciales par courrier électronique ? Oui Non

Did you visit the ECHO website before purchasing your product?
 Yes No
 Visité usted la página web ECHO antes de comprar su producto?
 Si No

Avez-vous visité le site d'ECHO avant de procurer votre produit?
 Oui Non

What factor(s) most influenced your purchase?
 Performance Price Dealer
 Reliability Prior Experience Quality
 Friend/Family Brand Warranty
 ¿Qué factor(es) influyó más en su compra?
 Funcionamiento Precio Distribuidor
 Confiabilidad Experiencia Anterior Calidad
 Amigo/Familia Marca Garantía

Quel facteur (facteurs) vous a influencé le plus?
 Performance Prix Marchand
 Fiabilité Expérience Qualité
 Ami/Famille Marque Garantie

ECHO INC., 400 Oakwood Rd., Lake Zurich, IL 60047
1.800.432.ECHO WWW.ECHO-USA.COM



ECHO INCORPORATED

400 Oakwood Road
Lake Zurich, IL 60047
www.echo-usa.com