

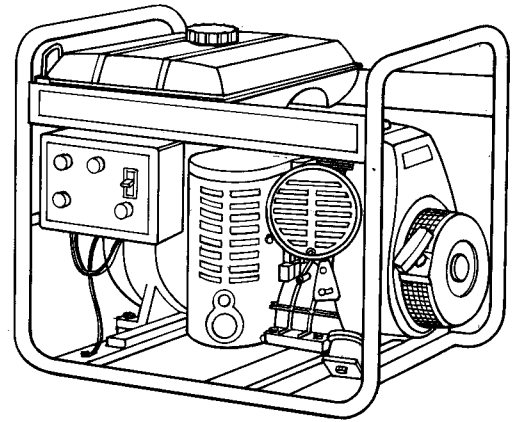

**GENERATOR PARTS MANUAL
MODEL EG-2300**

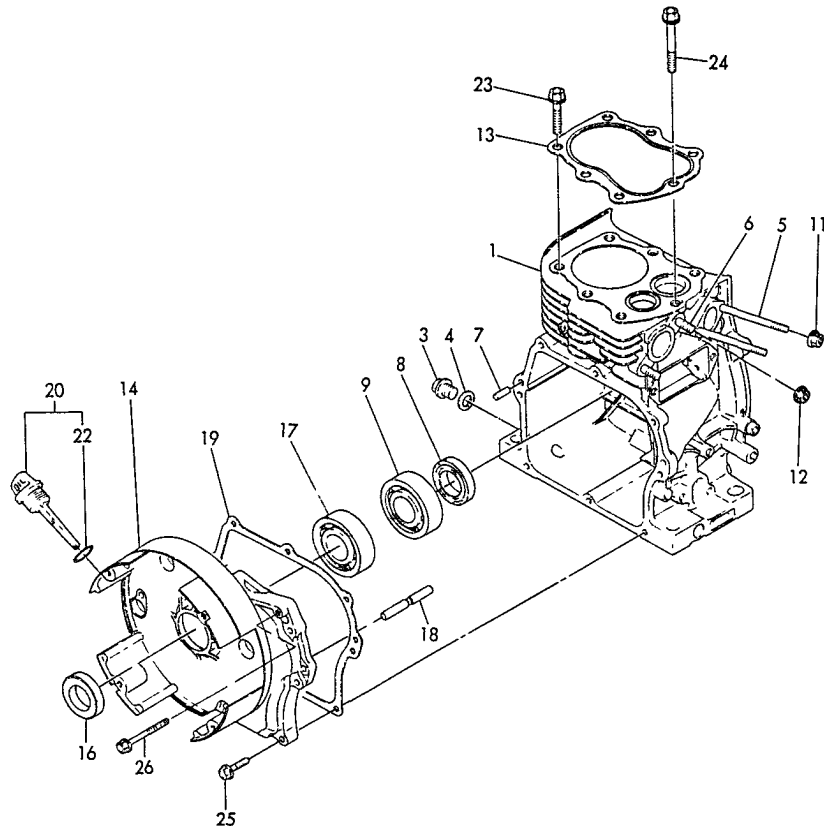

1 CYLINDER BLOCK



1B02
(1B01)

(1) CYLINDER BLOCK

(A) = EG-2300 (D) =
(B) = (E) =
(C) = (F) =

REF. NO.	LEV.	O	PART NO.	DESCRIPTION	Q'TY					
					(A)	(B)	(C)	(D)	(E)	(F)
1	.	Y	760770-01560	BLOCK ASSY, CYLINDER	1					
3	..	Y	160610-01690	PLUG, DRAIN	1					
4	..	Y	104200-59170	GASKET 12	1					
5	..	Y	160610-04570	BOLT M6 X 70	2					
6	..	Y	262160-80182	BOLT M6 X 18	2					
7	..	Y	223120-60160	PARALLEL PIN 6 X 16	2					
8	..	Y	160210-02220	OIL SEAL	1					
9	..	Y	241010-62050	BEARING 6205 C3	1					
11	..	Y	263660-60002	NUT M6	2					
12	..	Y	263660-80002	NUT M8	2					
13	.	Y	160710-01330	GASKET, CYL. HEAD	1					
14	.	Y	760770-01510	COVER ASSY., SIDE	1					
16	..	Y	160210-02220	SEAL, OIL	1					
17	..	Y	241010-62050	BEARING 6205 C3	1					
18	..	Y	160610-61100	SHAFT, GOVERNOR	1					
19	.	Y	160710-01410	GASKET, SIDE COVER	1					
20	.	Y	160710-01760	CAP ASSY, OIL FILLER	1					
22	..	Y	243110-00180	O-RING P18	1					
23	.	Y	160610-04172	BOLT M8 X 38	4					
24	.	Y	160610-04211	BOLT M8 X 65	3					
25	.	Y	264760-60252	BOLT M6 X 25	8					
26	.	Y	264760-60552	BOLT M6 X 55	1					

2 BREATHER

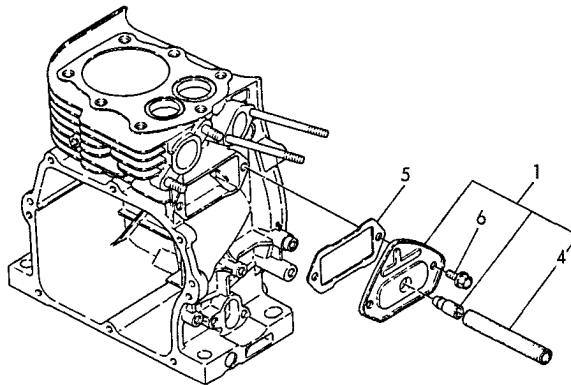

**1B03
(1B01)**

(2) BREATHER

(A) = EG-2300 (D) =
 (B) = (E) =
 (C) = (F) =

REF. NO.	LEV.	O	PART NO.	DESCRIPTION	Q'TY					
					(A)	(B)	(C)	(D)	(E)	(F)
1	.		Y 160710-03010	BREATHER ASSY	1					
4	..		Y 160710-03180	PIPE, BREATHER	1					
5	.		Y 160710-03070	GASKET	1					
6	.		Y 264760-60142	BOLT M6 X 14	2					

3 LABEL

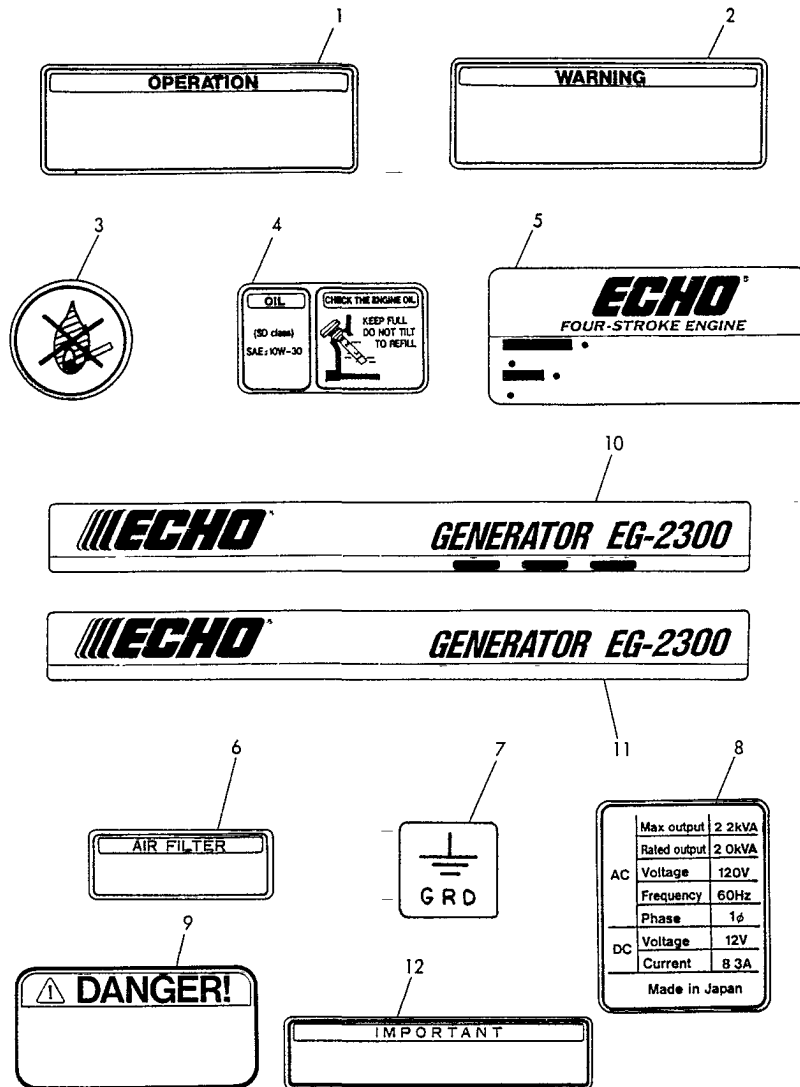

**1B04
(1B01)**

(3) LABEL

(A) = EG-2300 (D) =
 (B) = (E) =
 (C) = (F) =

REF. NO.	LEV.	O	PART NO.	DESCRIPTION	Q'TY					
					(A)	(B)	(C)	(D)	(E)	(F)
1	.	Y	183621-07250	LABEL, OPERATION	1					
2	.	Y	183621-07260	LABEL, CAUTION	1					
3	.	Y	183210-07270	LABEL, NON-FIRE	1					
4	.	Y	183210-07290	LABEL, OIL	1					
5	.	Y	160671-07371	LABEL (ECHO)	1					
6	.	Y	183210-07370	LABEL, AIR CLEANER	1					
7	.	Y	183210-07390	LABEL, EARTH	1					
8	.	Y	183720-07530	LABEL, GENERATOR	1					
9	.	Y	183720-07270	LABEL, DANGER	1					
10	.	Y	183725-07150	LABEL, GENERATOR	1					
11	.	Y	183725-07160	LABEL, GENERATOR	1					
12	.	Y	183210-07280	LABEL, IMPORTANT	1					

4 FRAME

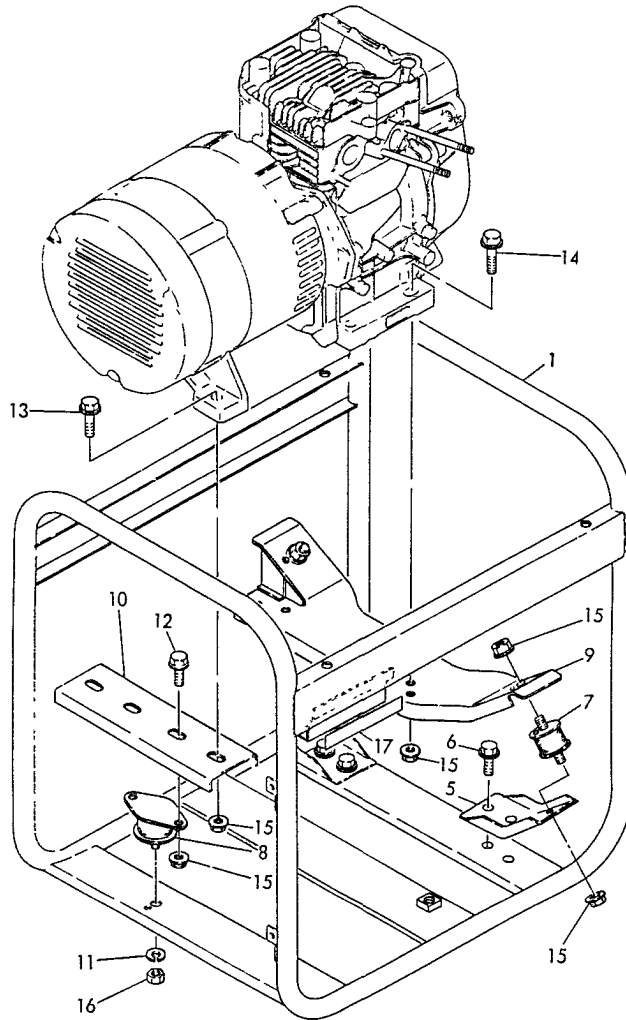

**1B05
(1B01)**

(4) FRAME

(A) = EG-2300 (D) =
 (B) = (E) =
 (C) = (F) =

REF. NO.	LEV.	O	PART NO.	DESCRIPTION	QTY					
					(A)	(B)	(C)	(D)	(E)	(F)
1	.	Y	783720-08722	FRAME	1					
5	.	Y	183621-08260	DAMPER, LOWER	2					
6	.	Y	261060-80162	BOLT M8 X 16	4					
7	.	Y	183720-08210	DAMPER, FRONT	2					
8	.	Y	183720-08220	DAMPER, REAR	1					
9	.	Y	183621-08230	STAY, DAMPER	1					
10	.	Y	183720-08250	STAY, REAR DAMPER	1					
11	.	Y	222161-00000	SPRING WAHSER 10	1					
12	.	Y	261060-80202	BOLT M8 X 20	2					
13	.	Y	261060-80302	BOLT M8 X 30	2					
14	.	Y	261060-80382	BOLT M8 X 38	2					
15	.	Y	263660-80002	NUT M8	10					
16	.	Y	267171-00002	NUT M10	1					
17	.	Y	183625-07910	SHEET, FRAME	1					

5 CYLINDER HEAD

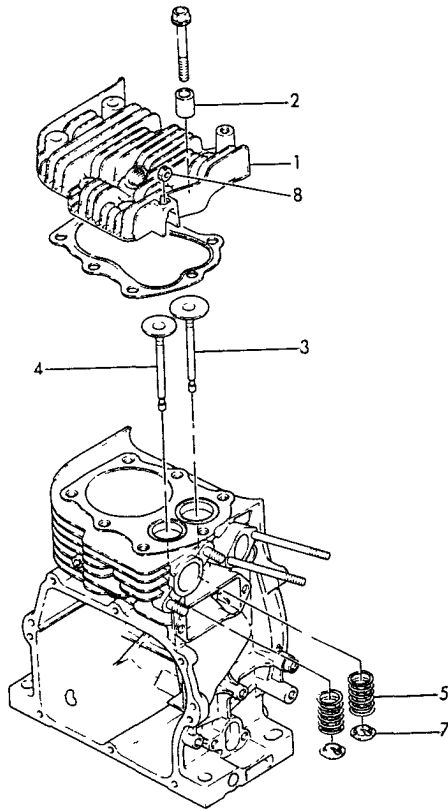

**1B06
(1B01)**

(5) CYLINDER HEAD

(A) = EG-2300 (D) =
 (B) = (E) =
 (C) = (F) =

REF. NO.	LEV.	O	PART NO.	DESCRIPTION	QTY					
					(A)	(B)	(C)	(D)	(E)	(F)
1	.	Y	160710-11010	HEAD, CYLINDER	1					
2	.	Y	160710-11050	SPACER, HEAD	1					
3	.	Y	160710-11100	VALVE, INTAKE	1					
4	.	Y	160710-11110	VALVE, EXHAUST	1					
5	.	Y	160710-11120	SPRING, VALVE	2					
7	.	Y	160610-11180	RETAINER, SPRING	2					
8	.	Y	267560-60002	NUT M6	1					

6 AIR CLEANER & MUFFLER

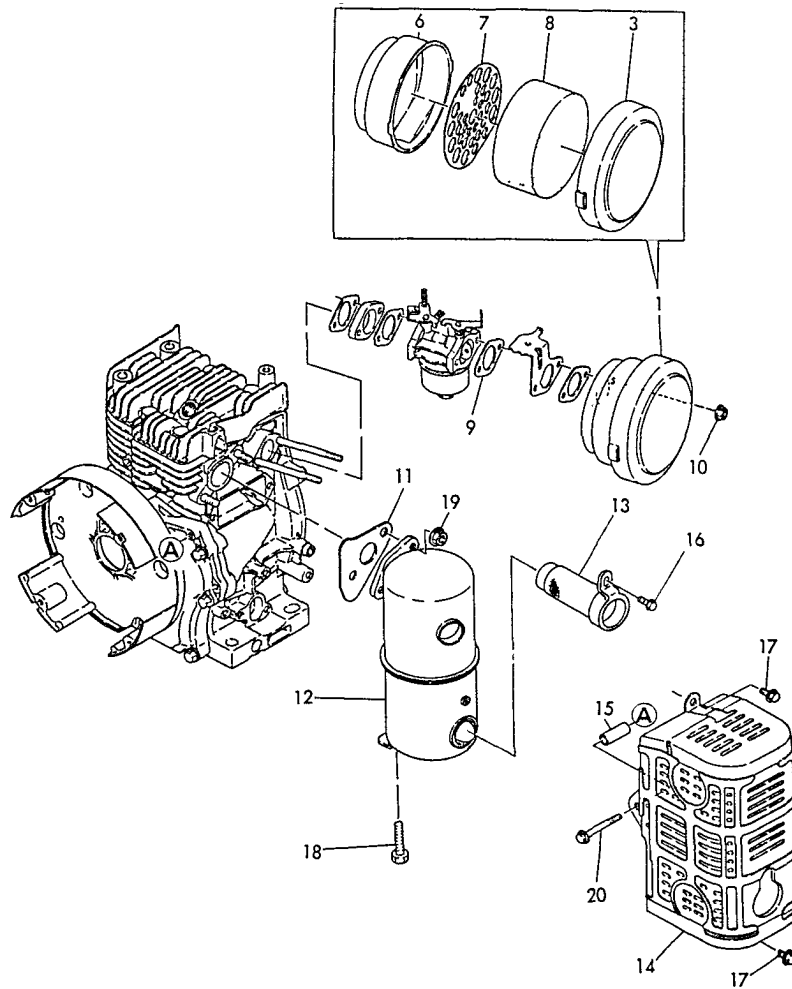

**1B07
(1B01)**

(6) AIR CLEANER & MUFFLER

(A) = EG-2300 (D) =
(B) = (E) =
(C) = (F) =

REF. NO.	LEV.	O	PART NO.	DESCRIPTION	Q'TY					
					(A)	(B)	(C)	(D)	(E)	(F)
1	.	Y	760710-12560	AIR CLEANER ASSY.	1					
3	..	Y	760710-12540	CAP, AIR CLEANER	1					
6	..	Y	160710-12540	BODY, AIR CLEANER	1					
7	..	Y	160710-12550	PLATE, ELEMENT	1					
8	..	Y	160260-12570	ELEMENT, AIR CLEANER	1					
9	.	Y	160610-56150	GASKET, AIR CLEANER	1					
10	.	Y	263660-60002	NUT M6	2					
11	.	Y	160710-13200	GASKET, MUFFLER	1					
12	.	Y	160770-13550	MUFFLER	1					
13	.	Y	160770-13650	SPARK ARRESTOR	1					
14	.	Y	160770-13810	COVER, MUFFLER	1					
15	.	Y	160630-45190	SPACER	1					
16	.	Y	261060-60102	BOLT M6 X 10	1					
17	.	Y	261060-60162	BOLT M6 X 16	2					
18	.	Y	261060-80302	BOLT M8 X 30	1					
19	.	Y	263660-80002	NUT M8	2					
20	.	Y	264760-60552	BOLT M6 X 55	1					

7 CAMSHAFT

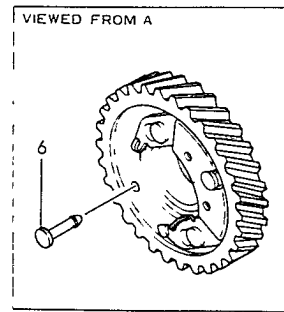
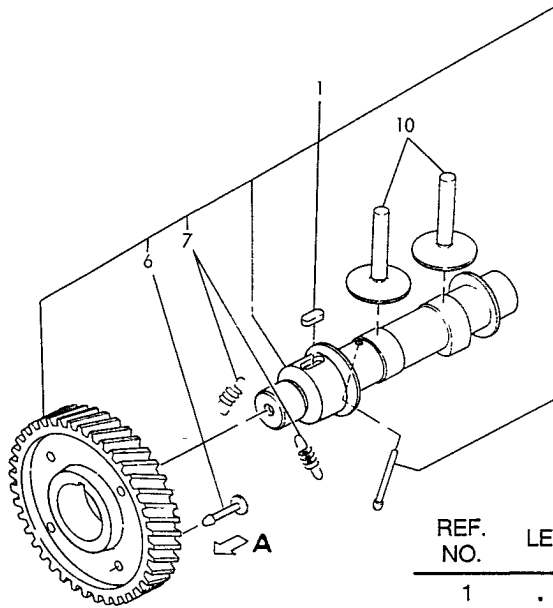

**1B08
(1B01)**

(7) CAMSHAFT

(A) = EG-2300 (D) =
(B) = (E) =
(C) = (F) =

REF. NO.	LEV.	O	PART NO.	DESCRIPTION	Q'TY					
					(A)	(B)	(C)	(D)	(E)	(F)
1	.	Y	160759-14110	CAMSHAFT ASSY	1					
6	..	Y	160759-14550	GUIDE PIN, DECOMP.	4					
7	..	Y	160759-14560	SPRING, DECOMP.	2					
10	.	Y	160710-14200	TAPPET	2					

8 CRANKSHAFT & MAIN BEARING

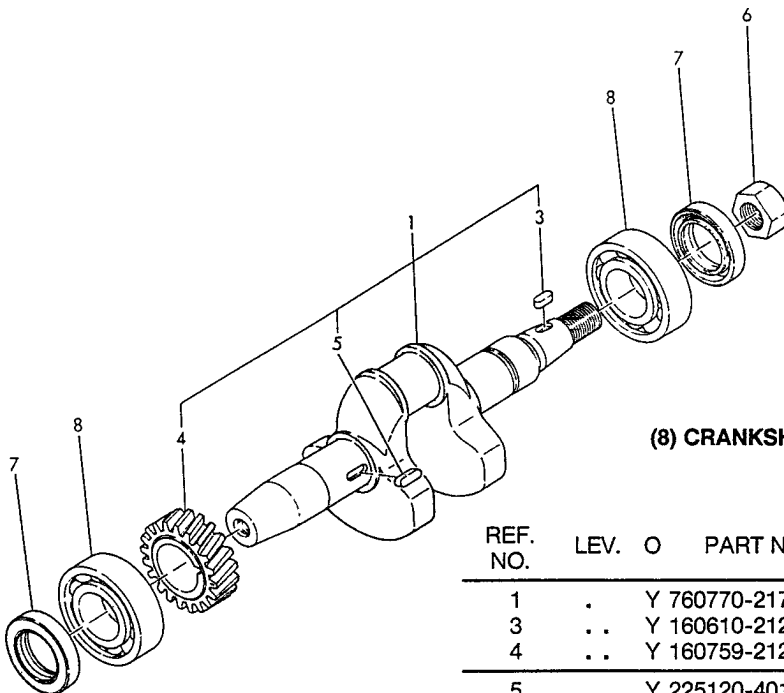

**1B09
(1B01)**

(8) CRANKSHAFT & MAIN BEARING

(A) = EG-2300 (D) =
(B) = (E) =
(C) = (F) =

REF. NO.	LEV.	O	PART NO.	DESCRIPTION	Q'TY					
					(A)	(B)	(C)	(D)	(E)	(F)
1	.	Y	760770-21701	CRANKSHAFT ASSY	1					
3	..	Y	160610-21290	KEY 4 X 10	1					
4	..	Y	160759-21200	GEAR, CRANKSHAFT	1					
5	..	Y	225120-40120	KEY 4 X 12	1					
6	.	Y	160610-04910	NUT, FLYWHEEL	1					
7	.	Y	160210-02220	OIL SEAL	2					
8	.	Y	241010-62050	BEARING 6205 C3	2					

9 PISTON & CONNECTING ROD

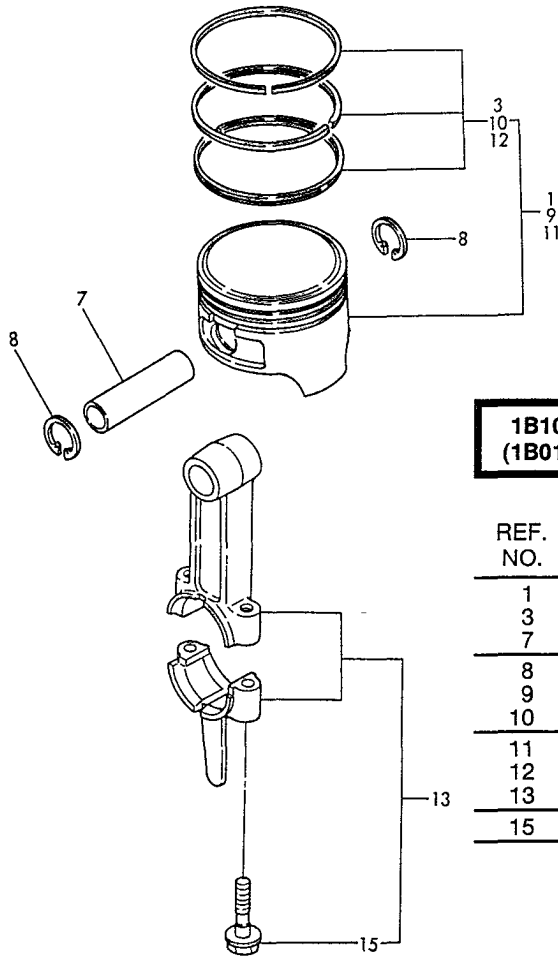

**1B10
(1B01)**

(9) PISTON & CONNECTING ROD

(A) = EG-2300 (D) =
(B) = (E) =
(C) = (F) =

REF. NO.	LEV.	O	PART NO.	DESCRIPTION	Q'TY					
					(A)	(B)	(C)	(D)	(E)	(F)
1	.		Y 160710-22011	PISTON W/RING	1					
3	..		Y 760710-22500	RING SET, PISTON	1					
7	.		Y 160710-22300	PIN, PISTON	1					
8	.		Y 222520-00160	RING 16	2					
9	.		Y 160710-22470	PISTON ASSY O.S=0.25	1					
10	..		Y 760710-22540	RING SET O.S=0.25	1					
11	.		Y 160710-22480	PISTON ASSY O.S=0.5	1					
12	..		Y 760710-22550	RING SET OS=0.5	1					
13	.		Y 760710-23101	ROD ASSY, CONNECTING	1					
15	..		Y 160710-23201	BOLT, ROD	2					

10 COOLING FAN CASE

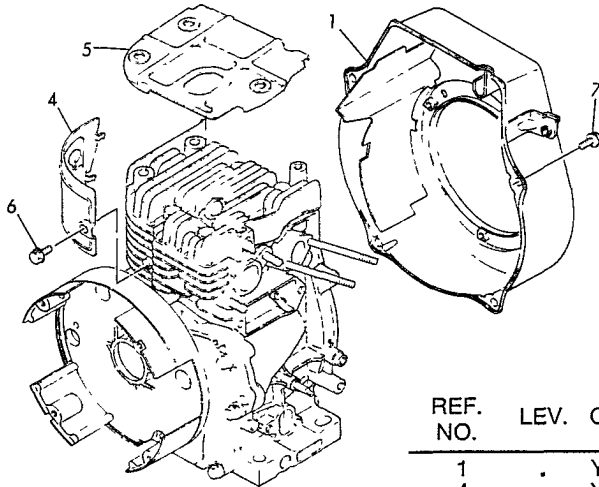

**1B11
(1B01)**

(10) COOLING FAN CASE

(A) = EG-2300 (D) =
(B) = (E) =
(C) = (F) =

REF. NO.	LEV.	O	PART NO.	DESCRIPTION	Q'TY					
					(A)	(B)	(C)	(D)	(E)	(F)
1	.		Y 760740-45601	FAN CASE	1					
4	.		Y 160710-45201	PLATE	1					
5	.		Y 160710-45250	COVER, HEAD	1					
6	.		Y 264760-60142	BOLT M6 X 14	1					
7	.		Y 264760-60142	BOLT M6 X 14	4					

11 FUEL TANK

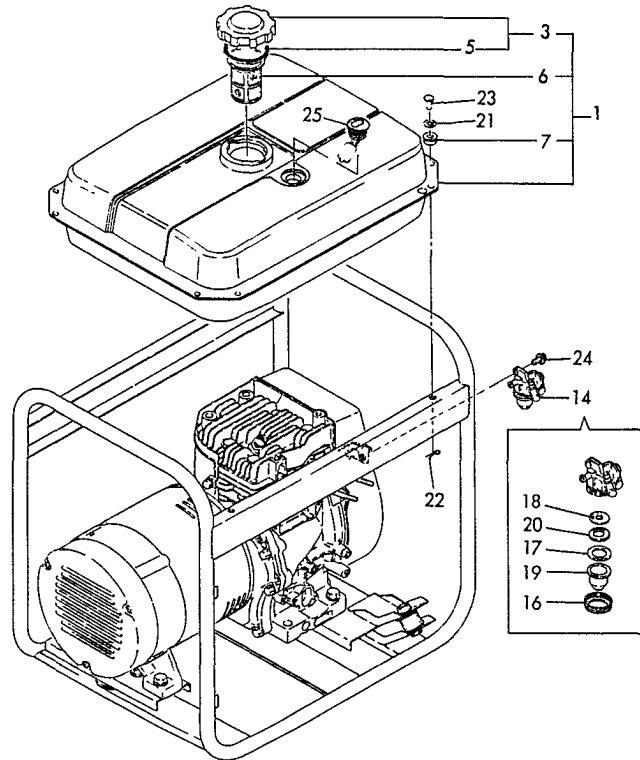

**1B12
(1B01)**

(11) FUEL TANK

(A) = EG-2300 (D) =
 (B) = (E) =
 (C) = (F) =

REF. NO.	LEV.	O	PART NO.	DESCRIPTION	Q'TY					
					(A)	(B)	(C)	(D)	(E)	(F)
1	.	Y	783720-55760	TANK ASSY, FUEL	1					
3	..	Y	160642-55060	CAP ASSY, FUEL TANK	1					
5	...	Y	160393-55050	GASKET	1					
6	..	Y	160710-55100	FILTER, FUEL	1					
7	..	Y	183720-55210	GROMMET, FUEL TANK	4					
14	.	Y	160710-55301	COCK ASSY, FUEL	1					
16	..	Y	160710-55360	RETAINER	1					
17	..	Y	160710-55370	GASKET	1					
18	..	Y	160710-55381	FILTER, FUEL	1					
19	..	Y	160710-55390	BOWL, STRAINER	1					
20	..	Y	160692-55421	PLATE	1					
21	.	Y	183350-55130	WASHER	4					
22	.	Y	223600-60000	PIN 6, SNAP	4					
23	.	Y	183350-55120	PIN 6 X 14	4					
24	.	Y	261060-60082	BOLT M6 X 14	1					
25	.	Y	183621-55150	GAUGE, FUEL	1					

12 CARBURETOR

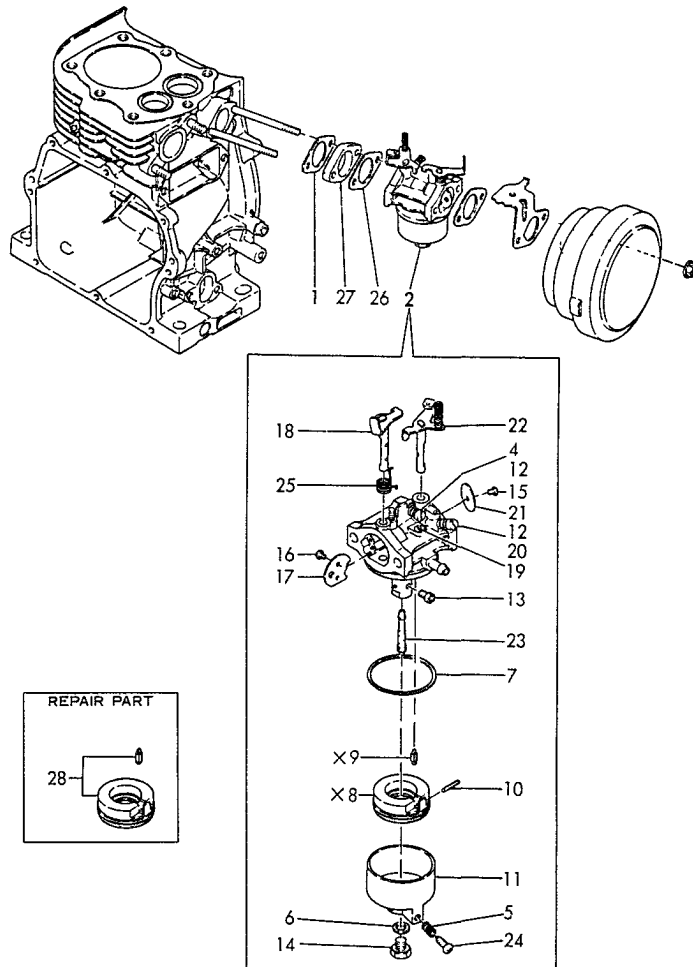

1B13
(1B01)

(12) CARBURETOR

(A) = EG-2300 (D) =
 (B) = (E) =
 (C) = (F) =

12 CARBURETOR

**1B13
(1B01)**

(12) CARBURETOR

(A) = EG-2300 (D) =
 (B) = (E) =
 (C) = (F) =

REF. NO.	LEV.	O	PART NO.	DESCRIPTION	Q'TY					
					(A)	(B)	(C)	(D)	(E)	(F)
1	.	Y	160310-13200	GASKET, MUFFLER	1					
2	.	Y	160770-56010	CARBURETOR ASSY	1					
4	..	Y	181230-56370	SCREW	1					
5	..	Y	181230-56380	SPRING	1					
6	..	Y	160610-56550	WASHER	1					
7	..	Y	160610-56610	GASKET	1					
8	..	Y	160610-56620	FLOAT	1					
9	..	Y	160710-56732	NEEDLE	1					
10	..	Y	160610-56631	PIN	1					
11	..	Y	160610-56640	BODY, FLOAT CHAMBER	1					
12	..	Y	181230-56380	SPRING	2					
13	..	Y	160710-56650	JET, MAIN	1					
14	..	Y	160610-56660	BOLT	1					
15	..	Y	160120-56670	SCREW	1					
16	..	Y	160710-56710	SCREW	2					
17	..	Y	160710-56680	VALVE, CHOKE	1					
18	..	Y	160770-56690	SHAFT, CHOKE	1					
19	..	Y	160710-56740	JET, PILOT	1					
20	..	Y	160835-56750	SCREW	1					
21	..	Y	160610-56760	VALVE, THROTTLE	1					
22	..	Y	160770-56770	SHAFT, THROTTLE	1					
23	..	Y	160710-56801	NOZZLE, MAIN	1					
24	..	Y	160610-56900	SCREW	1					
25	..	Y	160710-56720	SPRING	1					
26	.	Y	160610-56150	GASKET, CARBURETOR	1					
27	.	Y	160610-56160	SPACER, CARBURETOR	1					
28	.	Y	160610-56250	NEEDLE ASSY (RUBBER)	1					

13 FUEL LINE

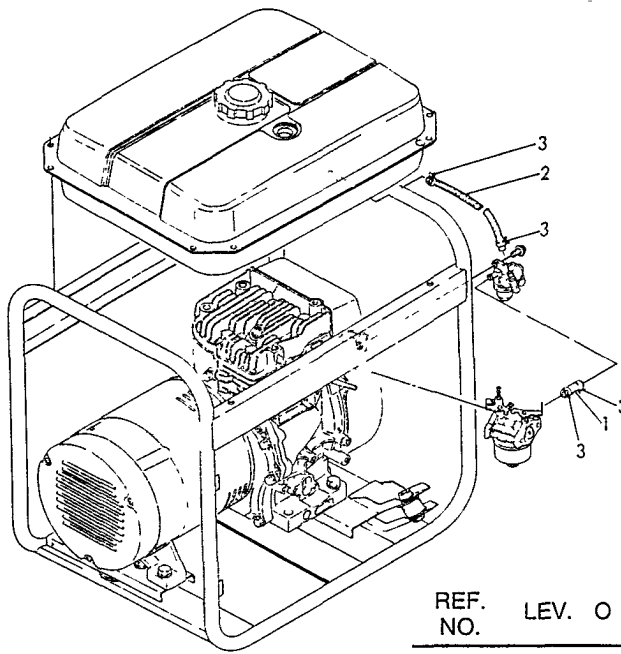

(13) FUEL LINE

(A) = EG-2300 (D) =
 (B) = (E) =
 (C) = (F) =

REF. NO.	LEV.	O	PART NO.	DESCRIPTION	Q'TY						
					(A)	(B)	(C)	(D)	(E)	(F)	
1	.		Y 160610-59160	PIPE, FUEL	1						
2	.		Y 183720-59610	PIPE, FUEL	1						
3	.		Y 106100-44680	CLAMP	4						

14 GOVERNOR

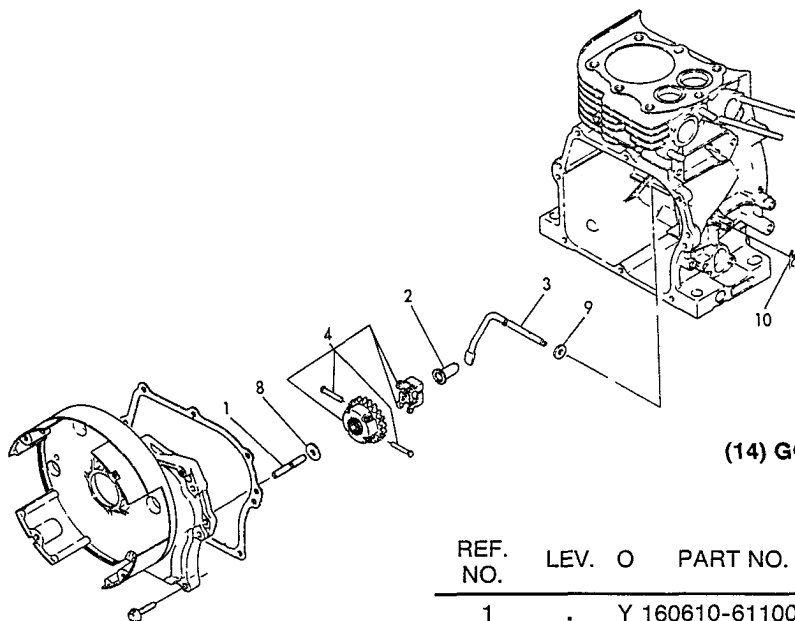

(14) GOVERNOR

(A) = EG-2300 (D) =
 (B) = (E) =
 (C) = (F) =

REF. NO.	LEV.	O	PART NO.	DESCRIPTION	Q'TY						
					(A)	(B)	(C)	(D)	(E)	(F)	
1	.		Y 160610-61100	SHAFT, GOVERNOR	1						
2	.		Y 160610-61300	SPINDLE	1						
3	.		Y 160710-61310	YOKE	1						
4	.		Y 160641-61600	GEAR ASSY., GOVERNOR	1						
8	.		Y 160720-76940	WASHER	1						
9	.		Y 221370-60000	WASHER 6	1						
10	.		Y 223600-60000	SNAP PIN 6	1						

15 CONTROL DEVICE

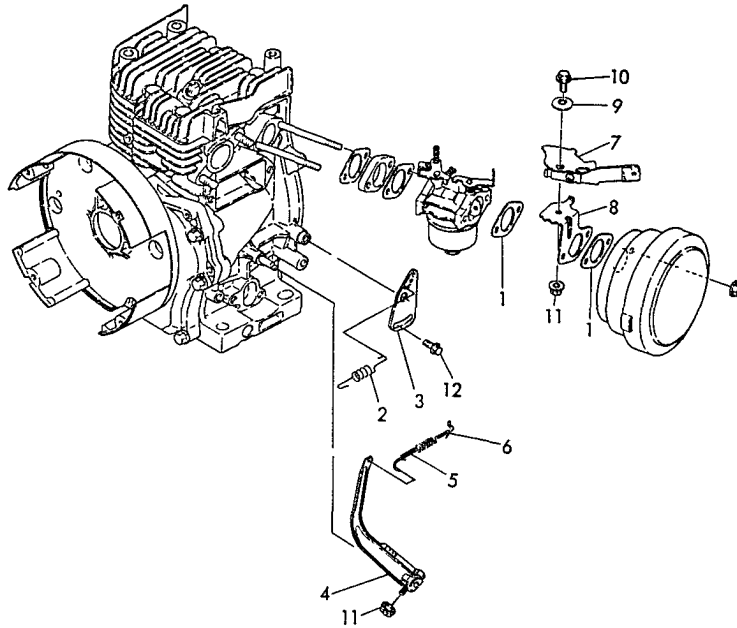

**1B16
(1B01)**

(15) CONTROL DEVICE

(A) = EG-2300 (D) =
(B) = (E) =
(C) = (F) =

REF. NO.	LEV.	O	PART NO.	DESCRIPTION	Q'TY					
					(A)	(B)	(C)	(D)	(E)	(F)
1	.	Y	160610-56150	GASKET, CARBURETOR	2					
2	.	Y	160610-66011	SPRING, REGULATOR	1					
3	.	Y	160970-66120	HANDLE, REGULATOR	1					
4	.	Y	160710-66151	LEVER, GOVERNOR	1					
5	.	Y	160610-66201	LINK, THROTTLE	1					
6	.	Y	160710-66220	SPRING, TENSION	1					
7	.	Y	160770-66300	LEVEL ASSY	1					
8	.	Y	160770-66330	BRACKET	1					
9	.	Y	160670-66350	COLLAR	1					
10	.	Y	261060-60122	BOLT M6 X 12	1					
11	.	Y	263660-60002	NUT M6	2					
12	.	Y	264760-60142	BOLT 6 X 14	1					

16 GENERATOR

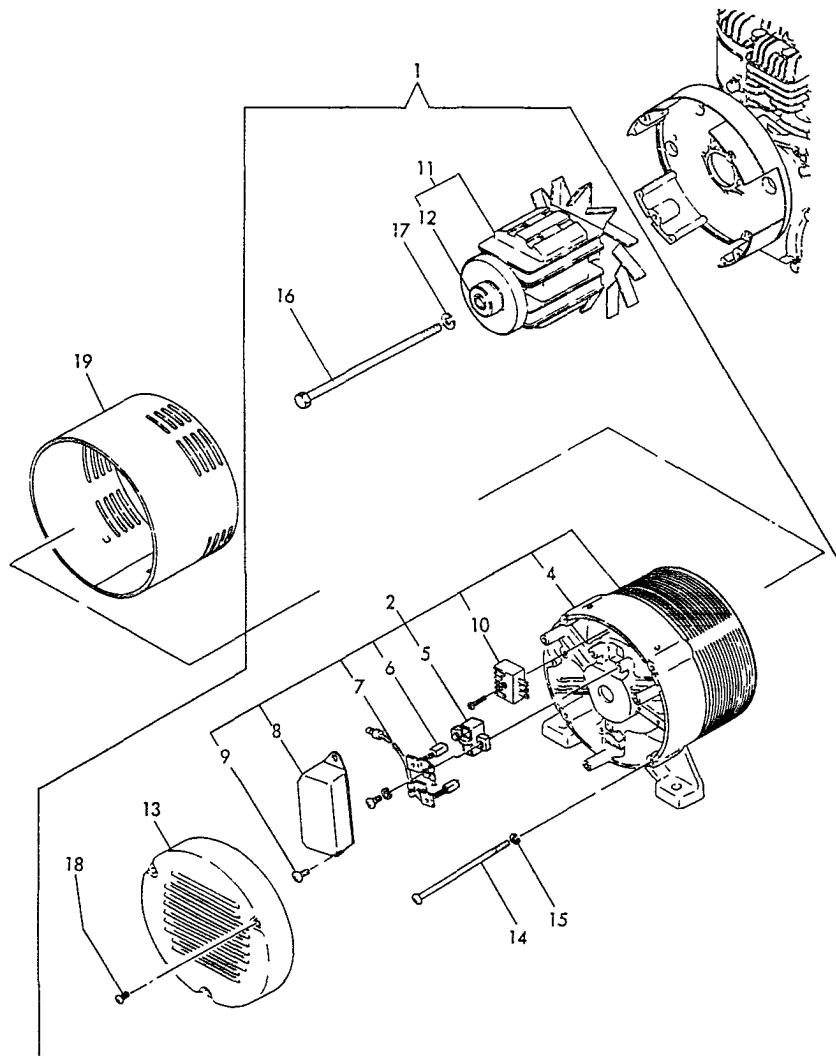

1C01
(1B01)

(16) GENERATOR

(A) = EG-2300 (D) =
(B) = (E) =
(C) = (F) =

REF. NO.	LEV.	O	PART NO.	DESCRIPTION	Q'TY					
					(A)	(B)	(C)	(D)	(E)	(F)
1	.	Y	183720-74130	GENERATOR 2.0KVA	1					
2	..	Y	183720-74230	STATOR ASSY	1					
4	...	Y	183720-74260	COVER, REAR	1					
5	...	Y	183620-74240	HOLDER, BRUSH	1					
6	...	Y	183620-74220	BRUSH (+)	1					
7	...	Y	183620-74230	BRUSH (-)	1					
8	...	Y	183720-74170	A.V.R.	1					
9	...	Y	183820-74300	SCREW M5 X 14	2					
10	...	Y	183720-74460	RECTIFIER	1					
11	..	Y	183720-74350	ROTOR ASSY	1					
12	...	Y	183620-74360	BEARING	1					
13	..	Y	183621-74400	COVER, END	1					
14	..	Y	183720-74410	BOLT, THROUGH	4					
15	..	Y	222170-60000	SPRING WASHER 6	4					
16	..	Y	183720-74430	BOLT	1					
17	..	Y	222170-80000	SPRING WASHER 8	1					
18	..	Y	183520-91290	SCREW M4 X 8	3					
19	.	Y	183720-74760	BAND	1					

17 STARTING DEVICE

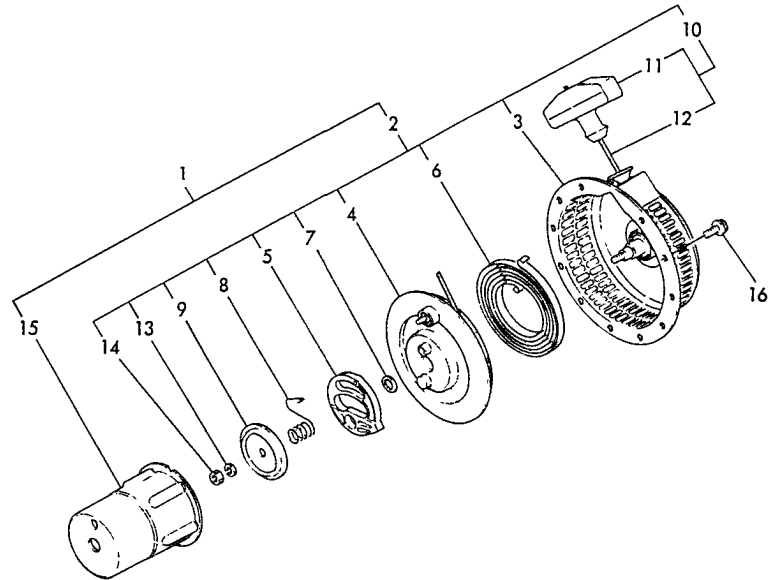

**1C02
(1B01)**

(17) STARTING DEVICE

(A) = EG-2300 (D) =
 (B) = (E) =
 (C) = (F) =

REF. NO.	LEV.	O	PART NO.	DESCRIPTION	Q'TY					
					(A)	(B)	(C)	(D)	(E)	(F)
1	.	Y	160740-76050	STARTER ASSY, RECOIL	1					
2	..	Y	160740-76250	RE-COIL ASSY.	1					
3	...	Y	160740-76510	CASE, STARTER	1					
4	...	Y	160710-76520	REEL	1					
5	...	Y	160610-76530	RATCHET	1					
6	...	Y	160710-76540	SPRING, SPIRAL	1					
7	...	Y	160610-76550	WASHER	1					
8	...	Y	160740-76560	SPRING, FRICTION	1					
9	...	Y	160610-76580	PLATE, FRICTION	1					
10	...	Y	160260-76610	ROPE ASSY., STARTER	1					
11	Y	160260-76620	KNOB, STARTER	1					
12	Y	160260-76630	ROPE, STARTER	1					
13	...	Y	222170-60000	SPRING WASHER 6	1					
14	...	Y	267160-60002	NUT M6	1					
15	..	Y	160710-76590	PULLEY, STARTER	1					
16	.	Y	261060-60082	BOLT M6 X 8	3					

18 FLYWHEEL MAGNETO

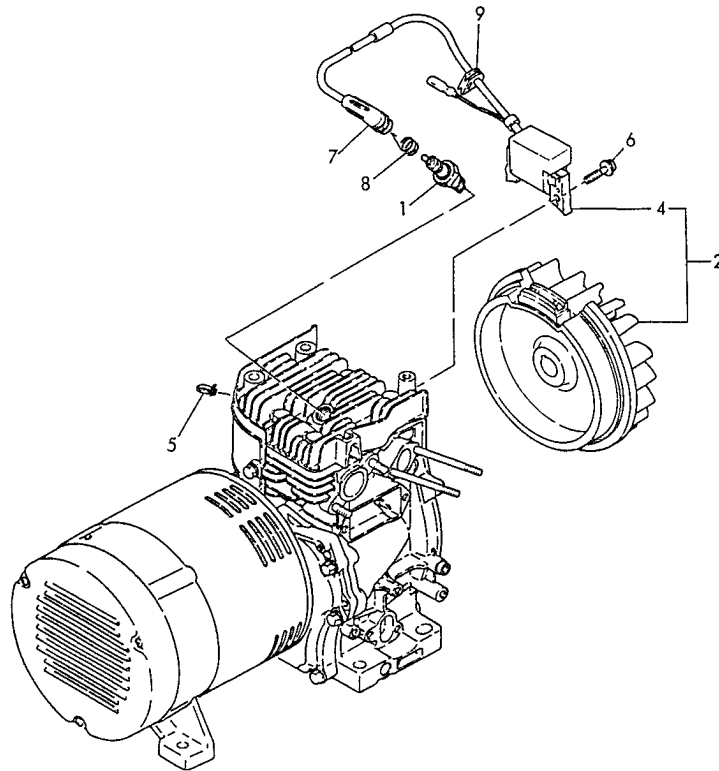

**1C03
(1B01)**

(18) FLYWHEEL MAGNETO

(A) = EG-2300 (D) =
 (B) = (E) =
 (C) = (F) =

REF. NO.	LEV.	O	PART NO.	DESCRIPTION	Q'TY					
					(A)	(B)	(C)	(D)	(E)	(F)
1	.		Y 160232-78010	PLUG, SPARK	1					
2	.		Y 160740-78061	MAGNETO ASSY	1					
4	.		Y 160710-78511	COIL, IGNITION	1					
5	.		Y 160710-78700	CLAMP	1					
6	.		Y 264760-60252	BOLT M6 X 30	2					
7	.		Y 160700-78040	CAP, PLUG	1					
8	.		Y 160700-78050	TERMINAL, PLUG	1					
9	.		Y 160700-78720	GROMMET	1					

19 OIL SENSOR

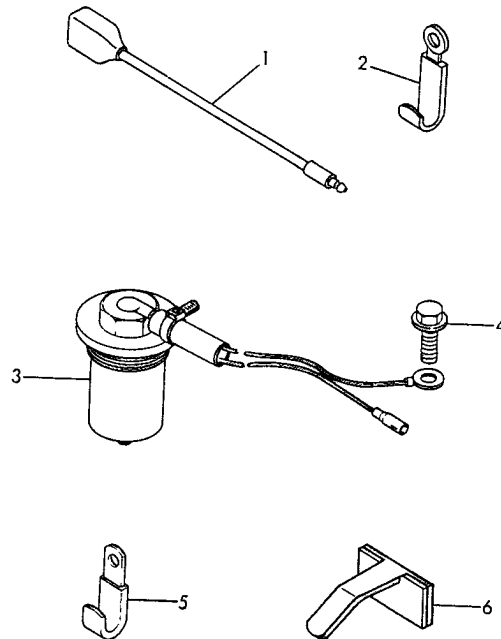

**1C04
(1B01)**

(19) OIL SENSOR

(A) = EG-2300 (D) =
 (B) = (E) =
 (C) = (F) =

REF. NO.	LEV.	O	PART NO.	DESCRIPTION	QTY					
					(A)	(B)	(C)	(D)	(E)	(F)
1	.		Y 160671-78220	WIRE	1					
2	.		Y 160710-78710	CLAMP	1					
3	.		Y 160770-78820	SENSOR, OIL LEVEL	1					
4	.		Y 261130-60122	BOLT M6 X 12	1					
5	.		Y 160260-78700	CLAMP	1					
6	.		Y 160560-78700	CLAMP	1					

20 PANEL

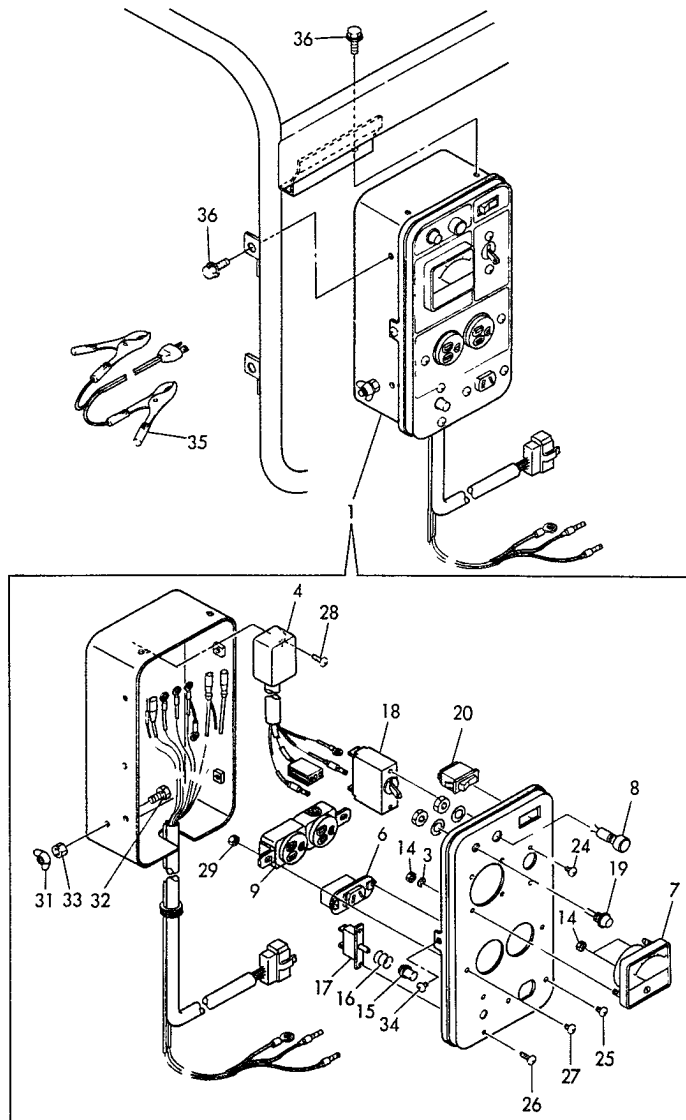

1C05
(1B01)

(20) PANEL

(A) = EG-2300 (D) =
 (B) = (E) =
 (C) = (F) =

20 PANEL

1C05
(1B01)

(20) PANEL

(A) = EG-2300 (D) =
(B) = (E) =
(C) = (F) =

REF. NO.	LEV.	O	PART NO.	DESCRIPTION	QTY					
					(A)	(B)	(C)	(D)	(E)	(F)
1	.	Y	183725-91050	BOX ASSY, PANEL	1					
3	...	Y	160664-14570	WASHER, DECOMP.	2					
4	...	Y	160671-78810	SENSOR UNIT, OIL	1					
6	...	Y	183825-91250	DC CONNECT	1					
7	...	Y	183820-91280	VOLTAGE METER (150V)	1					
8	...	Y	183820-91310	LAMP, PILOT	1					
9	...	Y	183920-91320	AC CONNECT	1					
14	...	Y	183925-91990	NUT	4					
15	...	Y	183000-96310	CAP, BREAKER	1					
16	...	Y	183000-96320	SPRING, BREAKER	1					
17	...	Y	183000-96330	BREAKER	1					
18	...	Y	183000-96400	AC BREAKER	1					
19	...	Y	183000-97130	LAMP, OIL ALERT	1					
20	...	Y	183000-97440	SWITCH	1					
24	...	Y	265570-30062	SCREW 3 X 6	2					
25	...	Y	265570-30062	SCREW 3 X 6	2					
26	...	Y	265570-30122	SCREW 3 X 12	2					
27	...	Y	265570-40062	SCREW 4 X 6	2					
28	...	Y	265570-50102	SCREW 5 X 10	1					
29	...	Y	267560-40002	NUT M4	2					
31	...	Y	183261-08810	WING NUT M6	1					
32	...	Y	261130-60162	BOLT M6 X 16	1					
33	...	Y	267530-60002	NUT M6	1					
34	..	Y	265570-40062	SCREW 4 X 6	3					
35	.	Y	183210-91180	CABLE, CHARGING	1					
36	.	Y	261060-60082	BOLT M6 X 8	4					

21 TOOLS

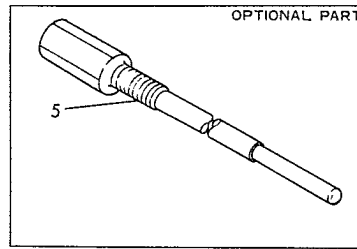
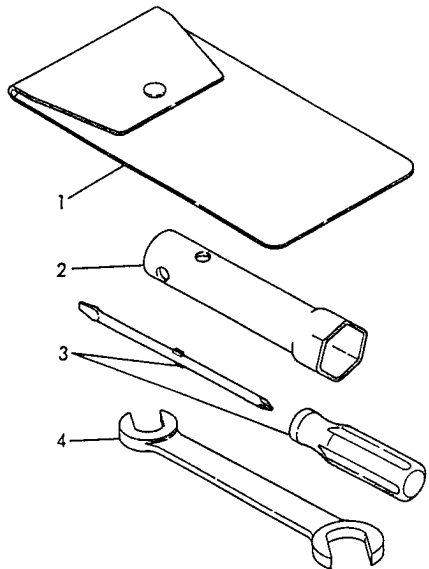

**1C06
(1B01)**

(21) TOOLS

(A) = EG-2300 (D) =
(B) = (E) =
(C) = (F) =

REF. NO.	LEV.	O	PART NO.	DESCRIPTION	Q'TY					
					(A)	(B)	(C)	(D)	(E)	(F)
1	.	Y	160110-92610	BAG, TOOL	1					
2	.	Y	160120-92700	BOX WRENCH 21	1					
3	.	Y	104200-92350	DRIVER	1					
4	.	Y	281101-00120	WRENCH 10 X 12	1					
5	.	Y	183720-92350	REMOVER, ROTOR	1					

22 GASKET SET

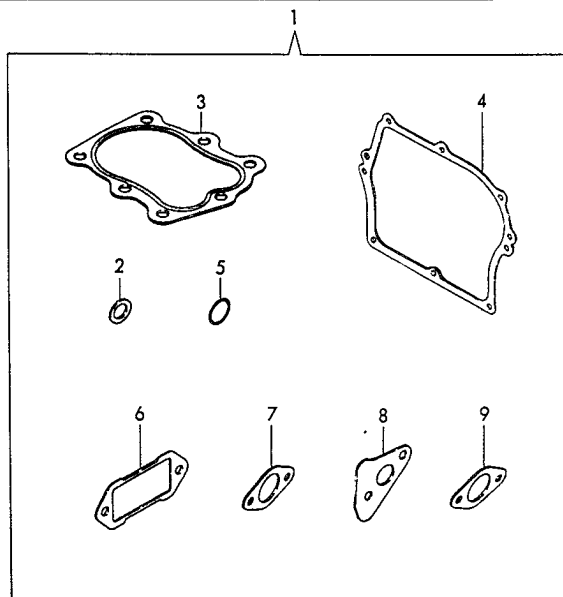

**1C07
(1B01)**

(22) GASKET SET

(A) = EG-2300 (D) =
(B) = (E) =
(C) = (F) =

REF. NO.	LEV.	O	PART NO.	DESCRIPTION	Q'TY					
					(A)	(B)	(C)	(D)	(E)	(F)
1	.	Y	760770-92600	GASKET SET	1					
2	..	Y	104200-59170	GASKET 12	1					
3	..	Y	160710-01330	GASKET, CYL HEAD	1					
4	..	Y	160710-01410	GASKET, SIDE COVER	1					
5	..	Y	243110-00180	O-RING P18	1					
6	..	Y	160710-03070	GASKET, BREAT. COVER	1					
7	..	Y	160610-56150	GASKET, CARBURETOR	4					
8	..	Y	160710-13200	GASKET, MUFFLER	1					
9	..	Y	160310-13200	GASKET, SPACER	1					