



# Pro Attachment Series

## *Operator's Manual*

**MODELS, PAS-260**  
Serial Number 003001001 & Up

**WARNING**  **DANGER**



The muffler or catalytic muffler and surrounding cover may become extremely hot.

Always keep clear of exhaust and muffler area, otherwise serious personal injury may occur.



**WARNING**



The engine exhaust from this product contains chemicals known to the State of California to cause cancer, birth defects or other reproductive harm.

**WARNING**  **DANGER**



Read rules for safe operation and instructions carefully. ECHO provides an Operator's Manual with this unit and a separate Operator's Manual and Safety Manual (if available) with the attachment. All manuals must be read and understood for proper and safe operation. Failure to do so could result in serious injury.

## INTRODUCTION

Welcome to the ECHO family. This ECHO product was designed and manufactured to provide long life and on-the-job-dependability. Read and understand this manual as well as your attachment operator's manual and SAFETY MANUAL (if available) before operation. You will find these manuals easy to read and full of helpful operating tips and SAFETY messages.

### WARNING DANGER

Read rules for safe operation and instructions carefully. ECHO provides an Operator's Manual with this unit and a separate Operator's Manual and Safety Manual (if available) with the attachment. All manuals must be read and understood for proper and safe operation.

### THE OPERATOR'S MANUAL —

contains specifications and information for operation, starting, stopping, maintenance and storage specific to this product.

### THE ATTACHMENT OPERATOR'S MANUAL —

contains specifications and information for operation and maintenance specific to the attachment.

### THE SAFETY MANUAL —

*(if available for attachment)* explains possible hazards and what measures you should take to insure safe operation.

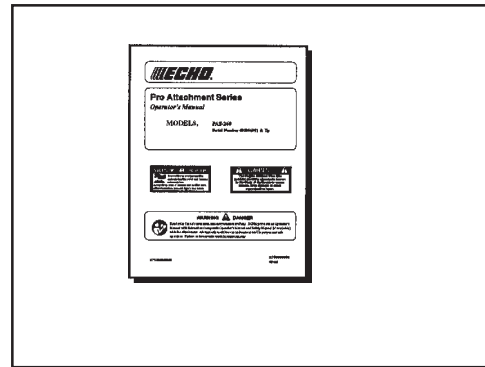

## TABLE OF CONTENTS

Introduction .....	2	- Starting Cold Engine .....	17
- The Operator's Manual .....	2	- Starting Warm Engine .....	18
Manual Safety Symbols and Important Information .....	3	- Stopping Engine .....	19
Safety .....	3	Maintenance .....	19
- Decals .....	3	- Skill Levels .....	19
- International Symbols .....	4	- Maintenance Intervals .....	20
- Equipment .....	4	- Air Filter .....	21
- Fuel .....	5	- Fuel Filter .....	21
- Personal Condition and Safety Equipment .....	6	- Spark Plug .....	22
- Safe Operation .....	7	- Cooling System Cleaning .....	22
- Extended Operation/Extreme Conditions .....	8	- Exhaust System .....	23
Description .....	9	- Carburetor Adjustment .....	24
- Contents .....	9	- Lubrication .....	25
- Emission Control .....	9	Troubleshooting .....	26
Specifications .....	12	Storage .....	27
- ECHO Approved Optional Attachments .....	13	Servicing Information .....	28
- Recommended Optional Attachments .....	13	- Parts .....	28
Assembly .....	13	- Service .....	28
- Power Head Shaft/Attachment Lower		- ECHO Consumer Product Support .....	28
Shaft Assembly .....	13	- Warranty Card .....	28
- Front Handle Adjustment .....	14	- Additional or Replacement Manuals .....	28
Pre-Operation .....	14	- Manual Ordering Instructions .....	28
- Fuel .....	14		
- Equipment Check .....	16		
- Determine Operation Area .....	16		
Operation .....	17		

Specifications, descriptions and illustrative material in this literature are as accurate as known at the time of publication, but are subject to change without notice. Illustrations may include optional equipment and accessories, and may not include all standard equipment.

## MANUAL SAFETY SYMBOLS AND IMPORTANT INFORMATION

Throughout this manual and on the product itself, you will find safety alerts and helpful, information messages preceded by symbols or key words. The following is an explanation of those symbols and key words and what they mean to you.



This symbol accompanied by the words **WARNING** and **DANGER** calls attention to an act or condition that can lead to serious personal injury to operator and bystanders.



The circle with the slash symbol means whatever is shown within the circle is prohibited.



**IMPORTANT**



**NOTE**

### IMPORTANT

The enclosed message provides information necessary for the protection of the unit.

### NOTE

This enclosed message provides tips for use, care and maintenance of the unit.

## SAFETY

### DECALS

Locate these safety decals on your unit. The complete unit illustration, found in the "DESCRIPTION" section, will help you locate them. Make sure the decals are legible and that you understand and follow the instructions on them. If a decal cannot be read, a new one can be ordered from your ECHO dealer. See PARTS ORDERING instructions for specific information.

#### *Shaft Decal*

#### *Spanish Decal*

#### *English Translation*



89022809560

### ADVERTENCIA PELIGRO

Esta unidad puede ser peligrosa y producir lesiones personales graves si no se usa en forma adecuada. Para reducir el riesgo de lesionarse, los operadores, los ayudantes y los espectadores deben leer y comprender el Manual Del Operador y los Manuales De Seguridad que se entregan escritos en español.

### WARNING DANGER

This unit can be dangerous and cause serious injury if improperly used. To reduce injury risk to operator, helpers and bystanders, read and understand the Operator's and Safety Manuals, which are provided in Spanish.

## INTERNATIONAL SYMBOLS

Symbol form/shape	Symbol description/application	Symbol form/shape	Symbol description/application
	Read and understand Operator's Manual.		Fuel and oil mixture
	Wear eyes, ears and head protection		Finger Severing
	Hot Surface		Wear hand protection. Use two handed.
	Safety/Alert		DO NOT smoke near fuel.
	Avoid all power lines. This unit is not insulated against electrical current.		Do not operate closer than 15 m (50 ft.) from electrical hazards.
	Keep bystanders at least 15 m (50 ft.) away.		Plan retreat path from falling objects.

Symbol form/shape	Symbol description/application	Symbol form/shape	Symbol description/application
	DO NOT allow flames or sparks near fuel.		Wear slip resistant foot wear.
	Engine choke control.		Ignition ON/OFF
	Emergency stop		Primer bulb
	Chain lubrication		Carburetor adjustment - High speed mixture
	Carburetor adjustment - Low speed mixture		Carburetor adjustment - Idle speed

## EQUIPMENT

### WARNING DANGER

- Use only ECHO approved attachments for Pro Attachment Series models. Serious injury may result from the use of a non approved attachment combination. Read and comply with all safety instructions listed in this manual and attachment manual.
- ECHO, INC. will not be responsible for the failure of cutting devices, attachments or accessories which have not been tested and approved by ECHO for use with this Pro Attachment Series.

Before operation a complete check of the unit must be performed;

- Check unit for loose/missing nuts, bolts and screws. Tighten and/or replace as needed.
- Inspect fuel lines, tank and area around carburetor for fuel leaks. DO NOT operate unit if leaks are found.
- Inspect guards for damage and ensure that they are securely in place. Replace if guard is damaged or missing.
- Check that the attachment is firmly attached and in safe operating condition.



### Spark Arrestor - Catalytic Muffler / Muffler

- The muffler or catalytic muffler controls the exhaust noise and emissions. The spark arrestor screen prevents hot, glowing particles of carbon from leaving the muffler. Make sure the spark arrestor screen is in good repair and properly seated in the muffler. Keep exhaust area clear of flammable debris. Avoid contact during and immediately after operation.

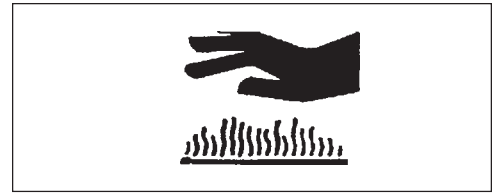

### FUEL

**WARNING**  **DANGER**

Fuel is **VERY** flammable. Use extreme care when mixing, storing or handling, otherwise serious personal injury may result.

- Use an approved fuel container.
- DO NOT smoke near fuel.
- DO NOT allow flames or sparks near fuel.
- Fuel tanks/cans may be under pressure. Always loosen fuel caps slowly allowing pressure to equalize.
- NEVER refuel a unit when the engine is HOT!
- NEVER refuel a unit with the engine running.
- DO NOT fill fuel tanks indoors. ALWAYS fill fuel tanks outdoors over bare ground.
- Securely tighten fuel cap after refueling.
- Inspect for fuel leakage. If fuel leakage is found, do not start or operate unit until leakage is repaired.



**IMPORTANT**

Spilled fuel is a leading cause of hydrocarbon emissions. Some states may require the use of automatic fuel shut-off containers to reduce fuel spillage. Contact your ECHO dealer for ordering information.



### After Refueling;

- Wipe any spilled fuel from the unit.
- Move at least 3 m (10 ft.) from refueling location before starting.

### After Use;

- DO NOT store a unit with fuel in its tank. Leaks can occur. Return unused fuel to an approved fuel storage container.

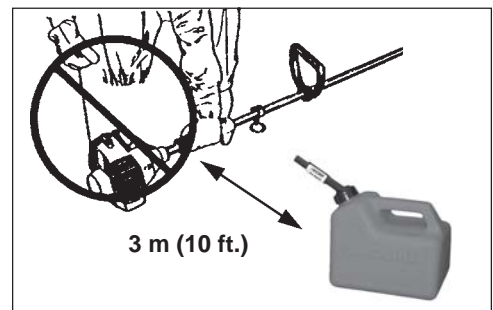

**PERSONAL CONDITION AND SAFETY EQUIPMENT****WARNING**  **DANGER**

Pro Attachment Series users risk injury to themselves and others if the Pro Attachment Series unit is used improperly and or safety precautions are not followed. Proper clothing and safety gear must be worn when operating a Pro Attachment Series unit.

***Physical Condition*** —

Your judgment and physical dexterity may not be good:

- if you are tired or sick,
- if you are taking medication,
- if you have taken alcohol or drugs.

Operate unit only if you are physically and mentally well.

***Eye Protection*** —

Wear eye protection that meets ANSI Z87.1 or CE requirements whenever you operate the unit.

***Hand Protection*** —

Wear no-slip, heavy duty work gloves to improve your grip on the unit handles. Gloves also reduce the transmission of machine vibration to your hands.

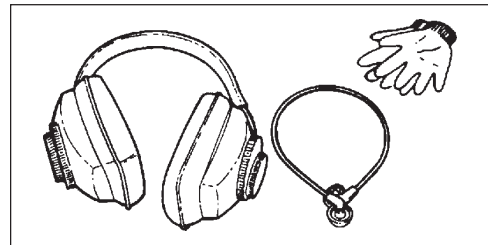
***Hearing Protection*** —

Wear hearing protection. ECHO recommends wearing hearing protection whenever unit is used.

***Proper Clothing*** —

Wear snug fitting, durable clothing;

- Pants should have long legs, shirts with long sleeves.
- **DONOT WEAR SHORTS,**
- **DONOT WEAR TIES, SCARVES, JEWELRY.**

Wear sturdy work shoes with non-skid soles;

- **DONOT WEAR OPENTOE SHOES,**
- **DONOT OPERATE UNIT BAREFOOTED.**

***Hot Humid Weather*** —

Heavy protective clothing can increase operator fatigue which may lead to heat stroke. Schedule heavy work for early morning or late afternoon hours when temperatures are cooler.

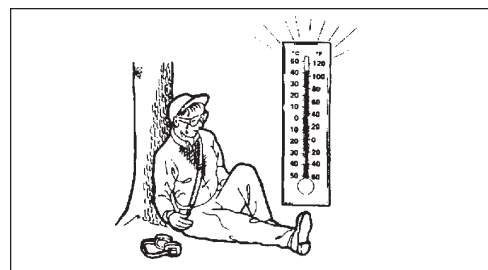

## SAFE OPERATION

### *Determine Operation Area*

- Provide all operators of this equipment with the Operator's Manuals and instructions for safe operation.
- Review the area where you will be operating. Look for hazards that could contribute to unsafe conditions.
- Spectators and fellow workers must be warned, and children and animals prevented from coming nearer than specified in the attachment operator's manual or safety manual. If unsure keep people and pets away 15 m (50 ft.).

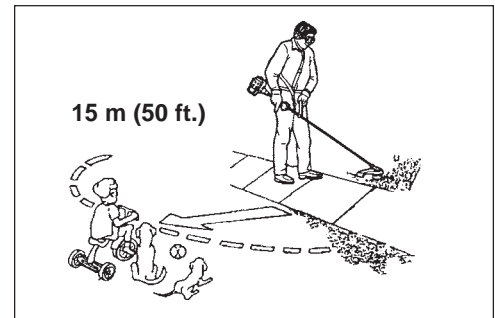

### *Operation*

#### Use Proper Clothing & Equipment

- Before starting the unit, equip yourself and any other person working within the specified Safety Zone provided in your attachment manual with the required Protective Equipment and clothing.

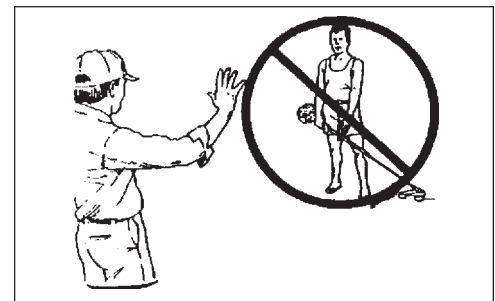

**WARNING**  **DANGER**

Do not operate this product indoors or in inadequately ventilated areas. Engine exhaust contains poisonous emissions and can cause serious injury or death.

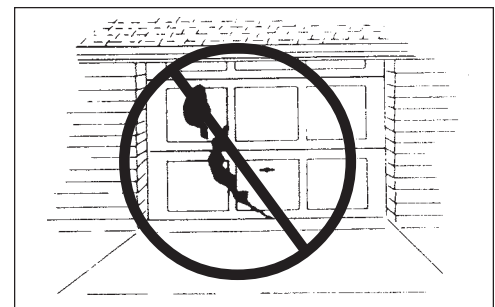

#### Avoid Hot Surfaces

- During operation, the drive shaft housing, attachment bearing housing and muffler cover area may become very hot, too hot to touch. Avoid contact during and immediately after operation. Always keep exhaust area clear of flammable debris. Allow the engine and muffler to completely cool before performing any maintenance activity.

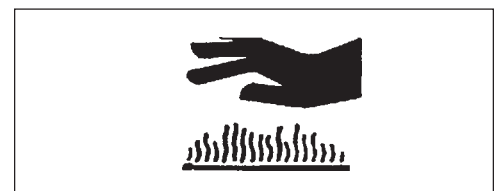

#### Keep A Firm Grip

- Hold the front and rear handles with both hands with thumbs and fingers encircling the handles



#### Keep A Solid Stance

- Maintain footing and balance at all times. Do not stand on slippery, uneven or unstable surfaces. Do not work in odd positions or on ladders. Do not over reach.

**EXTENDED OPERATION/EXTREME CONDITIONS*****Vibration and Cold --***

It is believed that a condition called Raynaud's Phenomenon, which affects the fingers of certain individuals may be brought about by exposure to vibration and cold. Exposure to vibration and cold may cause tingling and burning sensations followed by loss of color and numbness in the fingers. The following precautions are strongly recommended because the minimum exposure which might trigger the ailment is unknown.

- Keep your body warm, especially the head, neck, feet, ankles, hands and wrists.
- Maintain good blood circulation by performing vigorous arm exercises during frequent work breaks and also by not smoking.
- Limit the hours of operation. Try to fill each day with jobs where operating the trimmer or other hand-held power equipment is not required.
- If you experience discomfort, redness and swelling of the fingers followed by whitening and loss of feeling, consult your physician before further exposing yourself to cold and vibration.

***Repetitive Stress Injuries --***

It is believed that overusing the muscles and tendons of the fingers, hands, arms and shoulders may cause soreness, swelling, numbness, weakness and extreme pain in those areas. Certain repetitive hand activities may put you at a high risk for developing a Repetitive Stress Injury (RSI). An extreme RSI condition is Carpal Tunnel Syndrome (CTS), which could occur when your wrist swells and squeezes a vital nerve that runs through the area. Some believe that prolonged exposure to vibration may contribute to CTS. CTS can cause severe pain for months or even years.

To reduce the risk of RSI/CTS, do the following:

- Avoid using your wrist in a bent, extended or twisted position. Instead try to maintain a straight wrist position. Also, when grasping, use your whole hand, not just the thumb and index finger.
- Take periodic breaks to minimize repetition and rest your hands.
- Reduce the speed and force with which you do the repetitive movement.
- Do exercises to strengthen the hand and arm muscles.
- Immediately stop using all power equipment and consult a doctor if you feel tingling, numbness or pain in the fingers, hands, wrists or arms. The sooner RSI/CTS is diagnosed, the more likely permanent nerve and muscle damage can be prevented.

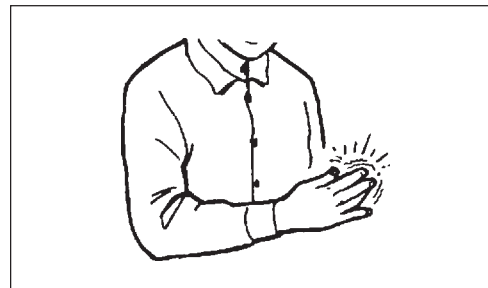
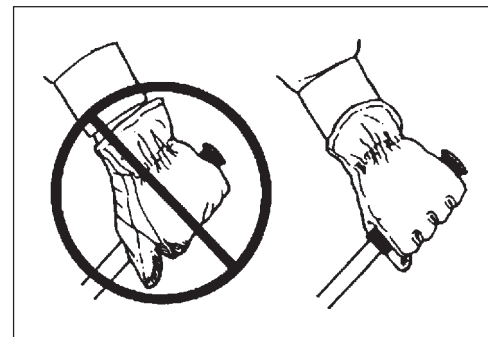
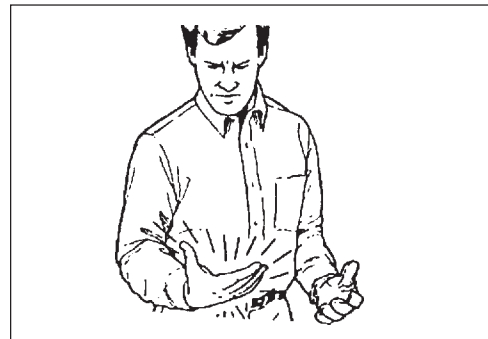
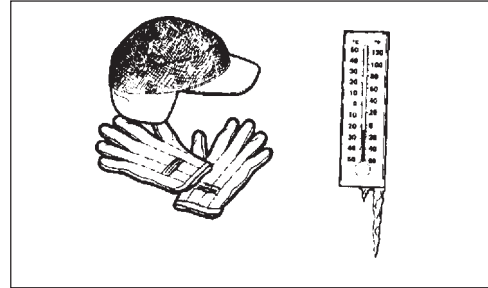



## DESCRIPTION

The ECHO product you purchased has been factory pre-assembled for your convenience. Due to packaging restrictions, other assembly may be necessary.

After opening the carton, check for damage. Immediately notify your retailer or ECHO Dealer of damaged or missing parts. Use the contents list to check for missing parts.

## CONTENTS

- 1 - Power Head w / Upper Drive Shaft Assembly
- 1 - Plastic Bag (co-pack)
  - 1, Operator's Manual
  - 1, Warranty Registration Card
  - 1, ECHO Emissions and Warranty Statement
  - 1, Safety Glasses
  - 1, 2-Stroke Oil Sample, 2.6 oz.

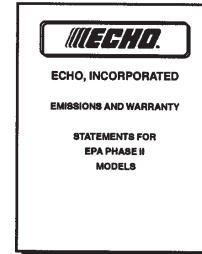
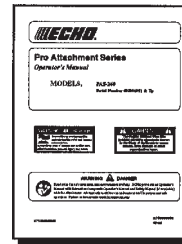

## EMISSION CONTROL

### EPA Phase II

The emission control system for these engines are EM (Engine Modification).

**IMPORTANT ENGINE INFORMATION**  
 ENGINE FAMILY: YEHXS.0254CA  
 DISPLACEMENT: 25.4 cc  
 THIS ENGINE MEETS U.S. EPA PHASE II EMISSION REGULATIONS FOR S.O.R.E. REFER TO OWNER'S MANUAL FOR MAINTENANCE SPECIFICATIONS AND ADJUSTMENTS.  
 EMISSION COMPLIANCE PERIOD : 300 HRS.



**KIORTZ CORP.**



**An Emission Control Label** is located on the engine. (This is an EXAMPLE ONLY, information on label varies by engine FAMILY).

### PRODUCT EMISSION DURABILITY

The 300 hour emission durability period is the time span selected by the manufacturer certifying the engine emissions output meets applicable EPA emissions regulations, provided that approved maintenance procedures are followed as listed in the Maintenance Section of this manual.

# 10 ECHO®

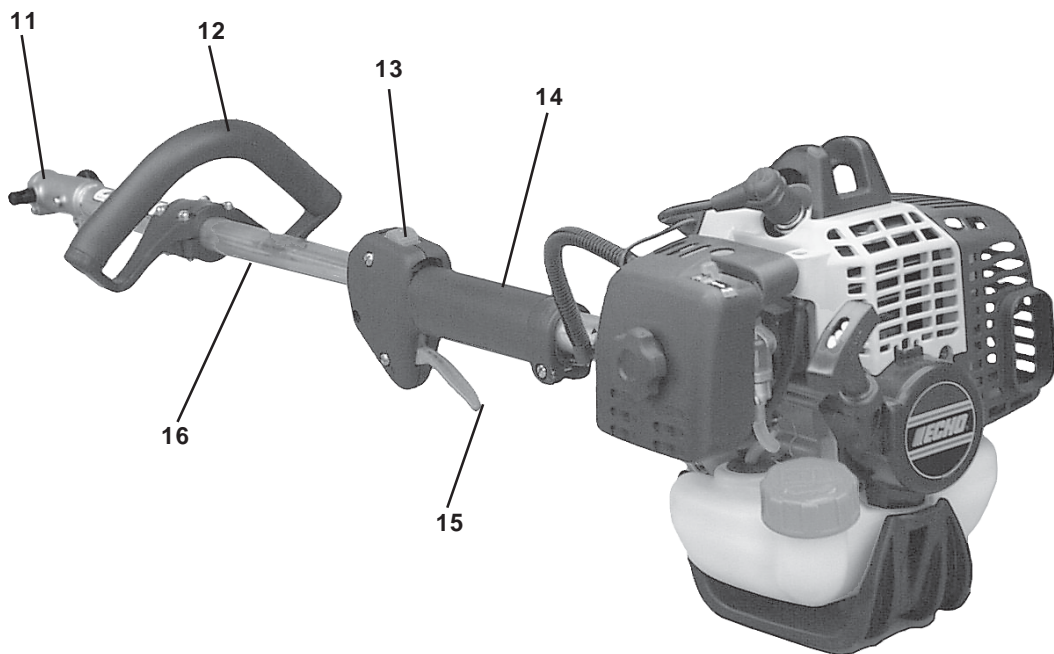
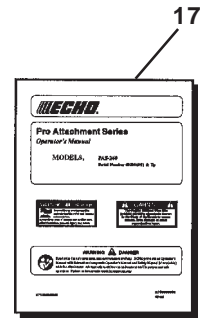
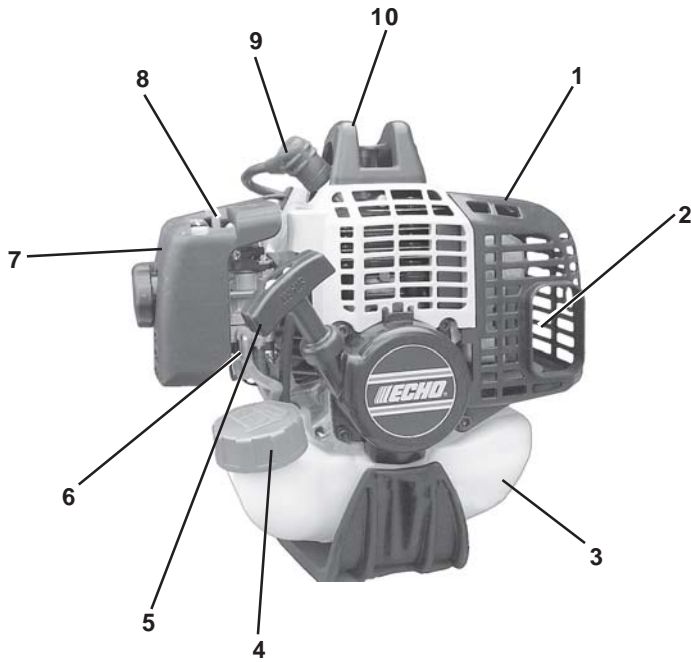

1. **POWER HEAD** - Includes the Engine, Clutch, Fuel System, Ignition System and Recoil Starter.
2. **MUFFLER, SPARK ARRESTOR** - The muffler controls the exhaust noise while the spark arrestor prevents hot, glowing particles of carbon from leaving the muffler where they could possibly start a fire.
3. **FUEL TANK** - Contains fuel and fuel filter.
4. **FUEL TANK CAP** - Covers and seals fuel tank opening.
5. **RECOIL STARTER HANDLE** - Pull handle slowly until recoil starter engages, then quickly and firmly. When engine starts, return handle slowly. **DO NOT** let handle snap back or damage to unit will occur.
6. **PRIMER BULB** - Pumping primer bulb before starting engine draws fresh fuel from the fuel tank priming the carburetor for starting. Pump primer bulb until fuel is visible and flows freely in the clear fuel tank return line. Pump bulb an additional 4 or 5 times.
7. **AIR CLEANER** - Contains replaceable filter element.
8. **CHOKE** - The choke control lever is located on the top of the air cleaner case. Move choke lever to "COLD START" to close choke for cold starting. Move choke lever to the "RUN" position to open choke.
9. **SPARK PLUG** - Provides spark to ignite fuel mixture.
10. **ARM REST** - Provides arm rest during operation and protects arm from the hot engine.
11. **DRIVE SHAFT COUPLER** - Includes Locator Pin and Clamping Knob.
12. **FRONT HANDLE** - The Front Handle is assembled to the Upper Drive Shaft assembly and must be positioned for proper cutting attitude and operator comfort.
13. **STOP SWITCH** - "SLIDE SWITCH" mounted on top of the Throttle Trigger Housing. Move switch FORWARD to RUN, BACK to STOP.
14. **GRIP** - Rear (right hand) handle.
15. **THROTTLE TRIGGER** - Spring loaded to return to idle when released. During acceleration, press trigger gradually for best operating technique.
16. **UPPER DRIVE SHAFT ASSEMBLY** - Includes the Rear (Right Hand) Handle Assembly, Front (Left Hand) Handle Assembly, Flexible Drive Cable, Drive Shaft Assembly Coupler and Power Head.
17. **OPERATOR'S MANUAL** - Included in plastic bag (co-pack). Read before operation and keep in a safe place for future reference, i.e., operation, maintenance, storage and specifications.

## SPECIFICATIONS

MODEL	PAS-260
Shaft Length	756 mm (29.8 in.)
Unit Length	1025 mm (40.4 in.)
Width	250 mm (9.84 in.)
Height	250 mm (9.84 in.)
Weight (dry)	4.1 kg (9.0 lb.)
Engine Type	Air cooled, two-stroke, single cylinder gasoline engine
Bore	34.0 mm (1.34 in.)
Stroke	28.0 mm (1.10 in.)
Displacement	25.4 cc (1.55 cu. in.)
Exhaust	Spark Arrestor Muffler
Carburetor	Walbro model WYJ w/purge pump
Ignition System	CDI (capacitor discharge ignition)
Spark Plug	NGK BPM-7Y Gap 0.65 mm (0.026 in.)
Fuel	Mixed (Gasoline and Two-stroke Oil)
Fuel/Oil Ratio	50:1 ECHO High Performance, two-stroke air cooled engine oil
Gasoline	89 Octane unleaded. DO NOT use fuel containing methyl alcohol, more than 10% ethyl alcohol or 15% MTBE.
Oil	50:1 ECHO High Performance, two-stroke air cooled engine oil
Fuel Tank Capacity	0.58 lit. (19.6 US fl. oz.)
Starter System	Automatic Rewind Starter
Clutch	Centrifugal Type
Drive Shaft	6.35 mm (1/4 in.) flexible shaft
Idle Speed	2400 - 3000
Wide Open Throttle Speed (W.O.T.) RPM	9000 - 12000

## ECHO APPROVED OPTIONAL ATTACHMENTS

### WARNING DANGER

- Use only ECHO approved attachments for Pro Attachment Series models. Serious injury may result from the use of non approved attachment combinations. Read and comply with all safety instructions listed in this manual and attachment manual.
- ECHO, INC. will not be responsible for the failure of cutting devices, attachments or accessories which have not been tested and approved by ECHO for use with this Pro Attachment Series unit.

## RECOMMENDED OPTIONAL ATTACHMENTS

• PAS Edger	Model 99944200470	• PAS Pro Sweep™	Model 99944200550
• PAS Cultivator	Model 99944200510	• PAS Pro Thatch™	Model 99944200560
• PAS Trimmer	Model 99944200540	• PAS Articulating Hedge Clipper	Model 99944200590
• PAS Hedge Clipper	Model 99944200480	• PAS Rapid Loader™	Model 99944200610
• PAS Power Pruner™	Model 99944200530	• PAS Brush Cutter	Model 99944200600

## ASSEMBLY

### POWER HEAD SHAFT/ATTACHMENT LOWER SHAFT ASSEMBLY

*Tools Required:* None

*Parts Required:* Power Head Shaft, Attachment Lower Shaft Assembly

1. Set Power Head/Shaft Assembly on a level surface.
2. Pull locator pin (A) and rotate counter clockwise 1/4 turn to lock out position.
3. Carefully fit attachment lower drive shaft assembly into coupler (B) to decal assembly line (C), making sure that the inner lower drive shaft engages into the upper drive shaft mount.

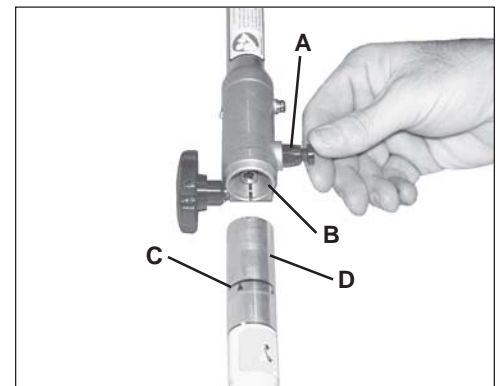

#### NOTE

Lower bearing housing and head assembly must be in line with the engine.

4. Rotate locator pin (A) 1/4 turn clockwise to engage lower shaft hole (D). Insure locator pin is fully engaged by gently twisting lower drive shaft. Locator pin should snap flush in coupler. Full engagement will prevent further shaft rotation.
5. Secure lower shaft assembly to coupler by tightening clamping knob (E).

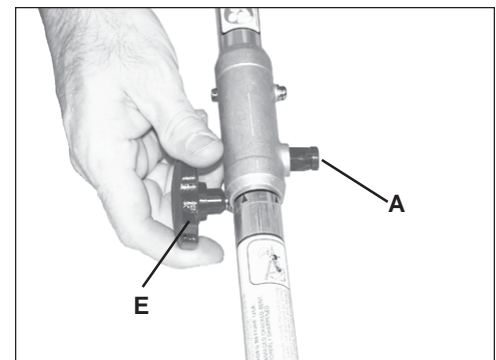

## FRONT HANDLE ADJUSTMENT

*Tools Required:* Screwdriver.

*Parts Required:* None

1. Stand in a comfortable operating position with attachment assembled and move front handle for comfortable operation. Tighten handle screws.



## PRE - OPERATION

### FUEL

#### Fuel Requirements

**Gasoline** - Use 89 Octane  $\frac{R+M}{2}$  (mid grade or higher) gasoline known to be good quality. Gasoline may contain up to 15% MTBE (methyl tertiary-butyl ether). Gasohol containing methyl (wood) alcohol is **NOT** approved.

**Two Stroke Oil** - A two-stroke engine oil meeting ISO-L-EGD (ISO/CD 13738) and J.A.S.O. FC Standards, must be used. Echo brand Premium 50:1 oil meets these standards. Engine problems due to inadequate lubrication caused by failure to use an ISO-L-EGD and J.A.S.O. FC certified oil, such as Echo Premium 50:1 Two-stroke Oil, will void the two-stroke engine warranty. (Emission related parts only are covered for two years, regardless of two-stroke oil used, per the statement listed in the EPA Phase II Emission Defect Warranty Explanation.)

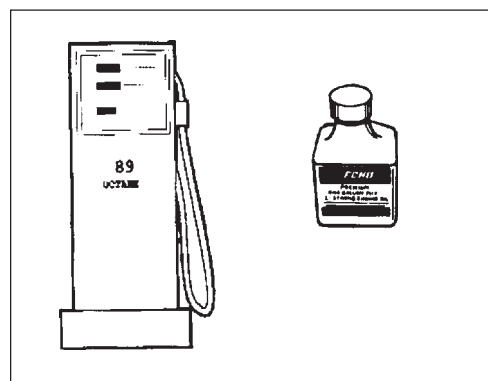

#### **IMPORTANT**

Echo Premium 2-Stroke Oil may be mixed at 50:1 ratio for application in all Echo engines sold in the past regardless of ratio specified in those manuals.

**Mixing Instructions**

1. Fill an approved fuel container with half of the required amount of gasoline.
2. Add 2-stroke oil to gasoline.
3. Close container and shake to mix oil with gasoline.
4. Add remaining gasoline and remix.
5. Install fuel container cap and wipe any spilled fuel from container and surrounding area.

**Handling Fuel**

**WARNING**  **DANGER**

Fuel is **VERY** flammable. Use extreme care when mixing, storing or handling or serious personal injury may result.

- Use an approved fuel container.
- **DO NOT** smoke near fuel.
- **DO NOT** allow flames or sparks near fuel.
- Fuel tanks/cans may be under pressure. Always loosen fuel caps slowly allowing pressure to equalize.
- **NEVER** refuel a unit when the engine is **HOT!**
- **NEVER** refuel a unit with the engine running.
- **DO NOT** fill fuel tanks indoors. **ALWAYS** fill fuel tanks out doors over bare ground.
- Securely tighten fuel cap after refueling.
- Inspect for fuel leakage. If fuel leakage is found, do not start or operate unit until leakage is repaired.

**IMPORTANT**

Spilled fuel is a leading cause of hydrocarbon emissions. Some states may require the use of automatic fuel shut-off containers to reduce fuel spillage. Contact your ECHO dealer for ordering information.

**After Refueling –**

- Wipe any spilled fuel from the unit.
- Move at least 3 m (10 ft.) from refueling location before starting.

**After use –**

- **DO NOT** store a unit with fuel in its tank. Leaks can occur. Return unused fuel to an approved fuel storage container.

**Storage –**

Fuel storage laws vary by locality. Contact your local government for the laws affecting your area. As a precaution, store fuel in an approved, air tight container. Store in a well ventilated, unoccupied building, away from sparks and flames. Do not store fuel longer than 30 days.

**IMPORTANT**

Stored fuel ages. Do not mix more fuel than you expect to use in thirty (30) days, ninety (90) days when a fuel stabilizer is added.

**IMPORTANT**

Stored two-stroke fuel may separate. **ALWAYS** shake fuel container thoroughly before each use.

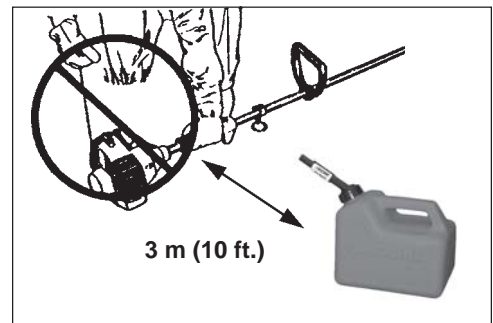

S	M	T	W	T	F	S
1	2	3	4	5	6	7
8	9	10	11	12	13	14
15	16	17	18	19	20	21
22	23	24	25	26	27	28
29	30	31				

## EQUIPMENT CHECK

Before operation a complete check of the unit and attachment must be performed;

- Check for loose/missing nuts, bolts and screws. Tighten and/or replace as needed.
- Inspect fuel lines, tank and area around carburetor for fuel leaks. DO NOT operate unit if leaks are found.
- Check that the attachment is firmly attached and in safe operating condition.
- Check that front handle is adjusted for safe, comfortable operation. See Assembly for proper adjustment.



## DETERMINE OPERATION AREA

### WARNING DANGER

Inspect starting area for hazards such as rocks, glass, debris etc. which could be thrown by the cutting attachment when starting. Keep helpers and bystanders at least 15 m (50 ft) from starting area, otherwise serious personal injury may result.

- Spectators and fellow workers must be warned, and children and animals prevented from coming nearer than specified in the attachment Operator's Manual or Safety Manual. If unsure keep people and pets away 15 m (50 ft.).

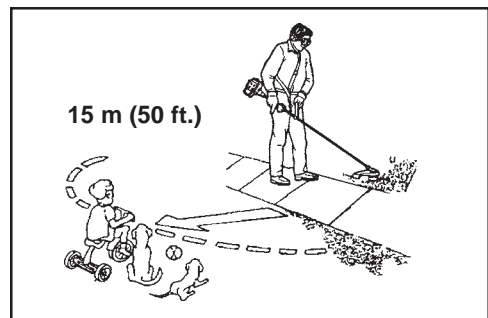



## OPERATION

- Provide all operators of this equipment with the Operator's Manuals and instructions for safe operation.
- Before starting the unit, equip yourself and any other person working within the specified Safety Zone provided in your attachment manual with the required Protective Equipment and clothing.
- During operation, the drive shaft housing, attachment bearing housing and muffler cover area may become very hot, too hot to touch. Avoid contact during and immediately after operation. Always keep exhaust area clear of flammable debris. Allow the engine and muffler to completely cool before performing any maintenance activity.

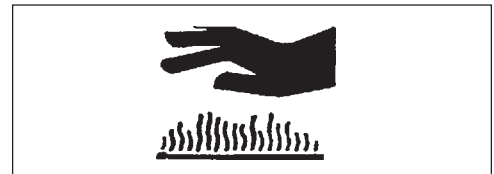
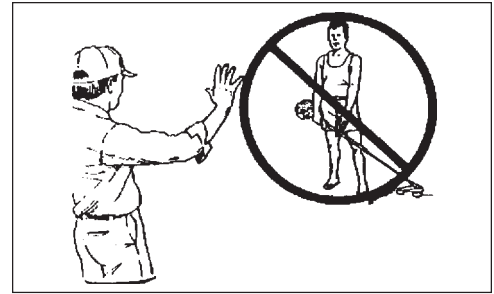

## STARTING COLD ENGINE

### WARNING DANGER

The cutting attachment should not move at idle. If cutting attachment moves, readjust carburetor according to "Carburetor Adjustment" instructions in this manual or see your ECHO Dealer, otherwise serious personal injury may result.

1. Stop Switch - Start/Run.  
Move stop switch button/lever (A) away from the STOP position.
2. Close Choke - Cold Start.  
Move choke lever (B) to Cold Start Position.
3. Primer - Pump Bulb.  
Pump primer bulb (C) until fuel is visible and flows freely in the clear fuel tank return line. Pump bulb an additional 4 or 5 times.

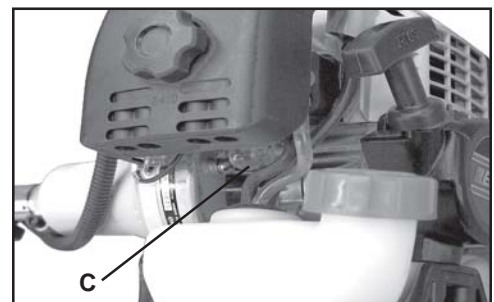
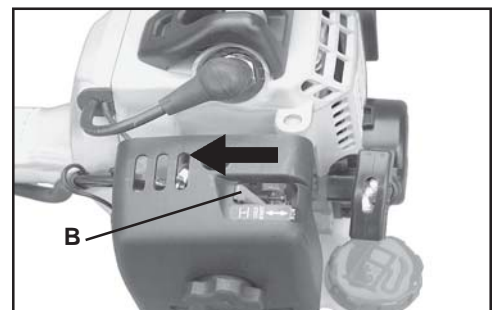
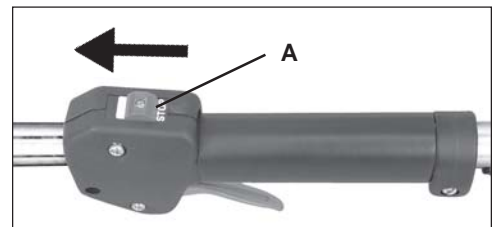

4. *Start - Pull Rope.*  
Lay the unit on a flat clear area and pull the recoil starter handle (E) until engine fires.
5. *Open Choke - Run.*  
Move the choke lever to the OPEN-RUN position. Restart engine if necessary and allow to warm up running at idle for several minutes.

**NOTE**

If engine does not start with choke in "RUN" position after 5 pulls, repeat instructions.

6. After engine warm up, gradually depress throttle trigger to increase engine RPM to operating speed.

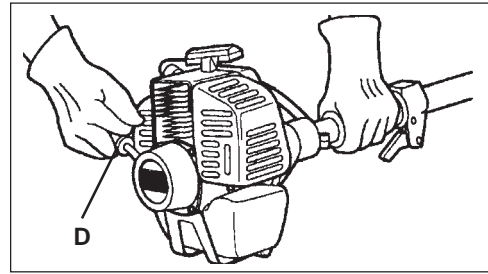

## STARTING WARM ENGINE

**WARNING**  **DANGER**

The cutting attachment should not move at idle. If cutting attachment moves, readjust carburetor according to "Carburetor Adjustment" instructions in this manual or see your ECHO Dealer, otherwise serious personal injury may result.

1. *Stop Switch - Start/Run.*  
Move stop switch button/lever (A) away from the STOP position.
2. *Primer - Pump Bulb.*  
Pump primer bulb (C) until fuel is visible and flows freely in the clear fuel tank return line. Pump bulb an additional 4 or 5 times.
3. *Starting.*  
Lay unit on a flat, clear area and pull recoil starter handle/rope (D) until engine fires.

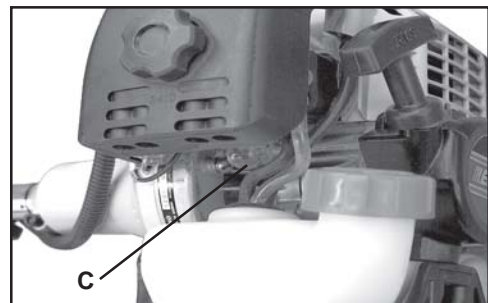
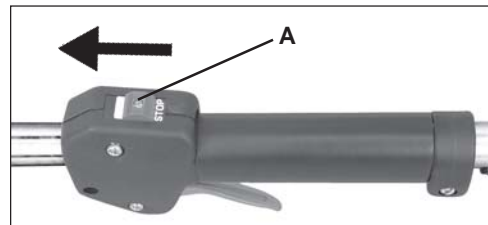

**NOTE**

If engine does not start after 5 pulls, use Cold Start Procedure.

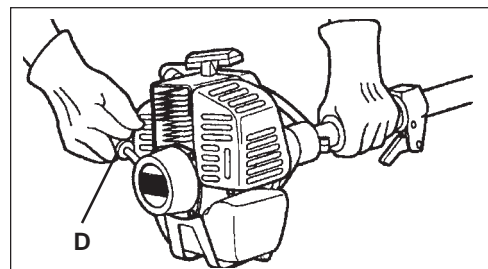

## STOPPING ENGINE

1. *Release Throttle.* Allow engine to idle for a minute.
2. *Stop Switch - Stop.* Move stop switch button/lever (A) to STOP position.

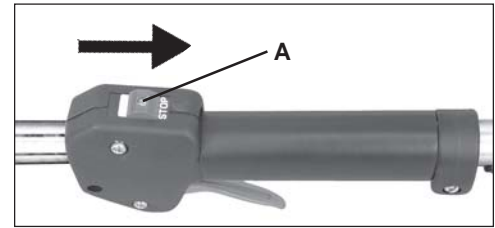

### WARNING DANGER

If engine does not stop when stop switch is moved to STOP position, close choke - COLD START position - to stall engine. Have your ECHO dealer repair stop switch before using unit again.

### NOTE

Refer to the attachment Operator's Manual and Safety Manual (if included) for proper and safe operating techniques.

## MAINTENANCE

Your ECHO unit is designed to provide many hours of trouble free service. Regular scheduled maintenance will help your unit achieve that goal. If you are unsure or are not equipped with the necessary tools, you may want to take your unit to an ECHO Service Dealer for maintenance. To help you decide whether you want to DO-IT-YOURSELF or have the ECHO Dealer do it, each maintenance task has been graded. If the task is not listed, see your ECHO Dealer for repairs.

## SKILL LEVELS

- Level 1**= Easy to do. Most required tools come with unit.
- Level 2**= Moderate difficulty. Some specialized tools may be required.
- Level 3**= Experience required. Specialized tools are required. ECHO recommends that the unit be returned to your ECHO dealer for service.

ECHO offers **REPOWER™** Maintenance Kits and Parts to make your maintenance job easier. Below each task heading are listed the various part numbers required for that task. See your ECHO dealer for these parts.

## MAINTENANCE INTERVALS

COMPONENT/ SYSTEM	MAINTENANCE PROCEDURE	REQ'D SKILL LEVEL	DAILY OR BEFORE USE	EVERY REFUEL	3 MONTHS OR 90 HOURS	6 MONTHS OR 270 HOURS	YEARLY 600 HOURS
<b>Recommended Echo Dealer Maintenance Procedures</b>							
Cylinder Exhaust Port	Inspect/Clean/Decarbon	<b>3</b>			<b>I / C</b>		
<b>Do-It-Yourself Maintenance Procedures</b>							
Air Filter	Inspect/Clean/Replace	<b>1</b>	<b>I / C</b>		<b>R*</b>		
Choke	Inspect/Clean	<b>2</b>	<b>I / C</b>				
Fuel Filter	Inspect/Replace	<b>1</b>			<b>I</b>		<b>I / R *</b>
Fuel System, leaks	Inspect/Replace	<b>1</b>	<b>I *</b>	<b>I</b>	<b>I</b>		
Cooling System	Inspect/Clean	<b>2</b>	<b>I / C</b>				
Muffler Spark Arrestor	Inspect/Replace	<b>2</b>			<b>I / R *</b>		
Drive Shaft	Grease	<b>2</b>			<b>I (1)</b>		
Recoil Starter Rope	Inspect/Clean	<b>1</b>	<b>I / C *</b>				
Spark Plug	Inspect/Clean	<b>2</b>			<b>I / C</b>	<b>R *</b>	
Screws/Nuts/Bolts	Inspect/Tighten/Replace	<b>1</b>	<b>I / R *</b>				

**MAINTENANCE PROCEDURE LETTER CODES: I = INSPECT, R = REPLACE, C = CLEAN**

**IMPORTANT NOTE** - Time intervals shown are maximum. Actual use and your experience will determine the frequency of required maintenance.

**MAINTENANCE PROCEDURE NOTES:**

(1) Apply ECHO® LUBE™ every 25 hours of use.

\* All recommendations to replace are based on the finding of damage or wear during inspection..

## AIR FILTER

### Level 1.

*Tools required:* 25 or 50 mm (1 or 2 in.) medium bristle paint brush

*Parts required:* 90030 REPOWER™ Air and Fuel Filter Kit

1. Close choke (Cold Start Position). This prevents dirt from entering the carburetor throat when the air filter is removed. Brush accumulated dirt from the air cleaner area.
2. Remove the air cleaner cover. Clean and inspect the element for damage. If element is fuel soaked and very dirty, replace.
3. If element can be cleaned and reused, be certain it:
  - still fits the cavity in the air cleaner cover.
  - is installed with the original side out.

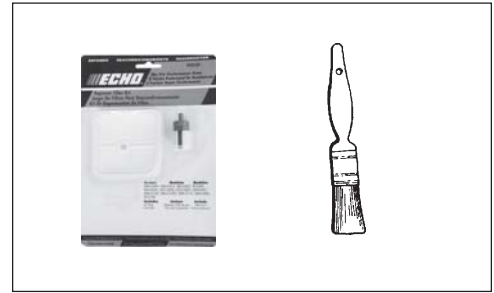

## FUEL FILTER

### Level 1.

*Tools required:* 203-254 mm (8-10 in.) length of wire with one end bent into a hook, Clean rag, funnel, an approved fuel container,

*Parts required:* 90030 REPOWER™ Air and Fuel Filter Kit

**WARNING**  **DANGER**

Fuel is **VERY** flammable. Use extreme care when mixing, storing or handling, otherwise serious personal injury may result.

1. Use a clean rag to remove loose dirt from around fuel cap and empty fuel tank.
2. Use the “fuel line hook” to pull the fuel line and filter from the tank.
3. Remove the filter from the line and install the new filter.

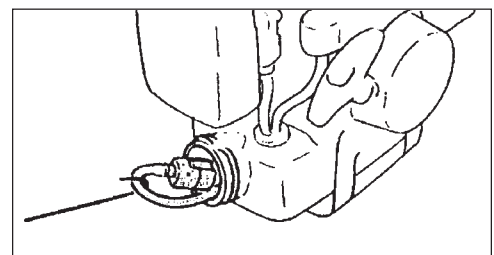
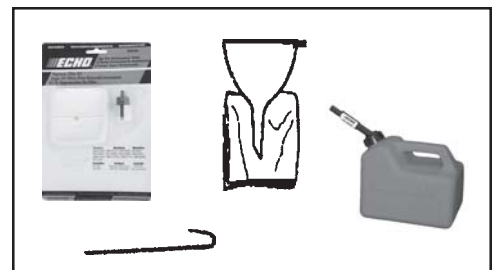

## WARNING DANGER

Do not perform maintenance on the muffler until engine and muffler are completely cool, otherwise serious personal injury may occur.

## SPARK PLUG

### Level 2.

*Tools required:* Screwdriver, Feeler gauge (preferably a wire gauge), Soft metal brush.

*Parts Required:* 90065 REPOWER TUNE-UP KIT

1. Remove spark plug and check for fouling, worn and rounded center electrode.
2. Clean the plug or replace with a new one. DO NOT sand blast to clean. Remaining sand will damage engine.
3. Adjust spark plug gap by bending outer electrode.
4. Tighten spark plug to 145-155 kg/cm (125-135 in. lb.).

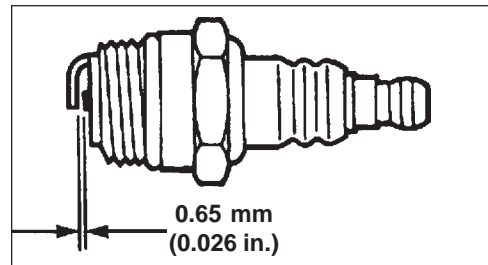
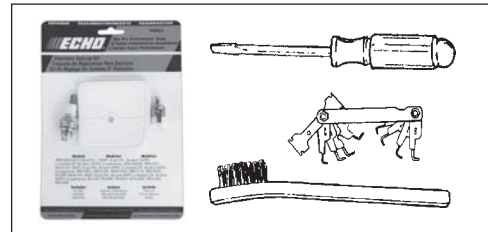

## COOLING SYSTEM CLEANING

### Level 2.

*Tools required:* 25 or 50 mm (1 or 2 in.) medium bristle paint brush, Cross-Head Screwdriver, 4 mm Hex Wrench

*Parts Required:* None if you are careful.

### IMPORTANT

To maintain proper engine operating temperatures, cooling air must pass freely through the cylinder fin area. This flow of air carries combustion heat away from the engine.

Overheating and engine seizure can occur when:

- Air intakes are blocked, preventing cooling air from reaching the cylinder.
- Dust and grass build up on the outside of the cylinder. This build up insulates the engine and prevents the heat from leaving.

Removal of cooling passage blockages or cleaning of cooling fins is considered "Normal Maintenance". Any failure attributed to lack of maintenance is not warranted.

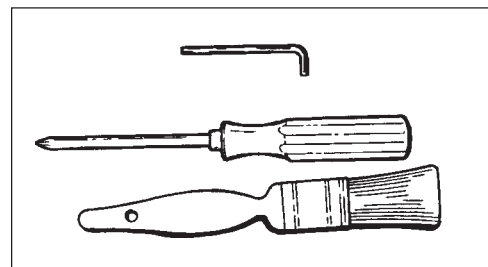

1. Remove spark plug lead.
2. Remove two (2) muffler cover screws and muffler cover (A).
3. Remove screw and arm rest (B).
4. Remove engine cover (C).

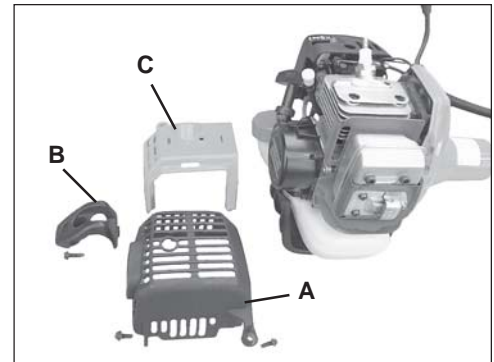

**IMPORTANT**

DO NOT use a metal scraper to remove dirt from the cylinder fins.

5. Use brush to remove dirt from the cylinder fins.
6. Remove grass and leaves from the grid between the recoil starter and fuel tank.

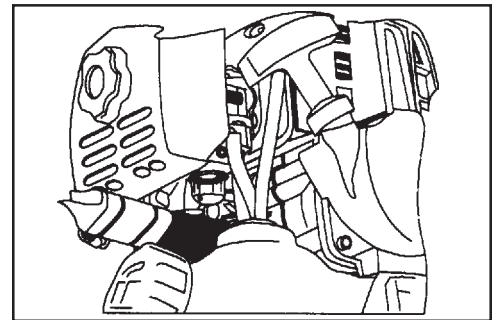

**EXHAUST SYSTEM**

*Spark Arrestor Screen*

**Level 2.**

*Tools required:* Cross-Head Screwdriver, Soft metal brush, 4 mm Hex Wrench.

*Parts Required:* Screen P/N 14586251030

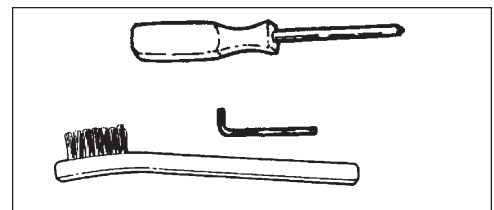

1. Remove muffler cover (A).
2. Place piston at Top Dead Center (TDC) to prevent carbon/dirt from entering cylinder.
3. Remove spark arrestor screen cover (B), muffler gasket (C), screen gasket (D) and screen (E) from muffler body.
4. Clean carbon deposits from screen and muffler components.
5. Replace screen if it is cracked, plugged or has holes burned through.
6. Assemble components in reverse order.

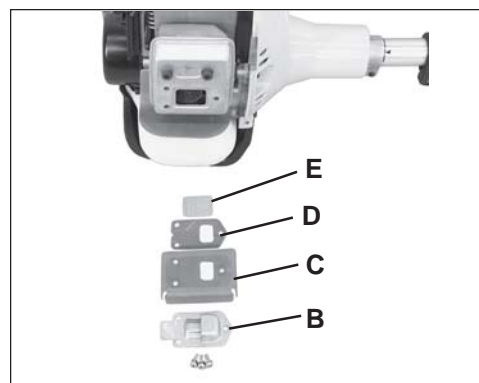

## Cylinder Exhaust Port

### Level 3.

#### IMPORTANT

The cylinder exhaust port must be inspected and cleaned of excess carbon every 3 months or 90 hours of operation in order to maintain this engine within the emissions durability period. ECHO strongly recommends that you return your unit to your ECHO dealer for this important maintenance service.

## CARBURETOR ADJUSTMENT

### Engine Break-In

New engines must be operated a minimum duration of two tanks of fuel break-in before carburetor adjustments can be made. During the break-in period your engine performance will increase and exhaust emissions will stabilize. Idle speed can be adjusted as required.

### High Altitude Adjustment

High altitude adjustment is not required for proper operation of this engine.

### Level 2.

*Tools required:* Slotted Screwdriver, Tachometer (ECHO P/N 99051130017).

*Parts required:* None.

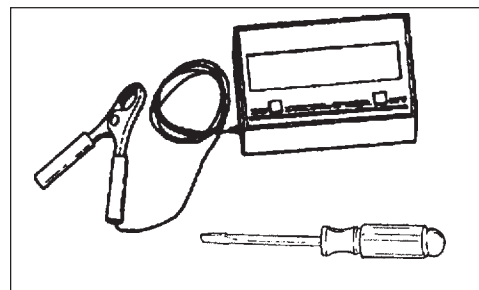



**NOTE**

Every unit is run at the factory and the carburetor is set in compliance with EPA Phase II Emission Regulations. This carburetor does not have acceleration and high speed adjustment needles.

1. Check idle speed and reset if necessary. If a tachometer is available, idle speed screw (A) should be set to the specifications found on page 12 "Specifications" of this manual. Turn idle screw (A) clockwise to increase idle speed; counter clockwise to decrease idle speed.



**WARNING**  **DANGER**

When carburetor adjustment is completed, the attachment should not rotate at idle, otherwise serious personal injury may result.

**LUBRICATION**

**Level 1.**

*Tools required:* Screwdriver, Clean Rag

*Parts Required:* Echo Lube™ 8 oz. (P/N 91014) or Lithium Base Grease.

**Drive Shaft Upper**

**IMPORTANT**

The drive shaft must be lubricated with high temperature automotive grease every 25 hours of operation, otherwise drive shaft assembly overheating and failure can result.

1. Loosen clamping knob (A).
2. Pull locator pin (B) and rotate 1/4 turn counter clockwise to lockout position.
3. Remove attachment.
4. Remove coupler from upper drive shaft assembly by loosening clamping screw (C) and removing set screw (D).
5. Remove upper flex cable, wipe clean and apply a thin coating of 1/2 oz. (15ml) of grease.
6. Install cable. Make sure that the flex cable engages into the clutch mount. Install coupler engaging coupler adapter onto flex cable end.
7. Install set screw (D) and tighten clamping screw (C).

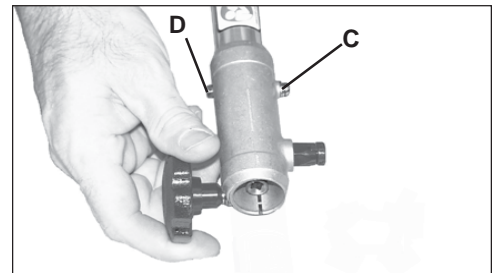
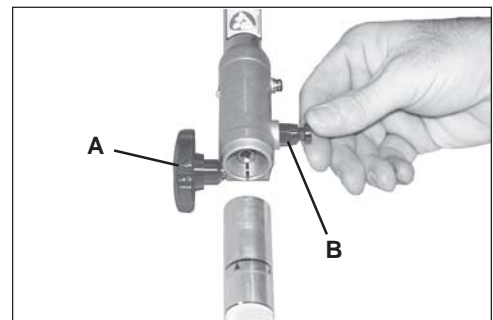
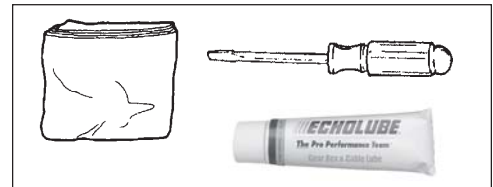

## TROUBLESHOOTING

Problem					
Engine -- starts hard					
Engine -- does not start			<b>Cause</b>	<b>Remedy</b>	
Engine Cranks	Fuel at carburetor	No fuel at carburetor	Fuel strainer clogged Fuel line clogged Carburetor	Clean Clean See your ECHO dealer	
	↓	Fuel at cylinder	No fuel at cylinder	Carburetor	See your ECHO dealer
	↓		Muffler wet with fuel	Fuel Mixture is too rich	Open choke Clean/replace air filter Adjust carburetor See your ECHO dealer
	↓	Spark at end of plug wire	No spark at end of plug wire	Stop switch off Electrical problem Interlock switch	Turn switch on See your ECHO dealer See your ECHO dealer
	↓	Spark at plug	No spark at plug	Spark gap incorrect Covered with carbon Fouled with fuel Spark plug defective	Adjust 0.65mm (0.026in.) Clean or replace Clean or replace Replace plug
Engine does not crank			Internal engine problem	See your ECHO dealer	
Engine runs	Dies or accelerates poorly		Air filter dirty Fuel filter dirty Fuel vent plugged Spark plug Carburetor Cooling system plugged Spark arrestor screen plugged	Clean or replace Replace Replace Clean and adjust/replace Adjust Clean Clean	

### WARNING DANGER

Fuel vapors are **extremely** flammable and may cause fire and/or explosion. **Never** test for ignition spark near an open spark plug opening, otherwise serious personal injury may result.

## STORAGE

### *Long Term Storage (over 30 days)*

**WARNING**  **DANGER**

During operation the muffler or catalytic muffler and surrounding cover become hot. Always keep exhaust area clear of flammable debris during transportation or when storing, otherwise serious property damage or personal injury may result.

Do not store your unit for a prolonged period of time (30 days or longer) without performing protective storage maintenance which includes the following:

1. Store unit in a dry, dust free place, out of the reach of children with drive shaft housing in an upright or horizontal position to prevent grease leakage.

**WARNING**  **DANGER**

Do not store in enclosure where fuel fumes may accumulate or reach an open flame or spark.

2. Place the stop switch (A) in the "OFF" position.
3. Remove accumulation of grease, oil, dirt and debris from exterior of unit.
4. Perform all periodic lubrication and services that are required.
5. Tighten all the screws and nuts.
6. **Drain** the fuel tank **completely** and pull the recoil starter handle several times to remove fuel from the carburetor.
7. Remove the spark plug and pour 7 cc (1/4 oz.; 1/2 tablespoon) of fresh, clean, two-stroke engine oil into the cylinder through the spark plug hole.
  - A. Place a clean cloth over the spark plug hole.
  - B. Pull the recoil starter handle 2-3 times to distribute the oil inside the engine.
  - C. Observe the piston location through the spark plug hole. Pull the recoil starter handle slowly until the piston reaches the top of its travel and leave it there.
8. Install the spark plug (do not connect ignition cable).

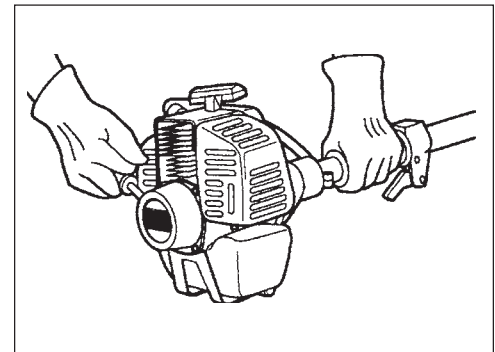
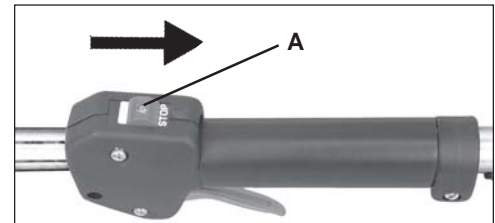

## SERVICING INFORMATION

### PARTS

Genuine ECHO Parts and ECHO REPOWER™ Parts and Assemblies for your ECHO products are available only from an Authorized ECHO Dealer. When you do need to buy parts **always** have the Model Number and Serial Number of the unit with you. You can find these numbers on the engine housing. For future reference, write them in the space provided below.

Model No. \_\_\_\_\_ SN. \_\_\_\_\_

### SERVICE

Service of this product during the warranty period must be performed by an Authorized ECHO Service Dealer. For the name and address of the Authorized ECHO Service Dealer nearest you, ask your retailer or call: 1-800-432-ECHO (3246). Dealer information is also available on our Web Site. When presenting your unit for Warranty service/repairs, proof of purchase is required.

### ECHO CONSUMER PRODUCT SUPPORT

If you require assistance or have questions concerning the application, operation or maintenance of this product you may call the ECHO Consumer Product Support Department at 1-800-673-1558 from 8:00 am to 5:00 pm (Central Standard Time) Monday through Friday. Before calling, please know the model and serial number of your unit to help your Consumer Product Support Representative.

### WARRANTY REGISTRATION

You may register your Echo equipment using the warranty registration card or register on-line at [www.echo-usa.com](http://www.echo-usa.com). Registering provides a direct link between you and ECHO if we find it necessary to contact you.

### ADDITIONAL OR REPLACEMENT MANUALS

**Safety Manuals** in English/Spanish or English/French are available, free of charge, from your ECHO dealer or at [www.echo-usa.com](http://www.echo-usa.com).

**Operator's and Parts Manuals** are available by:

- Downloading free from [www.echo-usa.com](http://www.echo-usa.com)
- Purchasing from your Echo Dealer.
- Sending a check or money order for \$2.00 per Parts Catalog or \$1.50 per Operator's Manual made payable to ECHO, INCORPORATED. State on a sheet of paper the model number and serial number of the ECHO unit you have, part number of the manual (if known), your name and address and mail to address above.

**Safety Videos** are available from your Echo dealer. A \$5.00 shipping charge will be required for each video.

#### Available Parts Catalog

PAS-260 S/N 003001001 & UP

PART NUMBER 99922203280



### DEALER?

Call  
**1-800-432-ECHO**  
or  
[www.echo-usa.com](http://www.echo-usa.com)

### CONSUMER PRODUCT SUPPORT

**1-800-673-1558**  
**8 - 5 Mon - Fri C.S.T.**



# ECHO

ECHO, INCORPORATED

400 OAKWOOD ROAD  
LAKE ZURICH, IL 60047

[www.echo-usa.com](http://www.echo-usa.com)