



Power Blower

Operator's Manual

MODEL PB-260L
Serial Number 05001001 - 05999999

WARNING  **DANGER**



The muffler or catalytic muffler and surrounding cover may become extremely hot.

Always keep clear of exhaust and muffler area, otherwise serious personal injury may occur.



WARNING



The engine exhaust from this product contains chemicals known to the State of California to cause cancer, birth defects or other reproductive harm.



WARNING  **DANGER**

Read rules for safe operation and instructions carefully. ECHO provides this Operator's Manual, which must be read and understood for proper and safe operation.

INTRODUCTION

Welcome to the ECHO family. This ECHO product was designed and manufactured to provide long life and on-the-job-dependability. Read and understand this manual. You will find it easy to use and full of helpful operating tips and SAFETY messages.

THE OPERATOR'S MANUAL

Read and understand this manual before operation. Keep it in a safe place for future reference. It contains specifications and information for operation, starting, stopping, maintenance, storage, and assembly specific to this product.

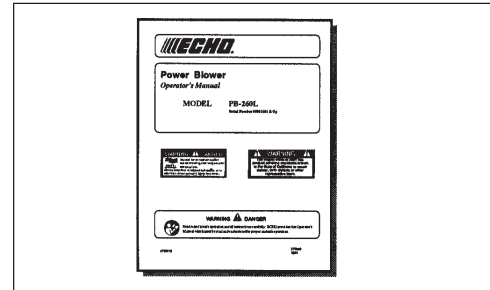



TABLE OF CONTENTS

| | | | |
|--|----|---|----|
| Introduction | 2 | - Stopping Engine | 13 |
| - The Operator's Manual | 2 | - Operating Blower | 14 |
| Manual Safety Symbols and Important Information .. | 3 | Maintenance | 15 |
| Safety | 3 | - Skill Levels | 15 |
| - Decals | 3 | - Maintenance Intervals | 15 |
| - International Symbols | 4 | - Air Filter | 16 |
| Safety Instructions | 4 | - Fuel Filter | 16 |
| - Personal Condition and Safety Equipment | 4 | - Spark Plug | 17 |
| - Extended Operation/Extreme Conditions | 5 | - Cooling System | 17 |
| - Equipment | 5 | - Exhaust System | 18 |
| - Safe Operation | 6 | - Carburetor Adjustment | 19 |
| Emission Control | 6 | Troubleshooting | 20 |
| Description | 7 | Storage | 21 |
| - Contents | 7 | Servicing Information | 24 |
| Specifications | 9 | - Parts | 24 |
| Assembly | 10 | - Service | 24 |
| - Install Blower Pipes | 10 | - ECHO Consumer Product Support | 24 |
| Pre-Operation | 11 | - Warranty Card | 24 |
| - Fuel | 11 | - Additional or Replacement Manuals | 24 |
| Operation | 12 | | |
| - Starting Cold Engine | 12 | | |
| - Starting Warm Engine | 13 | | |

Specifications, descriptions and illustrative material in this literature are as accurate as known at the time of publication, but are subject to change without notice. Illustrations may include optional equipment and accessories, and may not include all standard equipment.

MANUAL SAFETY SYMBOLS AND IMPORTANT INFORMATION

Throughout this manual and on the product itself, you will find safety alerts and helpful, informational messages preceded by symbols or key words. The following is an explanation of those symbols and key words and what they mean to you.

 This symbol accompanied by the words **WARNING** and **DANGER** calls attention to an act or condition that can lead to serious personal injury to operator and bystanders.

 The circle with the slash symbol means whatever is shown within the circle is prohibited.

 **IMPORTANT**  **NOTE**

IMPORTANT The enclosed message provides information necessary for the protection of the unit.

NOTE This enclosed message provides tips for use, care and maintenance of the unit.

SAFETY

DECALS

Locate these safety decals on your unit. Make sure the decals are legible and that you understand and follow the instructions on them. If a decal cannot be read, a new one can be ordered from your ECHO dealer. See PARTS ORDERING instructions for specific information.

Hot Decal (near muffler)

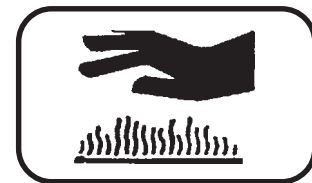

P/N 89016006361

General Warning Decal (located on blower housing)



P/N 89016009461

65 dB(A) **Category I**
Measured at 50 ft. (15m) per ANSI B175.2

P/N X508000120

INTERNATIONAL SYMBOLS

| Symbol form/shape | Symbol description/application | Symbol form/shape | Symbol description/application |
|-------------------|--|-------------------|---------------------------------------|
| | Read and understand Operator's Manual. | | Fuel and oil mixture |
| | Wear eyes, ears and head protection | | Finger Severing |
| | Hot Surface | | Wear hand protection. Use two handed. |
| | Safety/Alert | | Wear slip resistant foot wear. |
| | DO NOT allow flames or sparks near fuel. | | DO NOT smoke near fuel. |

| Symbol form/shape | Symbol description/application | Symbol form/shape | Symbol description/application |
|-------------------|--|-------------------|--|
| | Emergency stop | | Ignition ON/OFF |
| | Carburetor adjustment - Low speed mixture | | Primer bulb |
| | Carburetor adjustment - Idle speed | | Carburetor adjustment - High speed mixture |
| | Choke Control "Cold Start" Position (Choke Closed) | | Choke Control "Run" Position (Choke Open) |

SAFETY INSTRUCTIONS

PERSONAL CONDITION AND SAFETY EQUIPMENT

WARNING DANGER

Power Blower users risk injury to themselves and others if the Power Blower is used improperly and/or safety precautions are not followed. Proper clothing and safety gear must be worn when operating a Power Blower.

Physical Condition

Your judgment and physical dexterity may not be good:

- if you are tired or sick,
- if you are taking medication,
- if you have taken alcohol or drugs.

Operate unit only if you are physically and mentally well.

Eye Protection

Wear eye protection that meets ANSI Z87.1 or CE requirements whenever you operate the blower.

Hand Protection

Wear no-slip, heavy duty work gloves to improve your grip on the blower handle. Gloves also reduce the transmission of machine vibration to your hands.

Breathing Protection

Wear a face mask to protect against dust.

Hearing Protection

ECHO recommends wearing hearing protection whenever unit is used.

Proper Clothing

Wear snug fitting, durable clothing;

- Pants should have long legs, shirts with long sleeves.
- DONOTWEARSHORTS,
- DONOTWEARTIES,SCARVES,JEWELRY.

Wear sturdy work shoes with nonskid soles;

- DONOTWEAROPENTOEDSHOES,
- DONOTOPERATEUNITBAREFOOTED.

Keep long hair away from engine and blower intake. Retain hair with cap or net.

Hot Humid Weather

Heavy protective clothing can increase operator fatigue which may lead to heat stroke. Schedule heavy work for early morning or late afternoon hours when temperatures are cooler.

EXTENDED OPERATION/EXTREME CONDITIONS

Vibration and Cold --

It is believed that a condition called Raynaud's Phenomenon, which affects the fingers of certain individuals, may be brought about by exposure to vibration and cold. Exposure to vibration and cold may cause tingling and burning sensations, followed by loss of color and numbness in the fingers. The following precautions are strongly recommended, because the minimum exposure which might trigger the ailment is unknown.

- Keep your body warm, especially the head, neck, feet, ankles, hands, and wrists.
- Maintain good blood circulation by performing vigorous arm exercises during frequent work breaks, and also by not smoking.
- Limit the hours of operation. Try to fill each day with jobs where operating the blower or other hand-held power equipment is not required.
- If you experience discomfort, redness and swelling of the fingers followed by whitening and loss of feeling, consult your physician before further exposing yourself to cold and vibration.

Repetitive Stress Injuries --

It is believed that overusing the muscles and tendons of the fingers, hands, arms, and shoulders may cause soreness, swelling, numbness, weakness, and extreme pain in those areas. Certain repetitive hand activities may put you at a high risk for developing a Repetitive Stress Injury (RSI). An extreme RSI condition is Carpal Tunnel Syndrome (CTS), which could occur when your wrist swells and squeezes a vital nerve that runs through the area. Some believe that prolonged exposure to vibration may contribute to CTS. CTS can cause severe pain for months or even years.

To reduce the risk of RSI/CTS, do the following:

- Avoid using your wrist in a bent, extended, or twisted position. Instead, try to maintain a straight wrist position. Also, when grasping, use your whole hand, not just the thumb and index finger.
- Take periodic breaks to minimize repetition and rest your hands.
- Reduce the speed and force with which you do the repetitive movement.
- Do exercises to strengthen the hand and arm muscles.
- Immediately stop using all power equipment and consult a doctor if you feel tingling, numbness, or pain in the fingers, hands, wrists or arms. The sooner RSI/CTS is diagnosed, the more likely permanent nerve and muscle damage can be prevented.

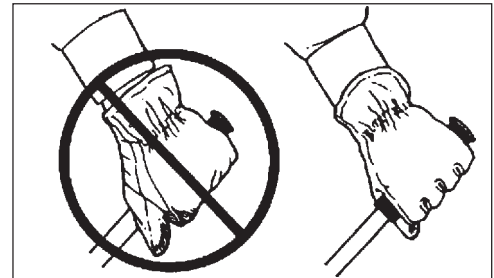

EQUIPMENT

- Check unit for loose/missing nuts, bolts, and screws. Tighten and/or replace as needed.
- Inspect fuel lines, tank, and area around carburetor for fuel leaks. **DO NOT** operate unit if leaks are found.
- Do not use blower if any part is missing or damaged.
- Have repairs done only by an authorized ECHO Service dealer.
- Do not use any attachment, accessory, or replacement part unless it is recommended in this Operator's Manual.
- Avoid contact during and immediately after operation. Always keep exhaust area clear of flammable debris. Allow the engine and muffler to completely cool before performing any maintenance activity.

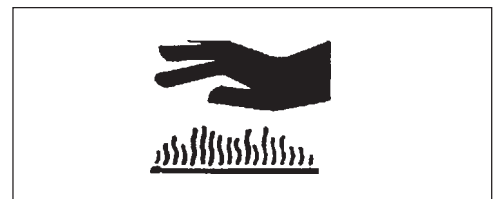

SAFE OPERATION

WARNING DANGER

Do not operate this product indoors or in inadequately ventilated areas. Engine exhaust contains poisonous emissions and can cause serious injury or death.

Determine Operation Area

- Review area to be cleared. Look for potential hazards such as stones or metal objects.
- Take wind conditions into account: avoid open doors and windows.
- Do not point blower at people or animals.
- Start unit on ground with throttle at idle. Check that blower pipe is not blocked by the ground or by any objects.

Read the Manuals

- Provide all users of this equipment with the Operator's Manual and Safety Manual for instructions on Safe Operation.

Keep A Firm Grip

- Hold handle with fingers together encircling the handle.

Clear the Work Area

- Spectators and fellow workers must be warned, and children and animals prevented from coming nearer than 15 m (50 ft.) while the unit is in use.

Keep A Solid Stance

- Maintain footing and balance at all times. Do not stand on slippery, uneven or unstable surfaces. Do not work in odd positions or on ladders.
- Do not perform Maintenance or Assembly procedures with engine running.

Noise Control

- Follow local noise regulations on sound levels and hours of operations. Use only during appropriate hours.
- Never use a higher speed setting than necessary to perform a task. The higher the engine speed the louder the blower noise.
- Be a good neighbor.

Avoid Hot Surfaces

- During operation, the muffler or catalytic muffler and surrounding cover may become extremely hot. Avoid contact during and immediately after operation. Always keep exhaust area clear of flammable debris.

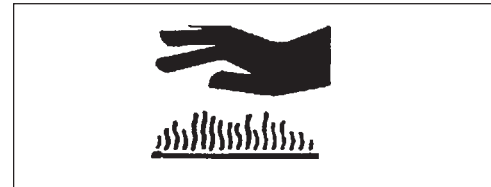

EMISSION CONTROL

EPA Phase 2

The emission control system for these engines are EM (Engine Modification).

IMPORTANT ENGINE INFORMATION

ENGINE FAMILY: 3EHXS.0254EB DISPLACEMENT: 25.4 cc
EMISSION COMPLIANCE PERIOD : 300 HRS.
THIS ENGINE MEETS U.S. EPA PHASE II EMISSION REGULATIONS FOR SMALL NON ROAD ENGINES. REFER TO OWNER'S MANUAL FOR MAINTENANCE SPECIFICATIONS AND ADJUSTMENTS.



ECHO CORP.



An Emission Control Label is located on the engine. (This is an EXAMPLE ONLY, information on label varies by engine FAMILY).

PRODUCT EMISSION DURABILITY

The 300 hour emission durability compliance period is the time span selected by the manufacturer certifying the engine emissions output meets applicable emissions regulations, provided that approved maintenance procedures are followed as listed in the Maintenance Section of this manual.

DESCRIPTION

CONTENTS

- 1 - Power Head
- 1 - Elbow Pipe
- 1 - Flex Pipe
- 1 - Swivel Pipe
- 1 - Straight Pipe
- 1 - Straight Pipe
- 1 - Plastic Bag
 - 1 - Operator's Manual
 - 1 - Warranty Registration Card
 - 1 - ECHO Emissions and Warranty Statement
 - 2 - Clamps w/screws
 - 1 - Stick Handle Assembly
- 1 - Echo Power Blend™ 2-stroke oil sample

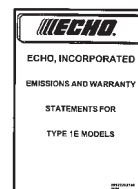
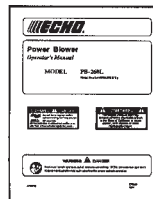

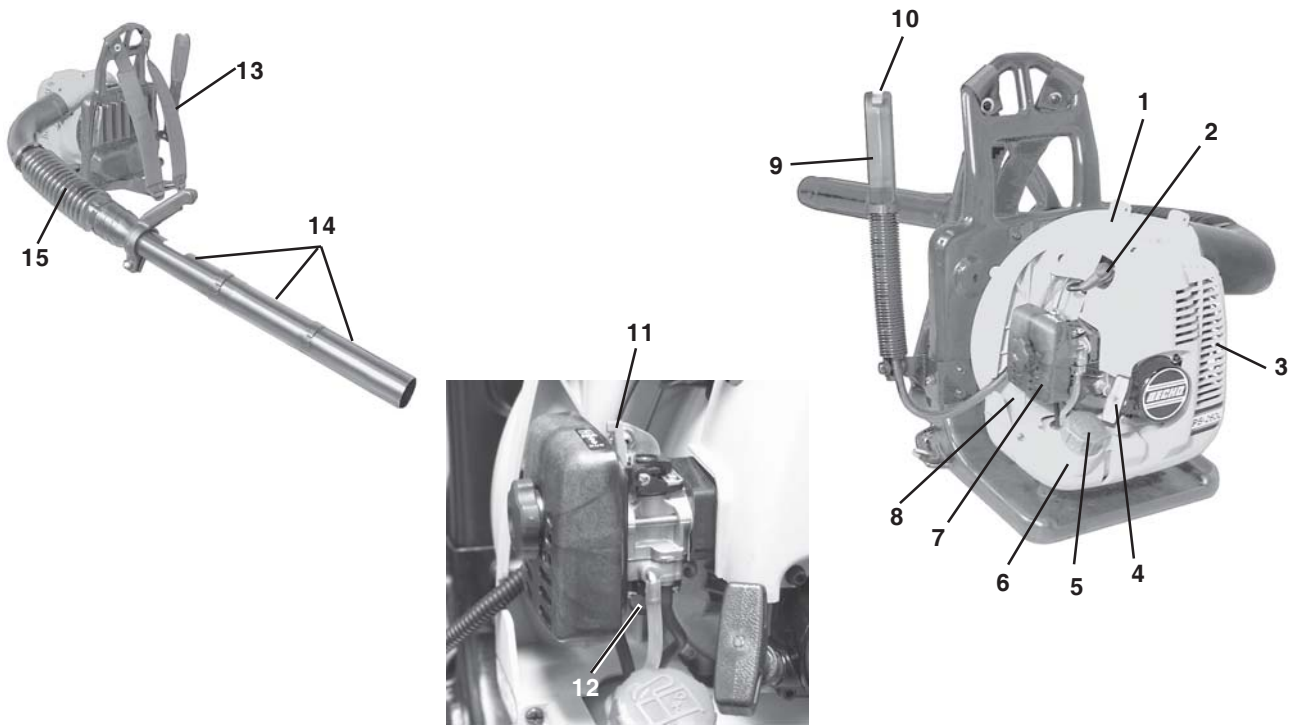

1. **SAFETY DECAL** - Lists important safety precautions.
2. **SPARK PLUG** - Provides spark to ignite fuel mixture.
3. **SPARK ARRESTOR - CATALYTIC MUFFLER/MUFFLER** - The muffler or catalytic muffler controls exhaust noise and emission. The spark arrestor screen prevents hot, glowing particles of carbon from leaving the muffler. Keep exhaust area clear of flammable debris.
4. **RECOIL STARTER HANDLE** - Pull recoil handle slowly until starter engages, then quickly and firmly. When engine starts, return handle slowly. **DO NOT** let handle snap back or damage to unit will occur.
5. **FUEL TANK CAP** - Covers and seals fuel tank.
6. **FUEL TANK** - Contains fuel and fuel filter.
7. **AIR CLEANER** - Contains replaceable air filter element.
8. **SERIAL NUMBER LABEL** - Located on underside of unit below starter housing. Lists model number and serial number of unit.
9. **HANDLE** - Rotates downward for throttle control access. Spring loaded for flexible operation.
10. **THROTTLE POSITION LEVER/STOP SWITCH** - Combination stop switch and variable speed throttle lever. When the lever is moved all the way forward the blower is at Wide Open Throttle (W.O.T.). When the lever is moved rearward to detent, the blower is at idle. When the lever is moved rearward past the idle detent the blower will stop.
11. **CHOKE** - Choke is located on the side of the air cleaner. Move choke lever to "COLD START" (🔒) to close choke for cold starting. Move choke lever to "RUN" (🔓) position to open choke.
12. **PRIMER BULB** - Pumping primer bulb before starting engine draws fresh fuel from the fuel tank priming the carburetor for starting. Pump primer bulb until fuel is visible and flows freely in the clear fuel tank return line. Pump bulb an additional 4 or 5 times.
13. **SHOULDER HARNESS** - Used to support unit on operator's back. The straps are adjustable.
14. **BLOWER PIPES** - Twist lock design.
15. **FLEXIBLE PIPE** - Allows for full range of movement.

SPECIFICATIONS

| | |
|---|--|
| MODEL | PB-260L |
| Length | 375 mm (14.8 in.) |
| Width | 410 mm (16.1 in.) |
| Height | 460 mm (18.1 in.) |
| Weight with pipes | 6.0 kg (13.2 lb.) |
| Engine Type | Air cooled, two-stroke, single cylinder gasoline engine |
| Displacement | 25.4 cc (1.55 cu. in.) |
| Bore | 34.0 cc (1.34 in.) |
| Stroke | 28.0 mm (1.10 in.) |
| Carburetor | Walbro Diaphragm model w/primer bulb |
| Ignition System | Flywheel Magneto, capacitor discharge ignition type |
| Spark Plug | NGK BPM-8Y Gap 0.65 mm (0.026 in.) |
| Exhaust System | Spark Arrestor Muffler |
| Fuel | Mixed (Gasoline and Two-stroke Oil) |
| Fuel/Oil Ratio | 50:1 two-stroke air cooled engine oil |
| Gasoline | 89 Octane unleaded. DO NOT use fuel containing methyl alcohol, more than 10% ethyl alcohol or 15% MTBE. |
| Oil | Power Blend™ Premium Universal 2-Stroke Oil |
| Fuel Tank Capacity | 0.6 lit. (20.3 US fl. oz.) |
| Recoil Starter System | Automatic Recoil Starter Centrifugal Type |
| Idle Speed | 2,400 - 3,200 (RPM) |
| Wide Open Throttle Speed | 7,000 - 9,000 (RPM) |
| Maximum Air Speed (Measured at pipe end) | 70 m/sec. (156 mph) |
| Average Air Volume (Measured at pipe end) | 9.5 m ³ /min. (335 cu. ft./min.) |
| Sound Level at 50 ft. dB(A) scale per ANSI B175.2 | 65 dB(A) |

ASSEMBLY

WARNING DANGER

Never perform maintenance or assembly procedures with engine running or serious personal injury may result.

INSTALL BLOWER PIPES

1. Remove elbow retaining screw from blower housing.
2. Align grooves in elbow with pegs on blower housing and slide pipe onto housing.
3. Turn elbow clockwise to lock into place and align location holes (A) in elbow and blower housing.
4. Insert elbow retaining screw through holes (A) and tighten.
5. Assemble clamps (B) onto both ends of flexible pipe (C).

NOTE

A light lubricant may be used to ease assembly of flexible pipe to blower elbow.

6. Assemble straight pipe with swivel (D) into flexible pipe (C) and tighten clamp (B).
7. Assemble flexible pipe (C) to elbow (E) on blower and tighten clamp (B).
8. Loosen wing nut (F) completely and expand stick handle (G).
9. Align notch (H) in handle clamp with pipe pegs (J). Handle should be angled away from operator.
10. Slide handle onto swivel pipe.
11. Position handle for comfortable operation and tighten wing nut.
12. Assemble straight pipe (K and L) to swivel pipe, turning straight pipe clockwise to lock in place.

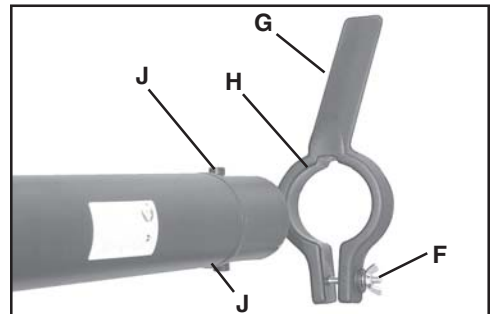
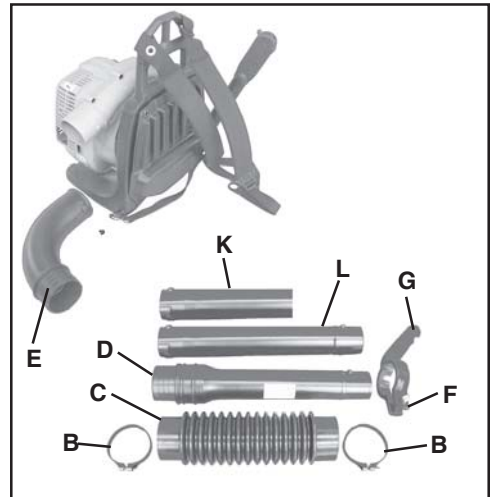
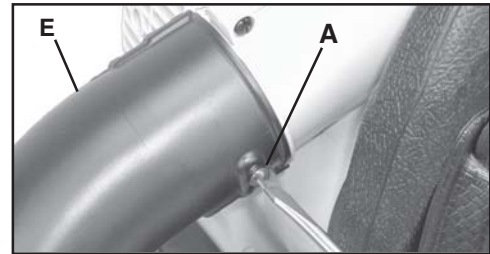
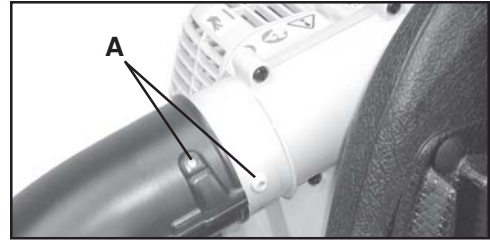

PRE-OPERATION

FUEL

Fuel Requirements

Gasoline - Use 89 Octane [R+M/2] (mid grade or higher) gasoline known to be good quality. Gasoline may contain up to 15% MTBE (methyl tertiary-butyl ether). Gasohol containing methyl (wood) alcohol is **NOT** approved.

Two Stroke Oil - A two-stroke engine oil meeting ISO-L-EGD (ISO/CD 13738) and J.A.S.O. FC Standards must be used. Echo brand premium Power Blend™ Universal 2-Stroke Oil meets these standards. Engine problems due to inadequate lubrication caused by failure to use an ISO-L-EGD and J.A.S.O. FC certified oil, such as Echo premium Power Blend™, will void the two-stroke engine warranty. (Emission related parts only are covered for two years, regardless of two-stroke oil used, per the statement listed in the Emission Defect Warranty Explanation.)

IMPORTANT

Echo premium Power Blend™ Universal 2-Stroke Oil may be mixed at 50:1 ratio for application in all Echo engines sold in the past regardless of ratio specified in those manuals.

Mixing Instructions

1. Fill an approved fuel container with half of the required amount of gasoline.
2. Add the proper amount of 2-stroke oil to gasoline.
3. Close container and shake to mix oil with gasoline.
4. Add remaining gasoline and remix.
5. Install fuel container cap and wipe any spilled fuel from container and surrounding area.

Handling Fuel

WARNING



DANGER

Fuel is **VERY** flammable. Use extreme care when mixing, storing or handling or serious personal injury may result.

- Use an approved fuel container.
- **DO NOT** smoke near fuel.
- **DO NOT** allow flames or sparks near fuel.
- Fuel tanks/cans may be under pressure. Always loosen fuel caps slowly allowing pressure to equalize.
- **NEVER** refuel a unit when the engine is **HOT!**
- **NEVER** refuel a unit with the engine running.
- **DO NOT** fill fuel tanks indoors. **ALWAYS** fill fuel tanks outdoors over bare ground.
- Securely tighten fuel cap after refueling.
- Inspect for fuel leakage. If fuel leakage is found, do not start or operate unit until leakage is repaired.

IMPORTANT

Spilled fuel is a leading cause of hydrocarbon emissions. Some states may require the use of automatic fuel shut-off containers to reduce fuel spillage. Contact your ECHO dealer for ordering information.

After Refueling

- Wipe any spilled fuel from the unit.
- Move at least 3 m (10 ft.) from refueling location before starting.

After use

- **DO NOT** store a unit with fuel in its tank. Leaks can occur. Return unused fuel to an approved fuel storage container.

Storage

Fuel storage laws vary by locality. Contact your local government for the laws affecting your area. As a precaution, store fuel in an approved, air tight container. Store in a well ventilated, unoccupied building, away from sparks and flames. Do not store fuel longer than 30 days.

IMPORTANT

Stored fuel ages. Do not mix more fuel than you expect to use in thirty (30) days, ninety (90) days when a fuel stabilizer is added.

Stored two-stroke fuel may separate. **ALWAYS** shake fuel container thoroughly before each use.

OPERATION

- Check unit for loose nuts, bolts and screws daily.
- Recoil starter: Use short pulls - only 1/2-2/3 of rope length for starting. Do not allow the rope to snap back in. Always hold the unit firmly.
- Rotate throttle handle downward to a comfortable operating position.

STARTING COLD ENGINE

1. *Throttle Lever*
Move throttle lever (A) to START/IDLE DETENT position.
2. *Choke*
Move choke (B) to "Cold Start" (←) position.
3. *Primer*
Pump primer bulb (C) until fuel is visible and flows freely in the clear fuel tank return line. Pump bulb an additional 4 or 5 times.
4. *Recoil Starter*
Pull recoil starter handle (D) until engine fires, or maximum 5 pulls.
5. *Choke*
Move choke (B) to run (↕) position and if necessary, restart engine.

NOTE

If engine does not start after 5 pulls, repeat instructions 2-5.

NOTE

Allow engine to warm up before use.

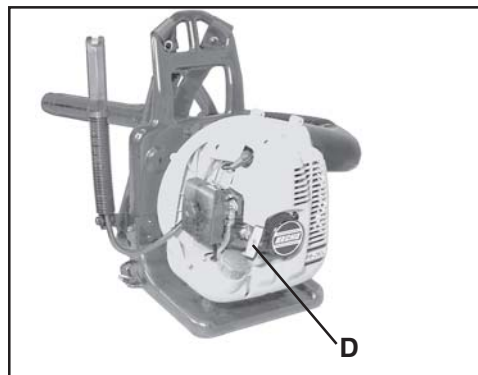
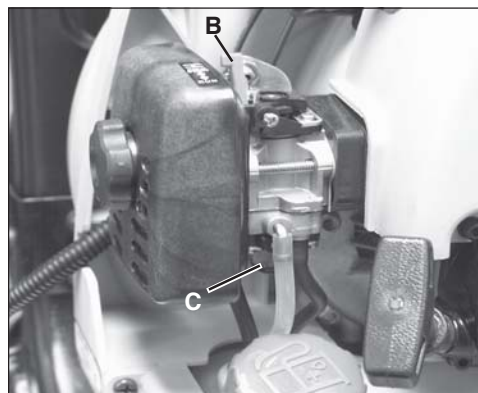
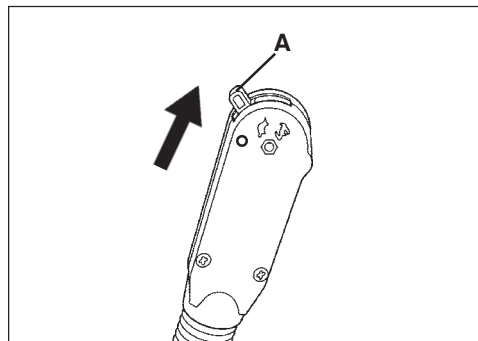

STARTING WARM ENGINE

The starting procedure is the same as Cold Start except DO NOT close the choke.

1. *Throttle Lever*
Move throttle lever (A) to start/idle detent position.
2. *Primer*
Pump primer bulb (C) until fuel is visible and flows freely in the clear fuel tank return line. Pump bulb an additional 4 or 5 times.
3. *Recoil Starter*
Pull recoil starter handle (D) and engine should start.

NOTE

If engine does not start after 5 pulls, use cold start procedures.

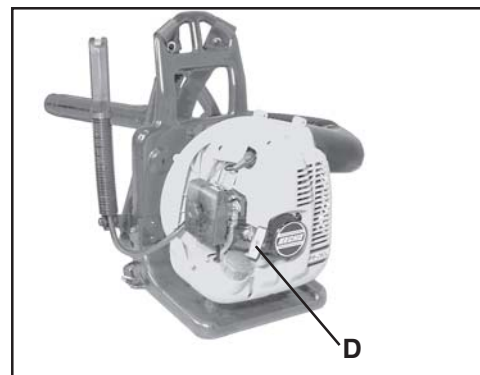
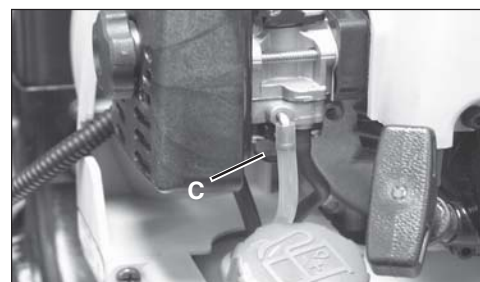
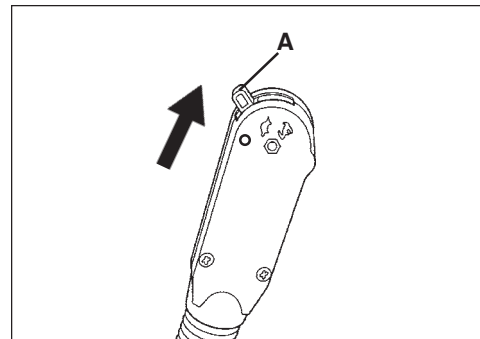

STOPPING ENGINE

1. *Throttle Lever*
Move throttle lever (A) to idle detent position and allow engine to return to idle before shutting off engine.
2. Move throttle lever (A) to "O" (Stop) position.

WARNING DANGER

If engine does not stop when stop switch is moved to STOP position, close choke - COLD START position - to stall engine. Have your ECHO dealer repair stop switch before using blower again.

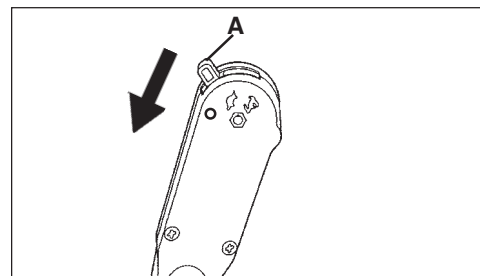

OPERATING BLOWER

WARNING DANGER

Always wear safety glasses, hearing protection, face filter mask and take all safety precautions or serious personal injury may result.

Do not point the blower pipe in the direction of people or pets.

Read the Safety Section carefully.

IMPORTANT

To avoid engine damage due to over revving, do not block blower pipe opening.

1. Use only during appropriate hours.
2. Allow the engine to warm up at a fast idle for a few minutes.
3. Set engine speed with throttle lever (A).
4. Use lower speed to blow dry grass and leaves from walks, patios and drives.
5. Additional speed may be necessary to clean leaves from a lawn or flower bed.
6. Higher speed may be necessary to move gravel, dirt, snow, bottles or cans from a driveway, street, parking lot or stadium.

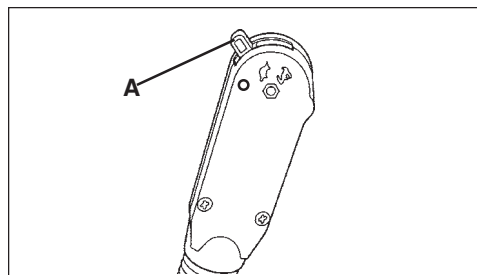

NOTE

Never use a higher speed setting than necessary to perform a task. Remember, the higher the engine speed, the louder the blower noise. Minimize dust by using blower at lower speeds and by dampening material with water/mist when necessary. Keep debris on your property.
Be Smart - be a good neighbor.

MAINTENANCE

Your ECHO blower is designed to provide many hours of trouble free service. Regular scheduled maintenance will help your blower achieve that goal. If you are unsure or are not equipped with the necessary tools, you may want to take your unit to an ECHO Service Dealer for maintenance. To help you decide whether you want to DO-IT-YOURSELF or have the ECHO Dealer do it, each maintenance task has been graded. If task is not listed, see your ECHO Dealer for repairs.

SKILL LEVELS

- Level 1**= Easy to do. Most required tools come with unit.
- Level 2**= Moderate difficulty. Some specialized tools may be required.
- Level 3**= Experience required. Specialized tools are required. Echo recommends that the unit be returned to your ECHO dealer for service.

ECHO offers **REPOWER™** Maintenance Kits and Parts to make your maintenance job easier. Just below each task heading are listed the various part numbers required for that task. See your ECHO dealer for these parts.

MAINTENANCE INTERVALS

AIR FILTER

Level 1.

Tools required: 25-50 mm (1-2 in.) Cleaning brush

Parts required: 90030 REPOWER™ Air and Filter Kit

NOTE

Clean daily.

1. Close choke (Cold Start Position). This prevents dirt from entering the carburetor throat when the air filter is removed. Brush accumulated dirt from the air cleaner area.
2. Remove the air cleaner cover. Clean and inspect the element for damage. If element is fuel soaked and very dirty, replace.
3. If element can be cleaned and reused, be certain it:
 - still fits the cavity in the air cleaner cover.
 - is installed with the original side out.



FUEL FILTER

Level 1.

Tools required: 200-250 mm (8-10 in.) length of wire with one end bent into a hook, clean rag, funnel, and an approved fuel container

Parts required: 90030 REPOWER™ Air and Filter Kit

WARNING DANGER

Fuel is **VERY** flammable. Use extreme care when mixing, storing or handling.

1. Use a clean rag to remove loose dirt from around fuel cap and empty fuel tank.
2. Use the “fuel line hook” to pull the fuel line and filter from the tank.
3. Remove the filter from the line and install the new filter.



SPARK PLUG

Level 2.

Tools required: 3/4 in. Spark plug deep socket, feeler gauge

Parts Required: Spark Plug, NGK BPM-8Y P/N 15901019830

1. Remove spark plug and check for fouling, worn and rounded center electrode.
2. Clean the plug or replace with a new one. DO NOT sand blast to clean. Remaining sand will damage engine.
3. Adjust spark plug gap by bending outer electrode.
4. Tighten spark plug to 145-155 kg/cm (125-135 in. lb.).

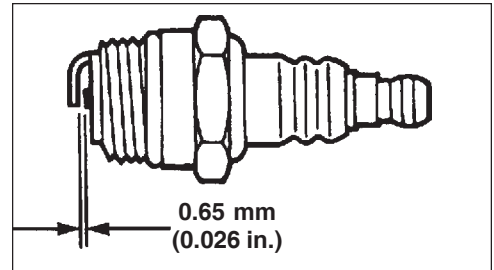
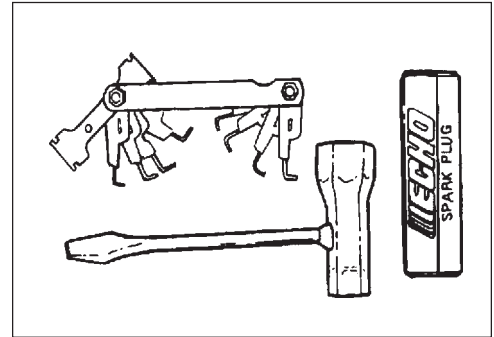

COOLING SYSTEMS CLEANING

Level 2.

Tools required: 25-50 mm (1-2 in.) cleaning brush, 3 mm hex wrench, cross head screwdriver, pointed wood stick

Parts Required: None, if you are careful.

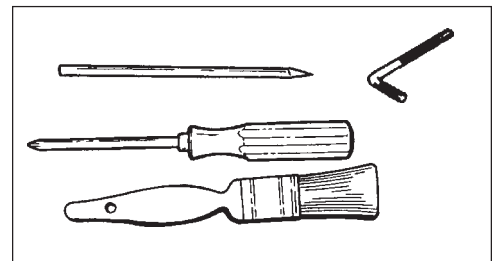

IMPORTANT

To maintain proper engine operating temperatures, cooling air must pass freely through the cylinder fin area. This flow of air carries combustion heat away from the engine.

Overheating and engine seizure can occur when:

- Air intakes are blocked, preventing cooling air from reaching the cylinder.
- Dust and grass build up on the outside of the cylinder. This build up insulates the engine and prevents the heat from leaving.

Removal of cooling passage blockages or cleaning of cooling fins is considered "Normal Maintenance." Any failure attributed to lack of maintenance is not warranted.

Cleaning Grill

1. Remove accumulated debris from intake grill between backpack frame and blower housing.

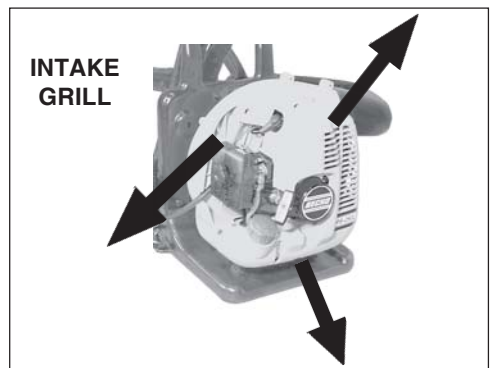

Cleaning Cylinder Fins

1. Remove engine cover (six screws), pull cover away from engine. Clean cylinder fins to allow cooling air to pass freely.

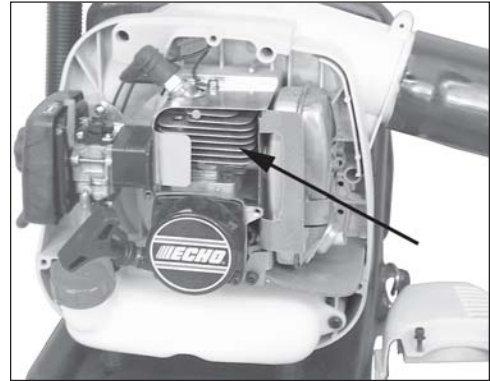

EXHAUST SYSTEM

Spark Arrestor Screen

Level 2.

Tools required: Cross Head Screwdriver, 3 mm Hex Wrench,
Soft metal brush

Parts Required: Spark arrestor screen P/N 14586240630,
Gasket P/N V104000350

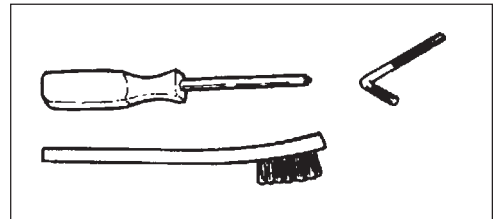

IMPORTANT

Carbon deposits in muffler will cause a drop in engine output and overheating. Spark arrestor screen must be checked periodically.

1. Remove engine cover (six screws).
2. Remove exhaust deflector (A), spark arrestor cover (B), gasket (C), and spark arrestor screen (D) from muffler. Replace screen if plugged with carbon deposits.
3. Install spark arrestor screen, gaskets, and covers.
4. Install engine cover.

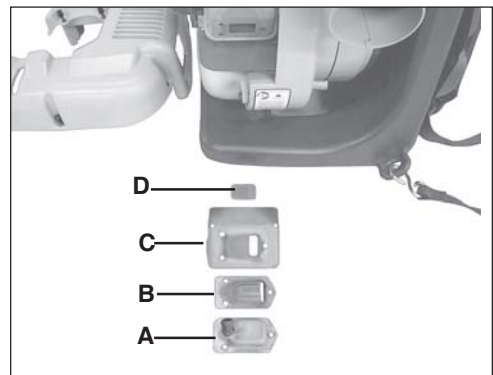

Cylinder Exhaust Port

Level 3.

IMPORTANT

The cylinder exhaust port must be inspected and cleaned of excess carbon every 3 months or 90 hours of operation in order to maintain this engine within the emissions durability period. ECHO strongly recommends that you return your unit to your ECHO dealer for this important maintenance service.

CARBURETOR ADJUSTMENT

Level 2.

Tools required: Screwdriver, tachometer (Echo P/N 99051130017)

Parts required: None.

NOTE

Every unit is run at the factory and the carburetor is set in compliance with emission regulations. Carburetor adjustments, other than idle speed, must be performed by an authorized ECHO dealer.

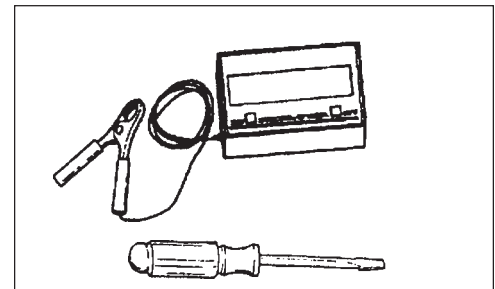

Before Adjustment

Check that:

- Air filter is clean and properly installed.
 - Spark arrestor screen is free of carbon.
 - Blower pipes are installed.
1. Start engine, run at idle for one minute.
 2. Complete warm up by running at full throttle for 5 minutes, operating choke twice to clear air from carburetor chambers.
 3. Check idle speed and reset if necessary. If a tachometer is available, idle speed screw (A) should be set to the specifications found on Page 9 "Specifications" of this manual. Turn idle screw (A) clockwise to increase idle speed; counter clockwise to decrease idle speed.

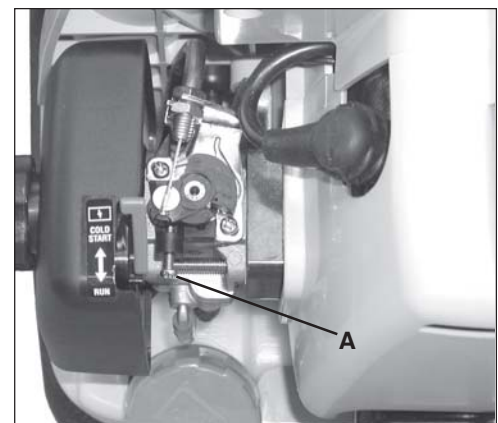

TROUBLESHOOTING

| TROUBLESHOOTING CHART | | | | |
|---|---------------------------|-------------------------------|--|---|
| Problem | Check | Status | Cause | Remedy |
| Engine cranks - starts hard/ doesn't start | Fuel at carburetor | No fuel at carburetor | Fuel strainer clogged Fuel line clogged Carburetor | Clean or replace Clean or replace See your Echo dealer |
| | Fuel at cylinder | No fuel at cylinder | Carburetor | See your Echo dealer |
| | | Muffler wet with fuel | Fuel Mixture too rich | Open choke Clean/replace air filter Adjust carburetor See your Echo dealer |
| | Spark at end of plug wire | No spark | Stop switch off Electrical problem Interlock switch | Turn switch to ON See your Echo dealer See your Echo dealer |
| | Spark at plug | No spark | Spark gap incorrect Covered with carbon Fouled with fuel Plug defective | Adjust to .65mm (0.026 in.) Clean or replace Clean or replace Replace plug |
| Engine runs, but dies or does not accelerate properly | Air filter | Air filter dirty | Normal wear | Clean or replace |
| | Fuel filter | Fuel filter dirty | Contaminants/residues in fuel | Replace |
| | Fuel vent | Fuel vent plugged | Contaminants/residues in fuel | Clean or replace |
| | Spark Plug | Plug dirty/worn | Normal wear | Clean and adjust or replace |
| | Carburetor | Improper adjustment | Vibration | Adjust |
| | Cooling System | Cooling system dirty/plugged | Extended operation in dirty/dusty locations | Clean |
| | Spark Arrestor Screen | Spark arrestor screen plugged | Normal wear | Replace |
| Engine does not crank | N/A | N/A | Internal engine problem | See your Echo dealer |
| Engine runs, blower doesn't work or is weak/uneven | Blower pipe | Pipe clogged | Build-up of debris | Unclog |
| | | Pipe loose | Vibration | Tighten |
| | | Pipe damaged | Wear/Misuse | Replace |

WARNING DANGER

Fuel vapors are **extremely** flammable and may cause fire and/or explosion. **Never** test for ignition spark by grounding spark plug against cylinder, otherwise serious personal injury may result.

STORAGE

WARNING  **DANGER**

During operation the muffler - catalytic muffler and surrounding cover become hot. Always keep exhaust area clear of flammable debris during transportation or when storing, otherwise serious property damage or personal injury may result.

Long Term Storage (Over 30 Days)

Do not store your unit for a prolonged period of time (30 days or longer) without performing protective storage maintenance which includes the following:

1. Store unit in a dry, dust free place, out of the reach of children.

WARNING  **DANGER**

Do not store where fuel fumes may accumulate or reach an open flame or spark.

2. Place the stop switch in the "STOP" position.
3. Remove accumulation of grease, oil, dirt and debris from exterior of unit.
4. Perform all periodic lubrication and services that are required.
5. Tighten all screws and nuts.
6. **Drain** the fuel tank **completely** and pull the recoil starter handle several times to remove fuel from the carburetor.
7. Remove the spark plug and pour 7cc (1/4 oz.) of fresh, clean ECHO 2-stroke engine oil into the cylinder through the spark plug hole.
 - A. Place a clean cloth over the spark plug hole.
 - B. Pull the recoil starter handle 2-3 times to distribute the oil inside the engine.
 - C. Observe the piston location through the spark plug hole. Pull the recoil handle slowly until the piston reaches the top of its travel and leave it there.
8. Install the spark plug (do not connect ignition cable).
9. Remove blower pipe assembly from unit.

NOTES

NOTES

SERVICING INFORMATION

PARTS

Genuine ECHO Parts and ECHO REPOWER™ Parts and Assemblies for your ECHO products are available only from an Authorized ECHO Dealer. When you do need to buy parts **always** have the Model Number and Serial Number of the unit with you. You can find these numbers on the engine housing. For future reference, write them in the space provided below.

Model No. _____ SN. _____

SERVICE

Service of this product during the warranty period must be performed by an Authorized ECHO Service Dealer. For the name and address of the Authorized ECHO Service Dealer nearest you, ask your retailer or call: 1-800-432-ECHO (3246). Dealer information is also available on our Web Site. When presenting your unit for Warranty service/repairs, proof of purchase is required.

ECHO CONSUMER PRODUCT SUPPORT

If you require assistance or have questions concerning the application, operation or maintenance of this product you may call the ECHO Consumer Product Support Department at 1-800-673-1558 from 8:30 am to 4:30 pm (Central Standard Time) Monday through Friday. Before calling, please know the model and serial number of your unit to help your Consumer Product Support Representative.

WARRANTY REGISTRATION

You may register your Echo equipment using the warranty registration card or register on-line at www.echo-usa.com. Registering provides a direct link between you and ECHO if we find it necessary to contact you.

ADDITIONAL OR REPLACEMENT MANUALS

Safety Manuals in English/Spanish or English/French are available, free of charge, from your ECHO dealer or at www.echo-usa.com.

Operator's and Parts Manuals are available by:

- Downloading free from www.echo-usa.com
- Purchasing from your Echo Dealer.
- Sending a check or money order for \$2.00 per Parts Catalog or \$1.50 per Operator's Manual made payable to ECHO, INCORPORATED. State on a sheet of paper the model number and serial number of the ECHO unit you have, part number of the manual (if known), your name and address and mail to address below.

Safety Videos are available from your Echo dealer. A \$5.00 shipping charge will be required for each video.

Available Parts Catalog

PB-260L

S/N 05001001 - 05999999

Part Number 99922203518



DEALER?

Call

1-800-432-ECHO

or

www.echo-usa.com

CONSUMER PRODUCT SUPPORT

1-800-673-1558

8:30 - 4:30 Mon - Fri C.S.T.



ECHO

ECHO, INCORPORATED

400 OAKWOOD ROAD
LAKE ZURICH, IL 60047

www.echo-usa.com