



RB-80 Broadcast Spreader Operator's Manual



SERIAL NUMBER
NÚMERO DE SERIE

N26500001001 – N26500999999

ECHO, INCORPORATED

400 Oakwood Road, Lake Zurich, Illinois 60047
WWW.ECHO-USA.COM

©2017 ECHO, Incorporated. All Rights Reserved

99922205207

Revised 9/01/2017

016653 R1120

⚠ WARNING ⚠

Carefully Read These Instructions Before Use

IMPROPER USE OR FAILURE TO FOLLOW INSTRUCTIONS CAN RESULT IN PRODUCT FAILURE OR INJURIES. FOR SAFE USE OF THIS PRODUCT YOU MUST READ AND FOLLOW ALL INSTRUCTIONS BEFORE USING.

⚠ WARNING: Cancer and Reproductive Harm.

⚠ www.P65Warnings.ca.gov.

- Do not allow anyone to operate the broadcast spreader without proper instructions
- Do not permit children to operate the broadcast spreader
- Wear protective eyewear and gloves when handling and applying lawn and garden chemicals
- Read the chemical label instructions and warnings for handling and applying the chemicals you plan to spread – application settings provided are only a guideline

⚠ ADVERTENCIA ⚠

Lea estas instrucciones atentamente antes de utilizarlo

EL USO INAPROPIADO O NO SEGUIR LAS INSTRUCCIONES PUEDE RESULTAR EN FALLAS DEL PRODUCTO O LESIONES. PARA USAR ESTE PRODUCTO DE MANERA SEGURA DEBE LEER Y SEGUIR TODAS LAS INSTRUCCIONES ANTES DE USARLO.

⚠ ADVERTENCIA: Cáncer y Daños Reproductivos.

⚠ www.P65Warnings.ca.gov.

- No permita que nadie opere el esparcidor a voleo sin las instrucciones apropiadas
- No permita que niños operen el esparcidor a voleo
- Use gafas de seguridad y guantes al manejar y aplicar sustancias químicas a patios y jardines
- Lea las instrucciones y advertencias químicas en la etiqueta respecto al manejo y aplicación de las sustancias que planea esparcir – las configuraciones de aplicación proporcionadas son sólo una guía

⚠ AVERTISSEMENT ⚠

Lisez attentivement ces instructions avant l'utilisation

UNE MAUVAISE UTILISATION, OU DE NE PAS SUIVRE LES INSTRUCTIONS PEUT, MENER À UNE DÉFAILLANCE DU PRODUIT OU À DES BLESSURES. POUR UTILISER CE PRODUIT SANS DANGER, VOUS DEVEZ LIRE ET SUIVRE TOUTES LES INSTRUCTIONS AVANT L'UTILISATION.

⚠ AVERTISSEMENT : Cancer et Dommages Reproductifs.

⚠ www.P65Warnings.ca.gov.

- Ne laissez personne utiliser l'épandeur centrifuge sans les instructions appropriées.
- Ne laissez aucun enfant utiliser l'épandeur centrifuge.
- Portez des lunettes de protection et des gants lors de la manipulation et l'application de produits chimiques pour le gazon et le jardin
- Lisez les étiquettes d'instructions et d'avertissement des produits chimiques pour manipuler et appliquer les produits chimiques que vous planifiez épandre – les paramètres d'applications fournis le sont à titre guide

Contents:

Contenido:

Contenu:

Spreader Hardware (Actual size)

Accesorios para esparcidor (tamaño real)

Quincaillerie de l'épandeur (taille réelle)

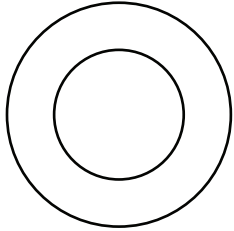

H-1 (X4)
Flat Washer



H-2
Cotter Pin



H-3
M5 x 35mm
Hex Bolt



H-4
M6 x 45mm
Hex Bolt



H-8
R-Pin



H-12
M4 x 10mm Screw

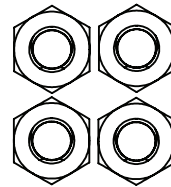

H-7
M6 x 1mm Nylock Nut



H-6
Locking Nut



H-9
Auger

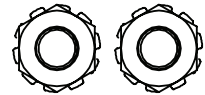

H-10
Locking Nut with
Tooth Washer

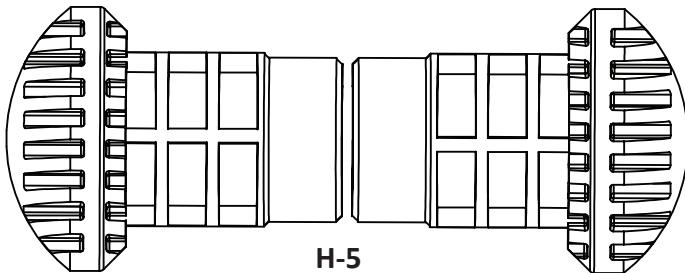

H-5
End Cap

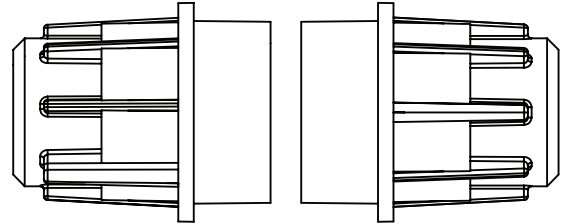

H-11
Bushing

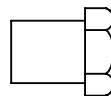

H-6
Auger Nut

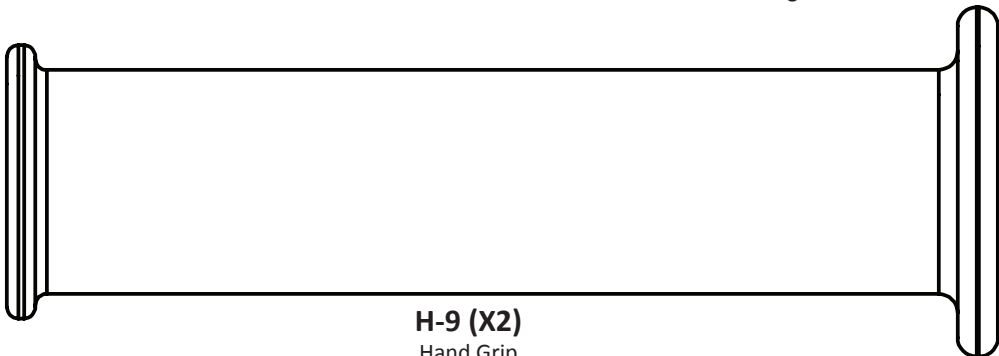

H-9 (X2)
Hand Grip

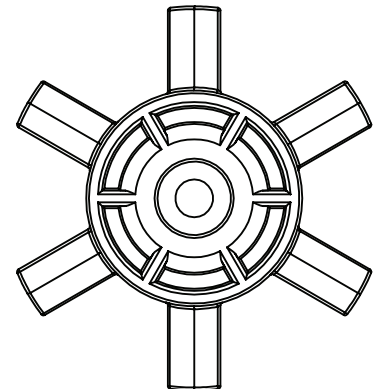

H-12
Auger

Note: Not all components shown may be needed on your model

Nota: Puede que no todos los componentes mostrados sean necesarios en su modelo.

Remarque : Il se peut que certains des composants montrés ne soient pas requis pour l'assemblage de votre modèle.

TOOLS NEEDED:
HERRAMIENTAS REQUERIDAS:
OUTILS REQUIS:

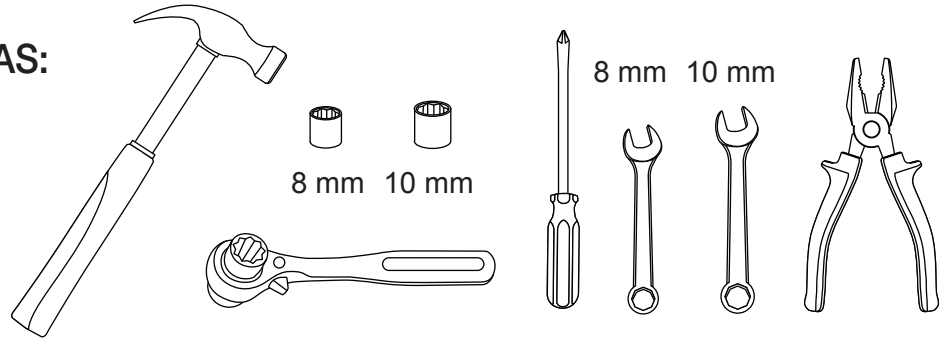

Spreader Components (Not Actual size)
Componentes de la esparcidor (no en tamaño real)
Composants de l'épandeur (taille non réelle)

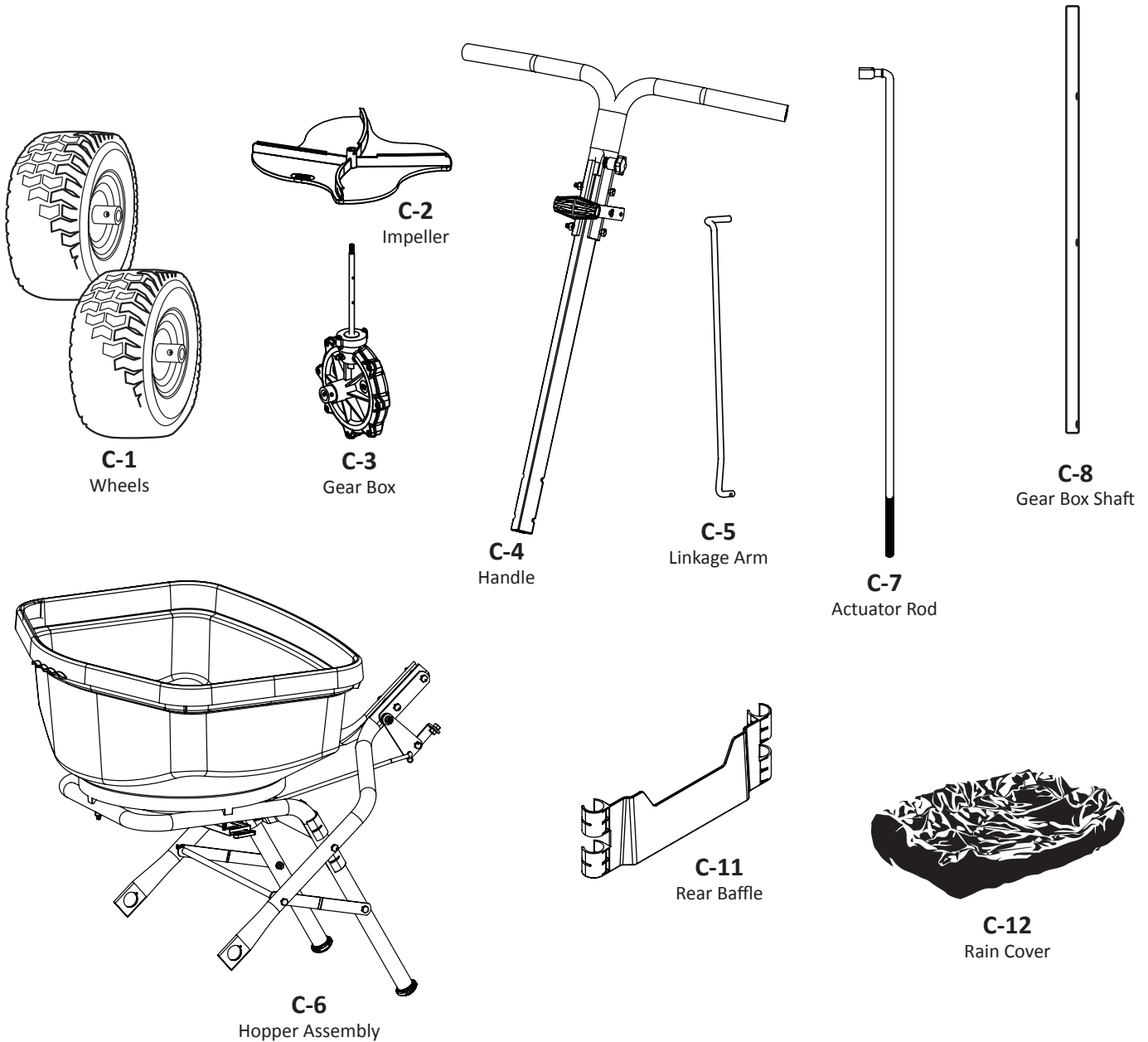

1

Handle Grip Assembly

Ensamble de la manija / Assemblage de la poignée

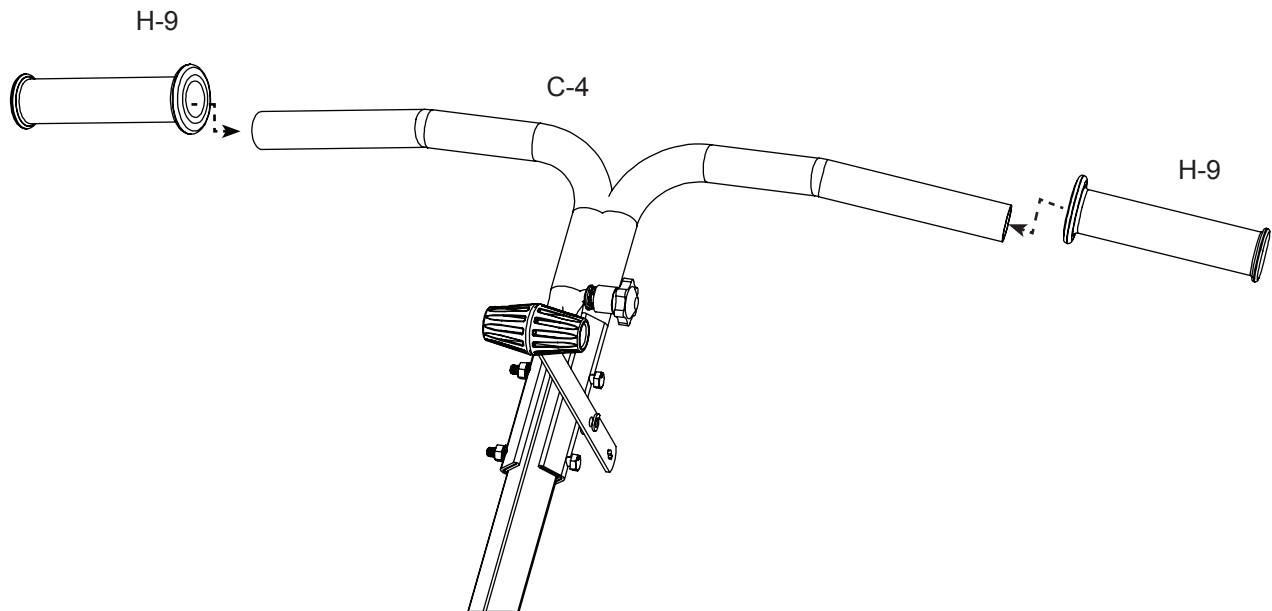

1.1

Note: Hopper not shown in drawing for clarity.

Nota: No se muestra la tolva en el dibujo para clarificar.

Remarque : La trémie n'est pas montrée sur le schéma pour plus de clarté.

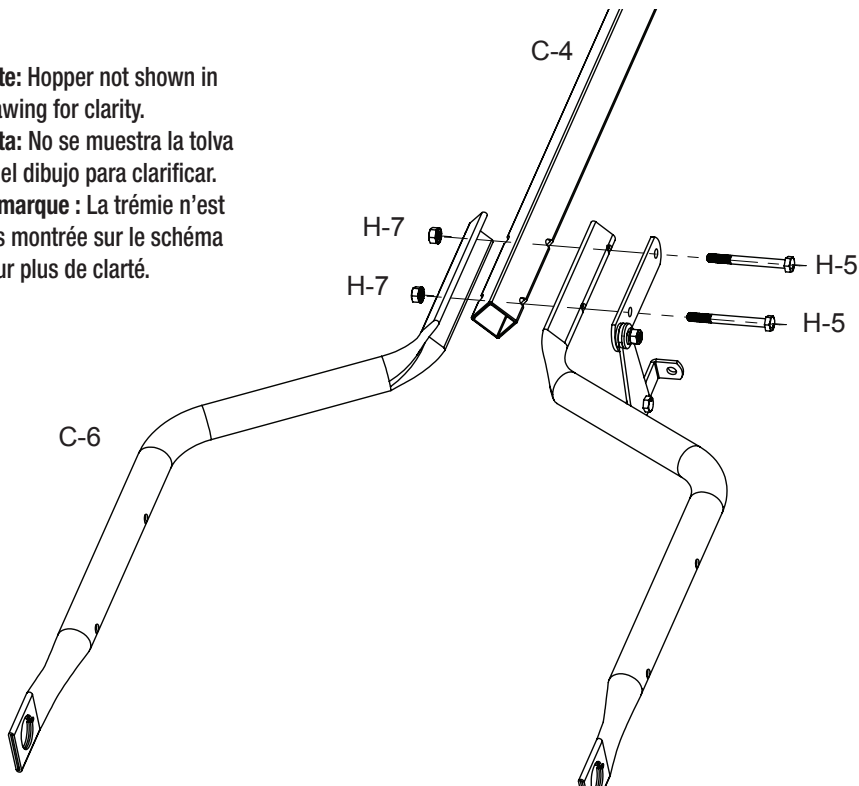

Loosen nuts and bolts (H-5), place C-4 into C-6 assembly. Assemble nuts (H-7) on existing bolts (H-5).

Afloje las tuercas y los pernos (H-5), coloque C-4 en el ensamblaje C-6. Ensamble nuevamente las tuercas (H-7) y los pernos (H-5).

Desserrez les écrous et les boulons (H-5), montez C-4 dans l'assemblage C-6. Assemblez les écrous (H-7) et les boulons (H-5).

2

Assemble Impeller to Gear Box

Sujete el impulsor a la caja de velocidades / Assembler l'impulseur au boîtier d'engrenage

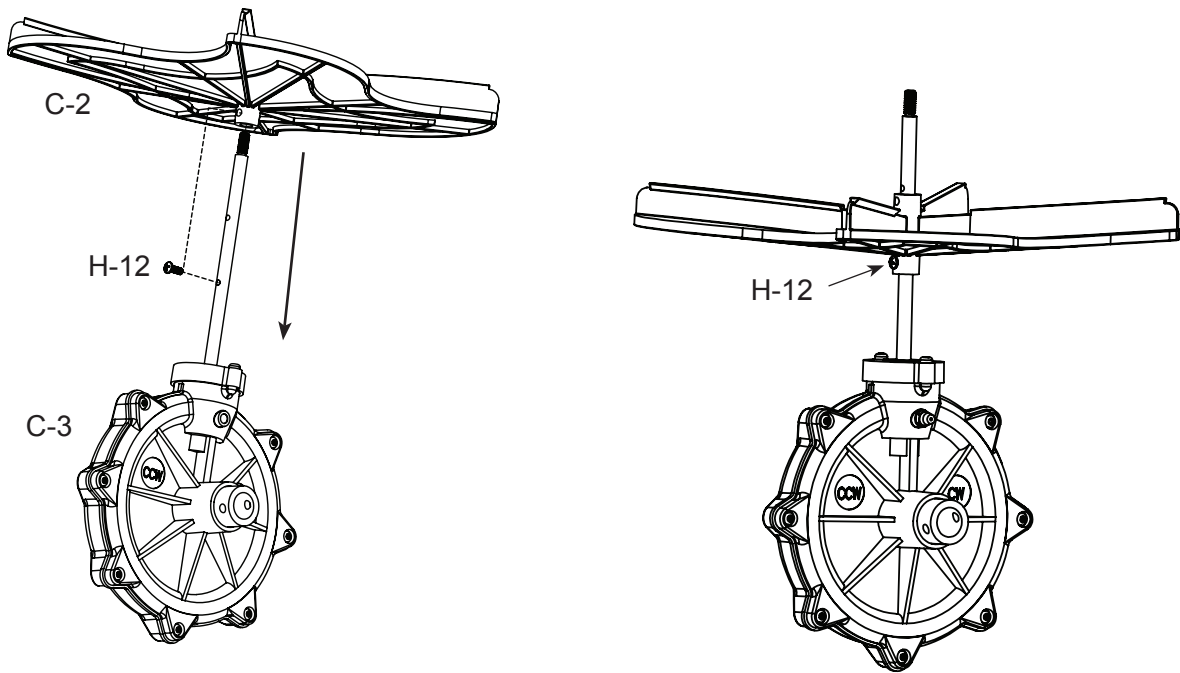

3

Assemble Impeller to Gear Box Shaft

Sujete el impulsor al eje de la caja de velocidades / Assembler l'impulseur sur l'arbre du boîtier d'engrenage

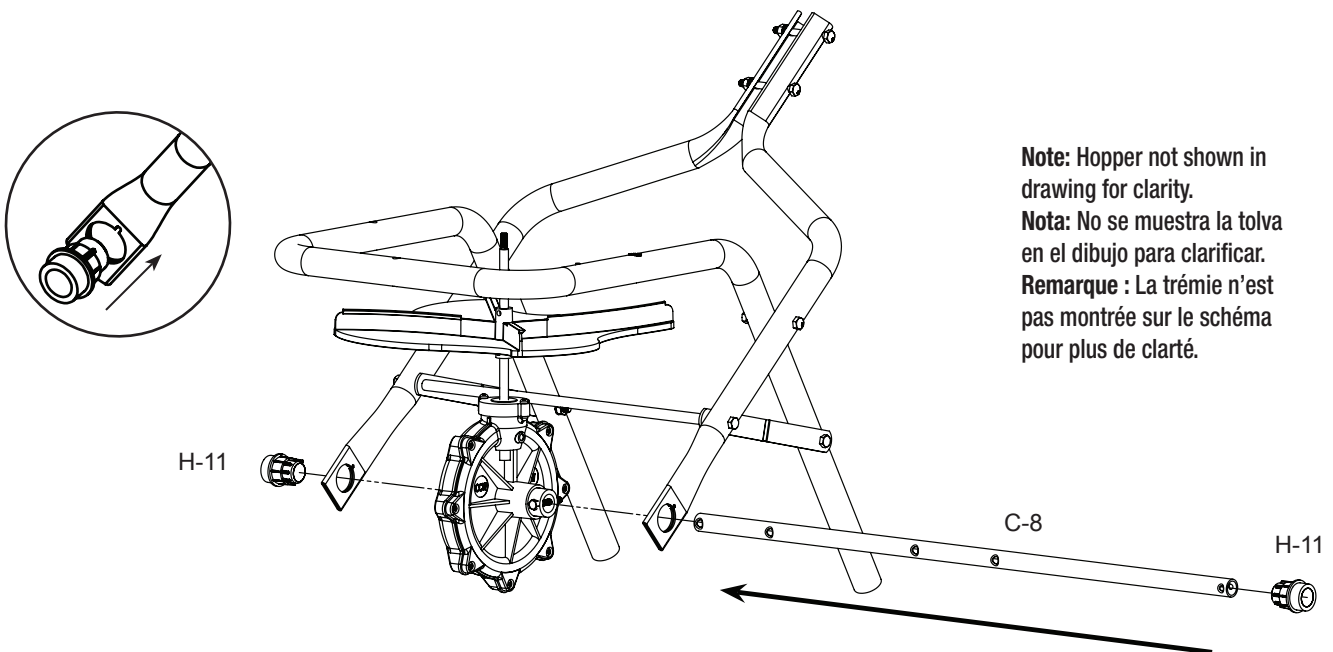

IMPORTANT: Gearbox runs counterclockwise when viewed from above. Orientated as shown in diagram.

¡IMPORTANTE! La caja de velocidades funciona en sentido contrario a las agujas del reloj cuando se mira desde arriba. Se orienta como se muestra en el diagrama.

IMPORTANT : Le boîtier d'engrenage tourne en sens antihoraire lorsque vu du dessus. Orienté comme il est indiqué dans le schéma.

3.1

Counterclockwise marking on the impeller.
Indicación en sentido contrario a las agujas del reloj en el impulsor.
Sens antihoraire marqué sur l'arbre.

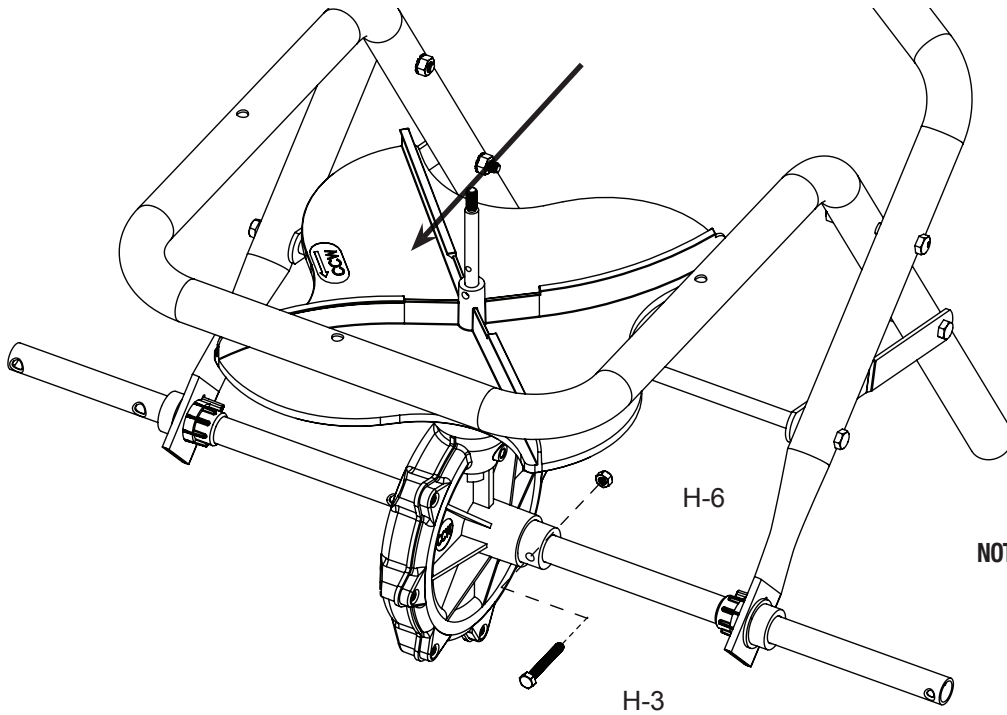

4

Assemble wheels

Ensamble las ruedas / Assembler les roues

Note: Hopper not shown in drawing for clarity.

Nota: No se muestra la tolva en el dibujo para clarificar.

Remarque : La trémie n'est pas montrée sur le schéma pour plus de clarté.

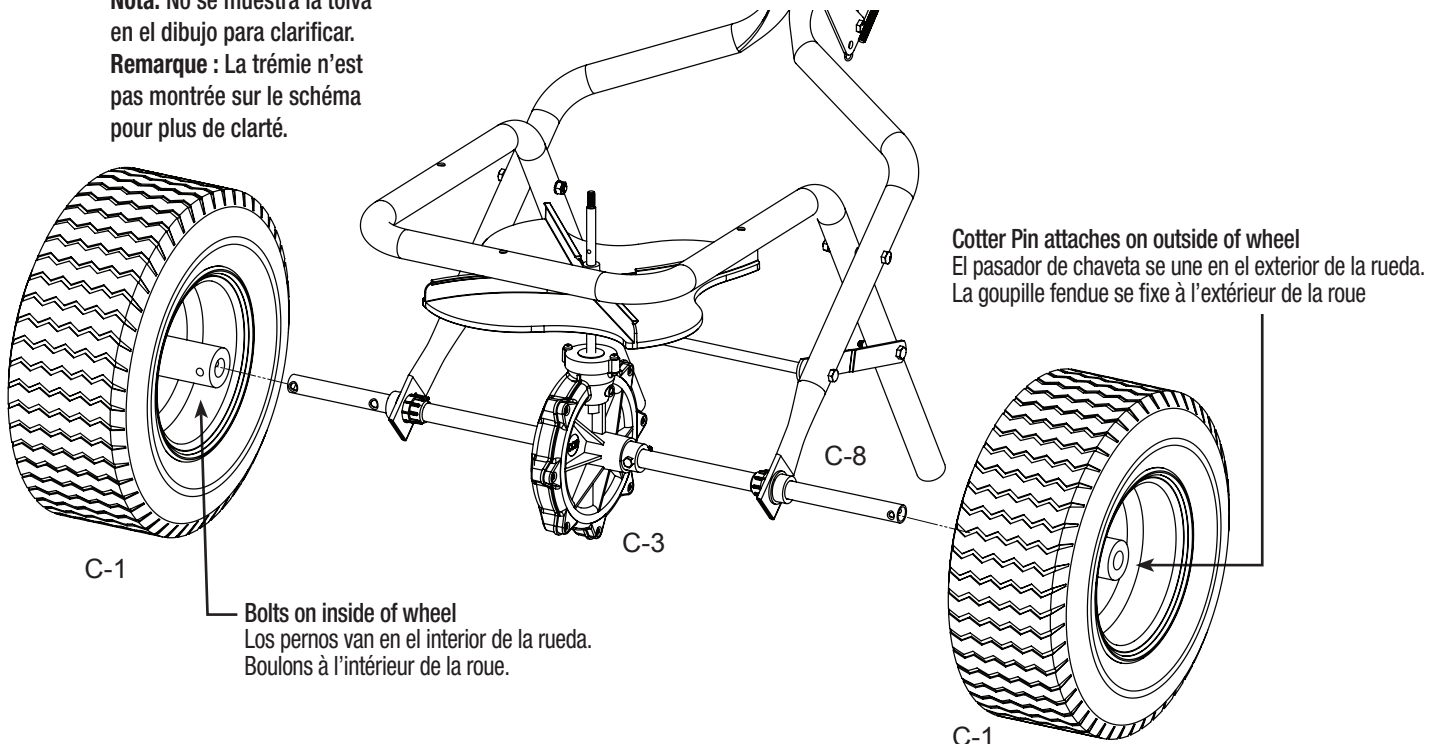

4.1

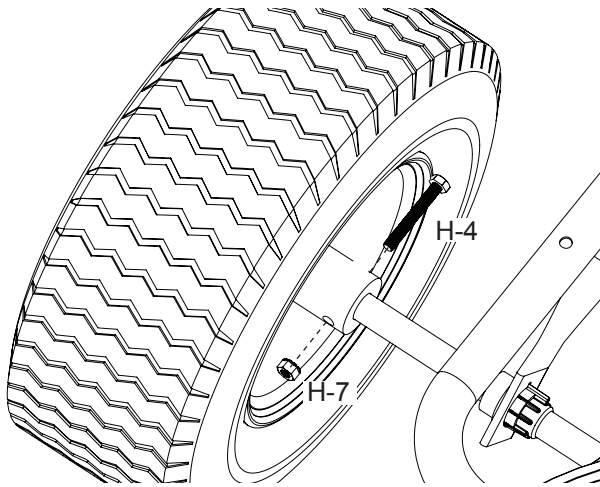

Bolt installation on inside of wheel
 Instalación de los pernos en el interior de la rueda.
 Installation du boulon à l'intérieur de la roue

4.2

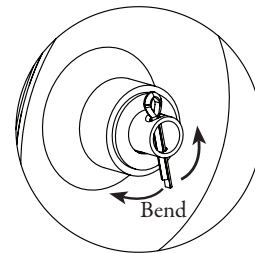
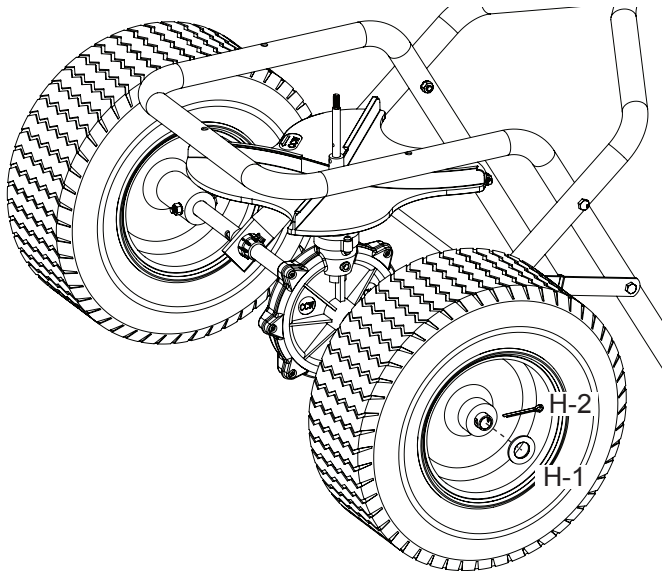

Cotter pin installation on outside of wheel
 Instalación del pasador de chaveta en el exterior de la rueda.
 Installation de la goupille fendue à l'extérieur de la roue

5

Assemble Auger

Ensamble el tornillo sin fin / Assembler la vis d'alimentation

Choose flat auger (H-9) for General turf applications.

Seleccione el barreno plano (H-9) para aplicaciones generales con césped.

Choisissez une vis d'alimentation plate (H-9) pour des applications de gazon à usage général.

- | | | |
|-------------------------|----------------------------|--------------------------------|
| • Fertilizers | • Fertilizantes | • Fertilisants |
| • Herbicides | • Herbicidas | • Herbicides |
| • Pesticides | • Pesticidas | • Pesticides |
| • Grass Seed | • Semillas de césped | • Semences d'herbe |
| • Free-Flowing Material | • Material con flujo libre | • Matière s'écoulant librement |

Thread auger (H-9) clockwise onto impeller shaft (C-3) and secure with H-10 nut.

Atornille el barreno (H-9) en sentido de las agujas del reloj en el eje del impulsor (C-3) y fijelo con la tuerca H-10.

Vissez la vis d'alimentation (H-9) en sens horaire dans l'arbre de l'impulseur (C-3) et fixer avec un écrou H-10.

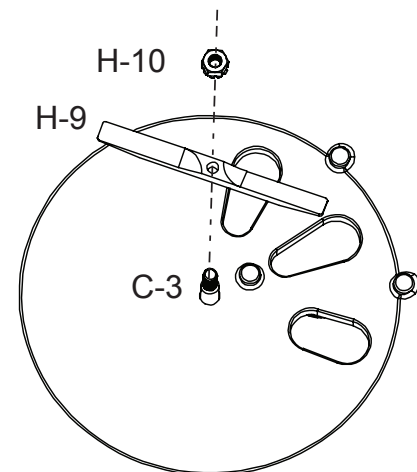

5.1

Choose spiked auger for use with dense materials that have a tendency to clump or have a higher moisture content.

Seleccione el barreno con púas para usarlo con materiales densos que tengan tendencia a aglutinarse o que tengan un contenido de humedad más alto.

Choisissez une vis d'alimentation pointue pour une utilisation avec des matières denses qui ont une tendance à faire des mottes ou à avoir une teneur en humidité plus élevée.

- Ice Melt - Calcium Chloride
- Derretidor de hielo - Cloruro de calcio
- Fonte de glace – Chlorure de calcium
- Lawn Mineral Supplement
- Suplementos minerales para jardín
- Compléments minéraux pour pelouse

CAUTION: This spreader is NOT recommended for use with rock salt.

PRECAUCIÓN: NO se recomienda usar esta esparcidora con sal de roca.

ATTENTION : Cet épandeur n'est PAS recommandé pour une utilisation avec du sel gemme.

Thread auger (H-12) clockwise onto impeller shaft (C-3). Insert auger nut (H-6).

Tighten with 10 mm wrench. Do not over tighten.

Atornille el barreno (H-12) en sentido de las agujas del reloj en el eje del impulsor (C-3). Inserte la tuerca de barreno (H-6). Apriete con una llave de 10 mm. No apriete demasiado.

Vissez la vis d'alimentation (H-12) en sens horaire dans l'arbre de l'impulseur (C-3). Insérez un écrou de vis d'alimentation (H-6). Serrez à l'aide d'une clef de 10 mm. Ne serrez pas trop.

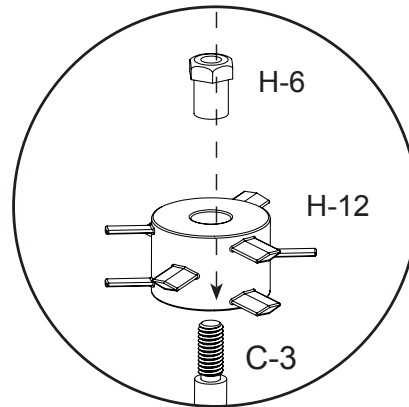

6

Assemble Gate Linkage

Sujete la unión de la compuerta / Assembler la tringlerie de la vanne

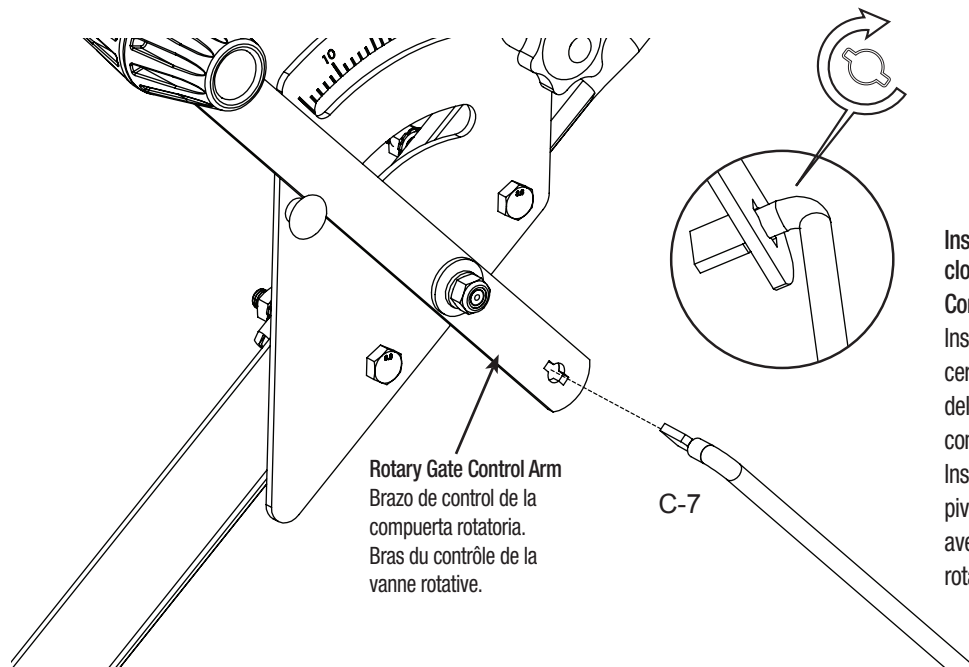

Insert C-7 into key hole. Rotate clockwise to align with Rotary Gate Control Arm.

Insérte C-7 en el agujero con forma de cerradura. Rote en sentido de las agujas del reloj para alinear con el brazo de control de la compuerta rotatoria.

Insérez C-7 dans le trou de la clé. Faites pivoter en sens horaire pour aligner avec le bras du contrôle de la vanne rotative.

6.1

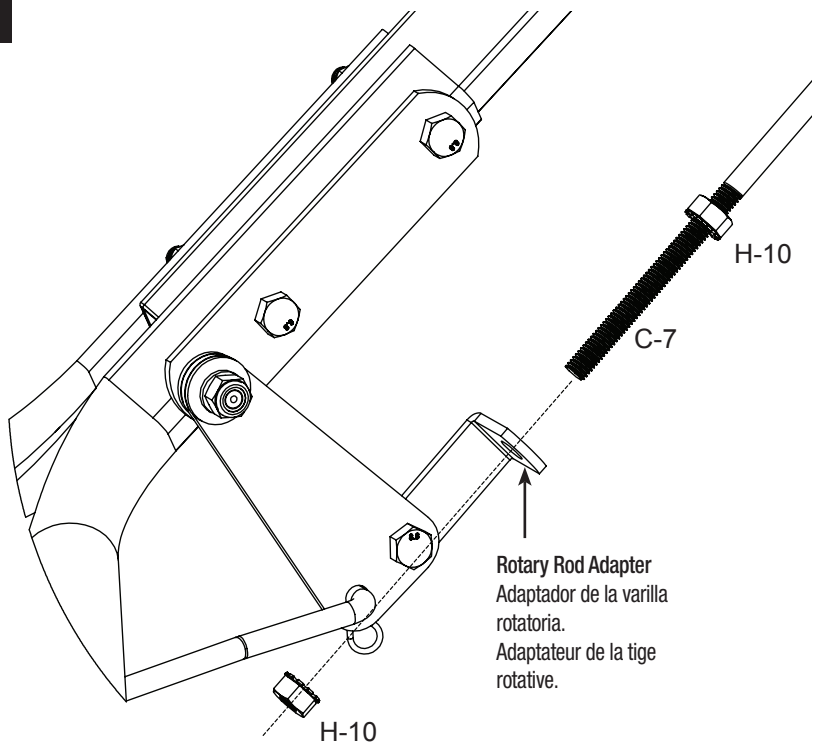

Assemble first H-10 nut to linkage C-7 as shown. Assemble C-7 to Rotary Rod Adapter as shown. Attach second H-10 nut to C-7 linkage.

Coloque la primera tuerca H-7 en la unión C-7 como se muestra. Ensamble C-7 al adaptador de la varilla rotatoria como se muestra. Coloque la segunda tuerca H-10 en la unión C-7.

Assemblez d'abord l'écrou H-10 à la tringlerie C-7, comme il est indiqué. Assemblez C-7 à l'adaptateur de la tige rotative, comme il est indiqué. Attachez le second écrou H-10 à la tringlerie C-7.

Loosely attach nut (H-10) to linkage (C-7). Keep loose for adjustment later.

Una la tuerca (H-10) a la unión (C-7) sin mayor precisión. Manténgala floja para ajustarla posteriormente.

Fixer lâchement l'écrou (H-10) à la tringlerie (C-7). Laisser lâche pour un ajustement ultérieur.

6.2

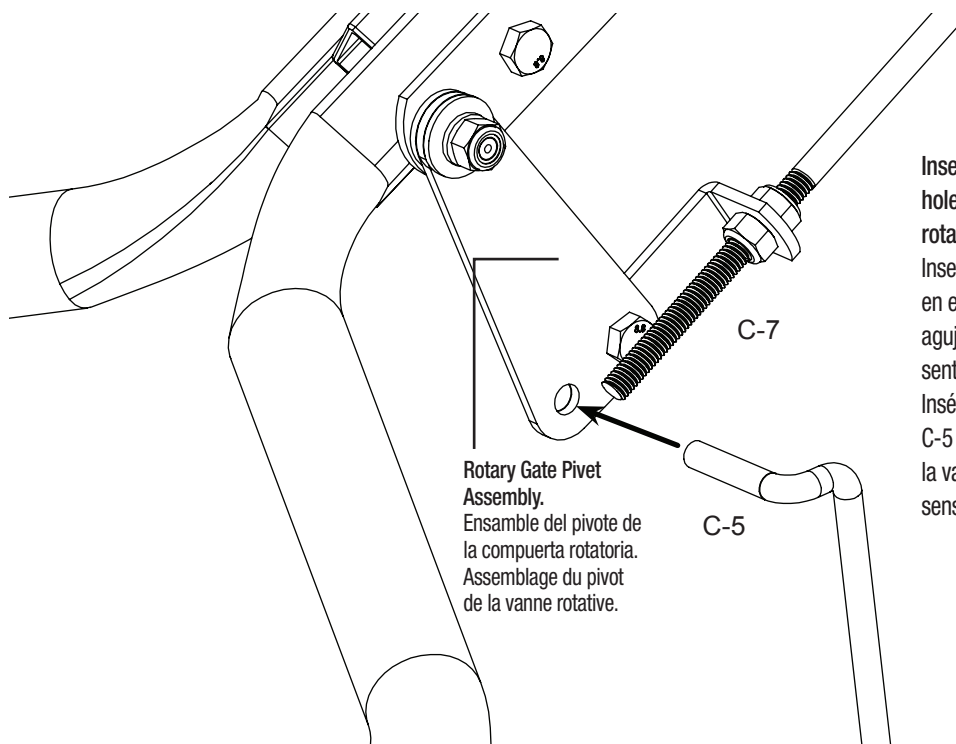

Insert C-5 linkage arm into hole Rotary Gate Pivot and rotate clockwise.

Inserte el brazo de unión C-5 en el pivote de la compuerta del agujero rotatorio y gírelo en el sentido de las agujas del reloj. Insérez le bras de tringlerie C-5 dans l'orifice du pivot de la vanne rotative et tournez en sens horaire.

6.3

Insert C-5 linkage arm into hole in rotary gate below hopper.
Inserte el brazo de la unión C-5 en el agujero en la compuerta giratoria bajo la tolvilla.
Insérer le bras de tringlerie C-5 dans le trou de la vanne rotative sous la trémie.

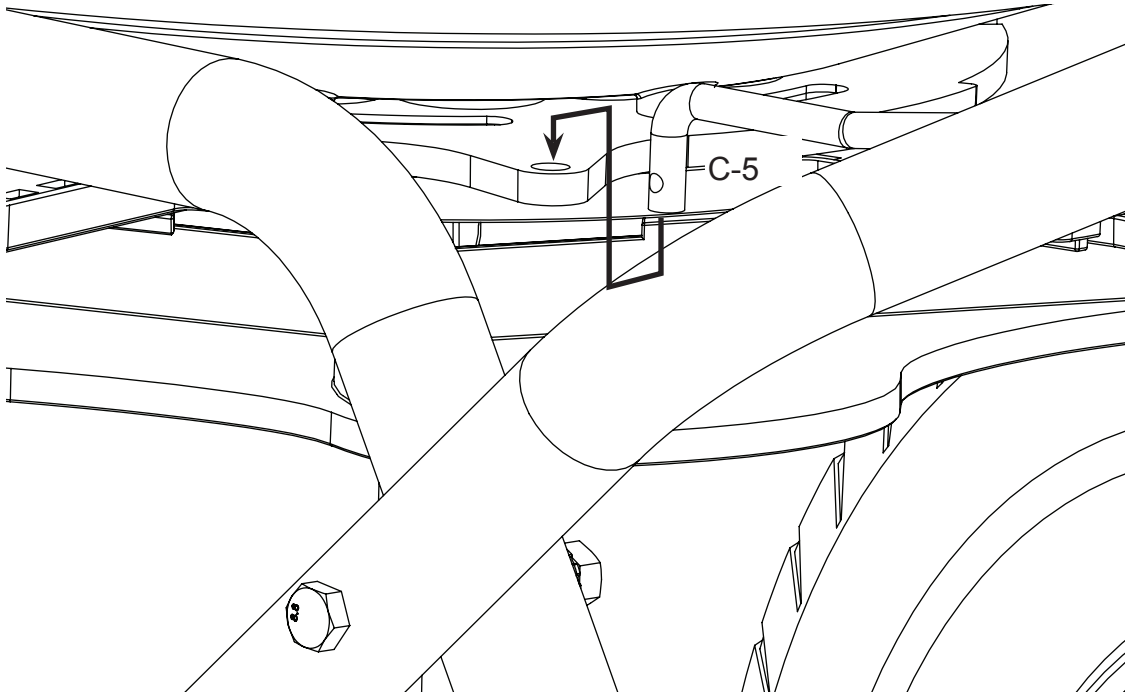

6.4

Attach R-Pin (H-8)
Sujete el pasador R (H-8)
Fixer la goupille en « R » (H-8)

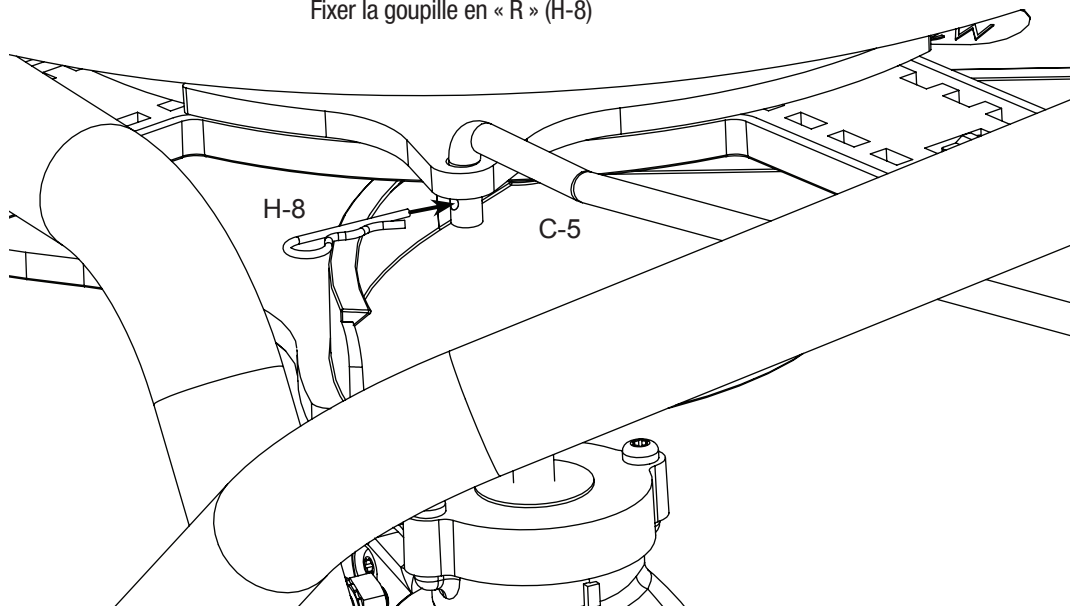

7

Attach Rear Baffle (snap onto frame)

Sujete el deflector trasero (encájelo en el marco) / Fixer le déflecteur arrière (s'enclique sur le cadre)

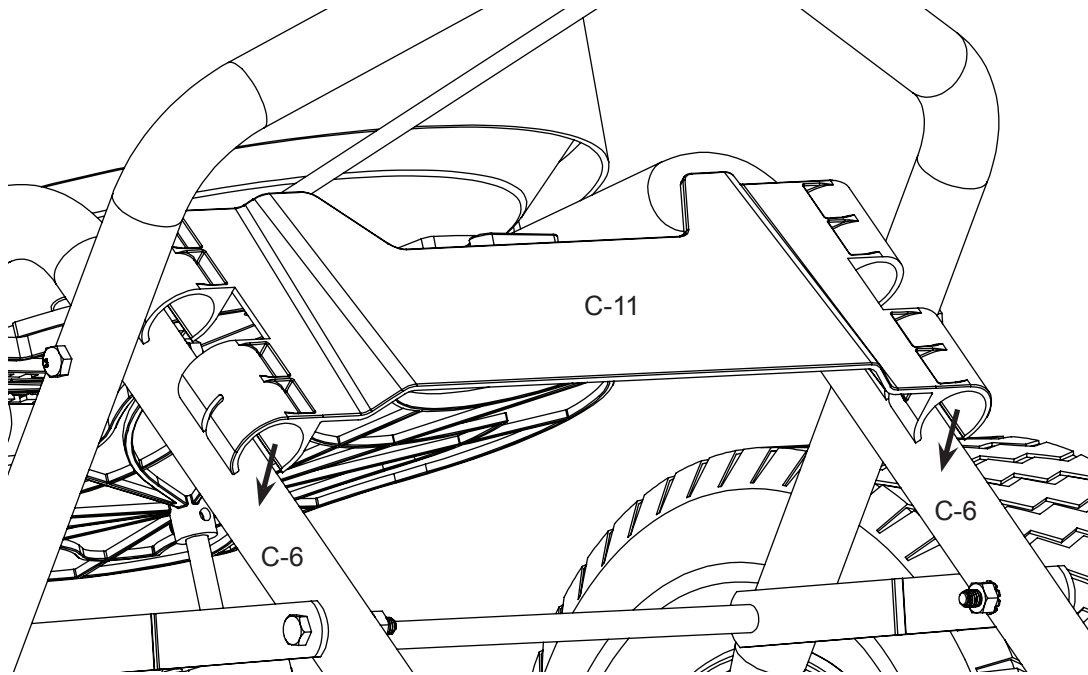

Snap rear baffle (C-11) onto both frame legs (C-6) as shown with flat edge towards ground.

Encaje el deflector trasero (C-11) en ambos extremos del marco (C-6) como se muestra con el extremo plano hacia el suelo.

Encliquer le déflecteur arrière (C-11) sur les deux pattes du cadre (C-6), comme il est montré, le bord plat orienté vers le sol.

8

Assemble Adjustable Feet

Ensamble el pie ajustable / Assembler pieds ajustables

Go back and tighten all hardware that was left loose.

Regrese y apriete todos los sujetadores que quedaron flojos.

Revenez pour serrer tout le matériel laissé desserré.

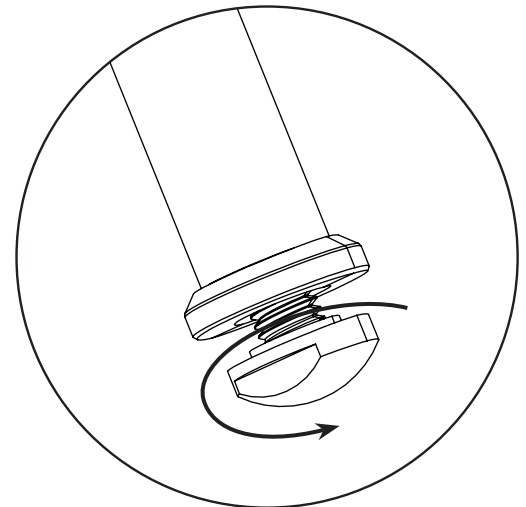
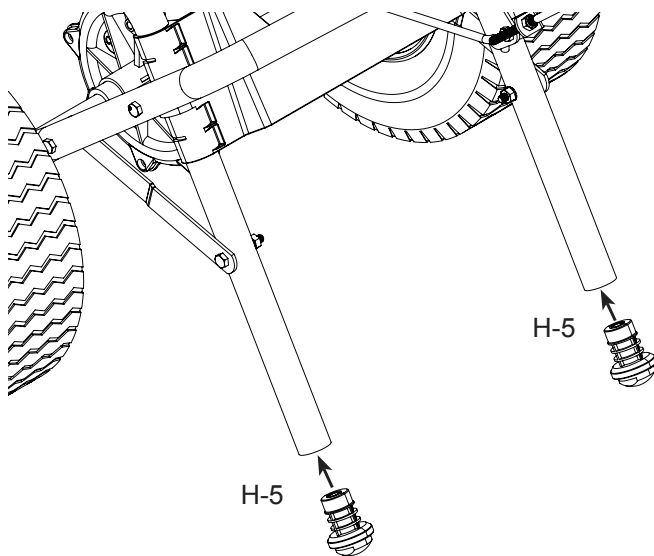

Use hammer to tap in adjustable feet (H-5). Use adjustable feet to level spreader on flat surface.

Use un martillo para insertar los pies ajustables (H-5). Utilice el pie ajustable para nivelar el esparcidor en una superficie plana.

Utilise le marteau pour enfoncer les pieds réglables (H-5). Utiliser pieds ajustables pour niveller l'épandeur sur une surface plane.

9

Adjust Gate Control

Ajuste el control de la compuerta / Ajuster le contrôle de la vanne

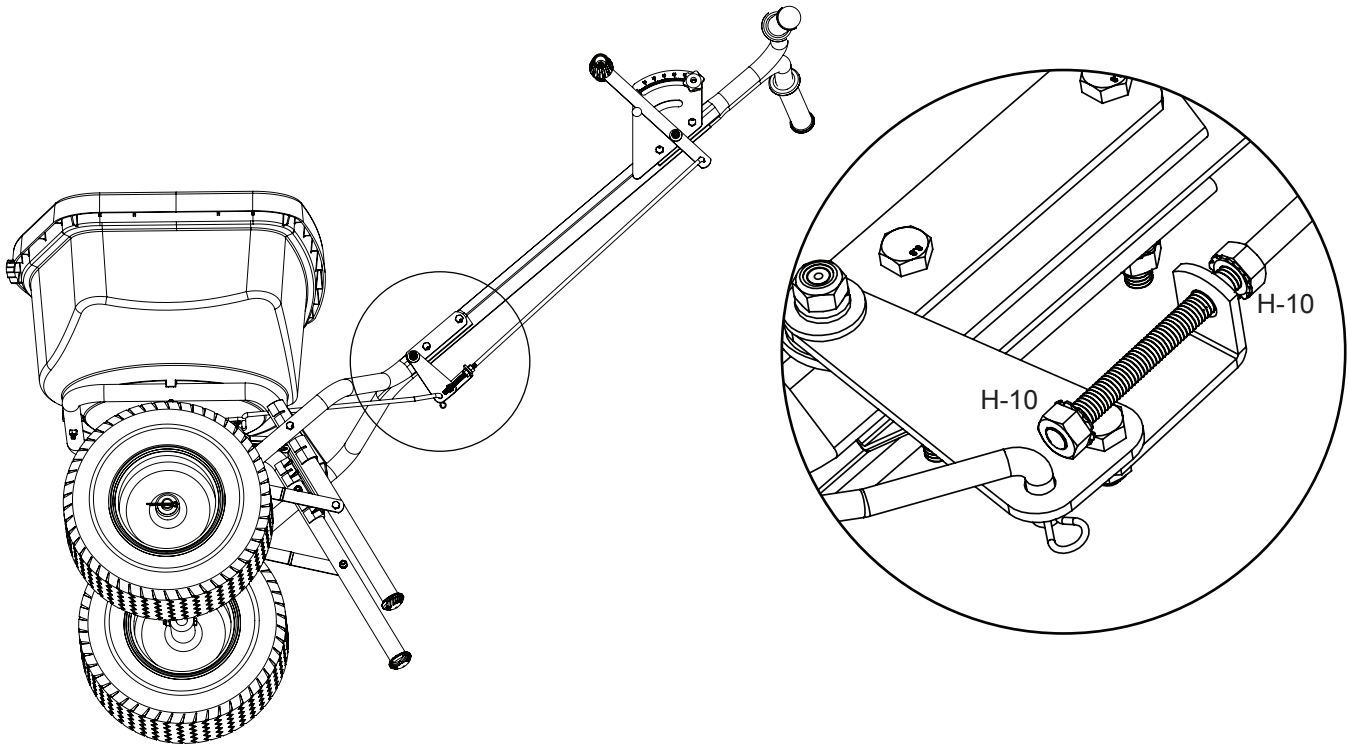

Before setting gate, make sure the Hex Nuts (H-10) are positioned as shown.

Antes de instalar la compuerta, asegúrese de que las tuercas hexagonales (H-10) estén en posición como se muestra.

Avant de régler la vanne, s'assurer que les écrous hexagonaux (H-10) sont positionnés comme il est montré.

9.1

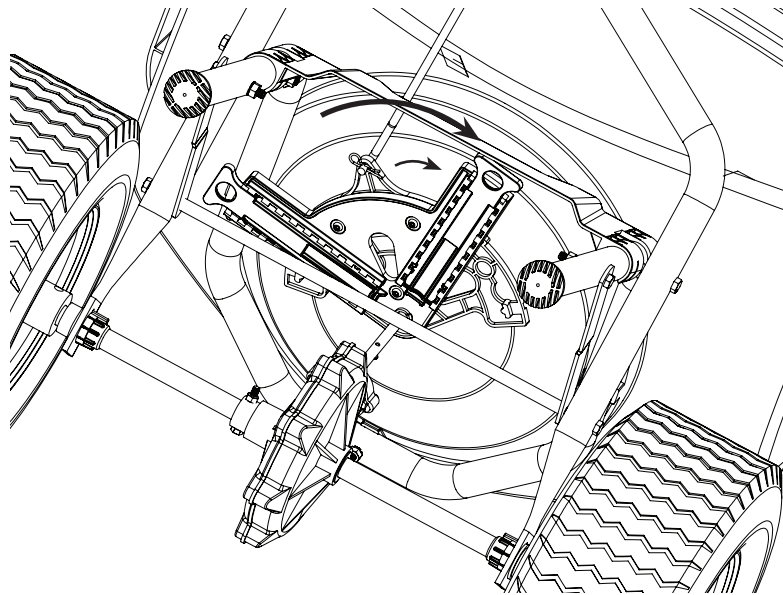

Turn rotary gate (part of hopper assembly) clockwise until gate is completely closed. Note: Impeller (C-2) not shown in drawing for clarity.

Gire la compuerta rotatoria (parte del conjunto de tolillas) en sentido de las agujas del reloj hasta que la compuerta esté completamente cerrada. Nota: No se muestra el impulsor (C-2) en el dibujo para clarificar.

Tourner la vanne rotative (partie de l'assemblage de la trémie) en sens horaire jusqu'à ce que la vanne soit entièrement fermée. Remarque : L'impulseur (C-2) n'est pas montré sur le schéma pour plus de clarté.

9.2

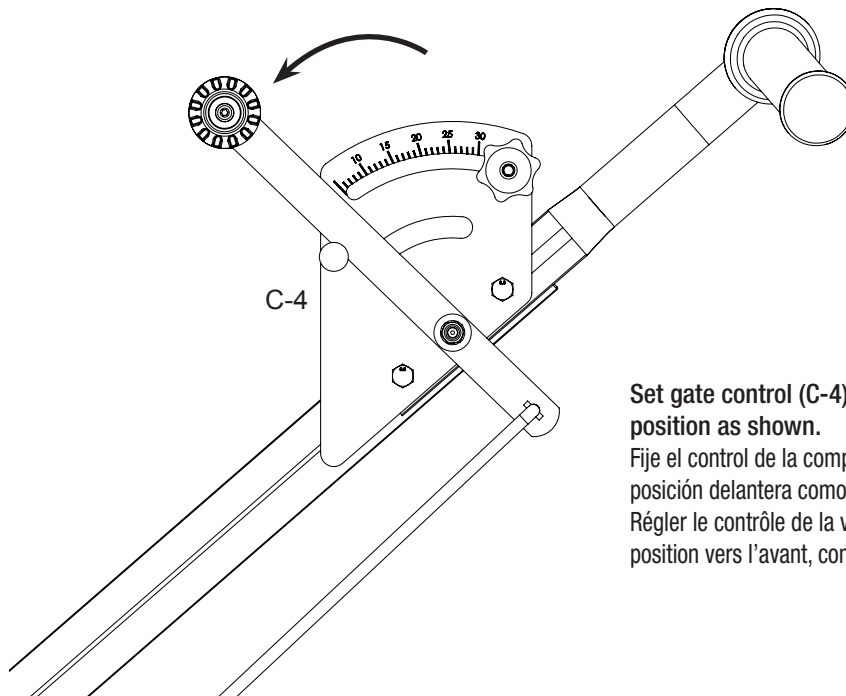

Set gate control (C-4) in forward position as shown.

Fije el control de la compuerta (C-4) en posición delantera como se muestra.

Régler le contrôle de la vanne (C-4) en position vers l'avant, comme il est montré.

9.3

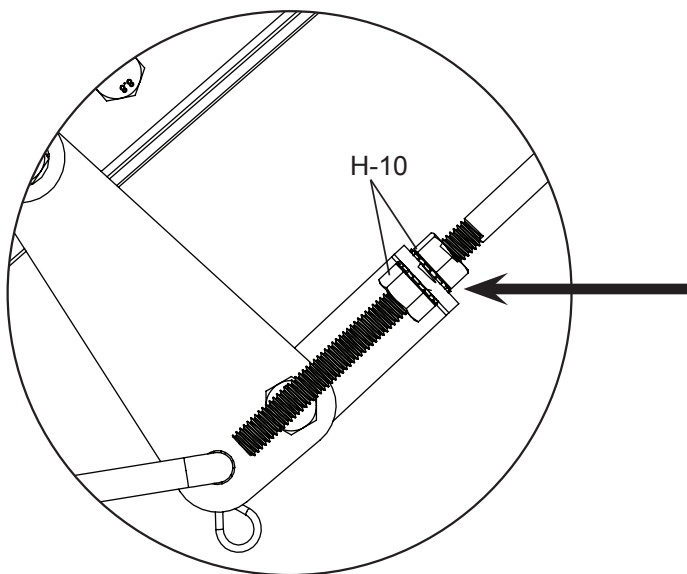

With the rotary gate closed and the gate control arm in the closed position, tighten the Hex nuts to the bracket as shown.

Con la compuerta rotatoria cerrada y el brazo de control de la compuerta en posición cerrada, apriete las tuercas hexagonales al soporte como se muestra.

Alors que la vanne rotative est fermée et que le contrôle de la vanne est en position fermée, serrer les écrous hexagonaux sur le support, comme il est montré.

10

Adjust Spread Pattern Using Left and Right Gate

Ajuste el patrón de distribución utilizando las compuertas derecha e izquierda / Ajuster le motif d'épandage en utilisant la vanne de gauche et de droite

Full Spread Pattern

Patrón de distribución completa

Motif d'épandage entier

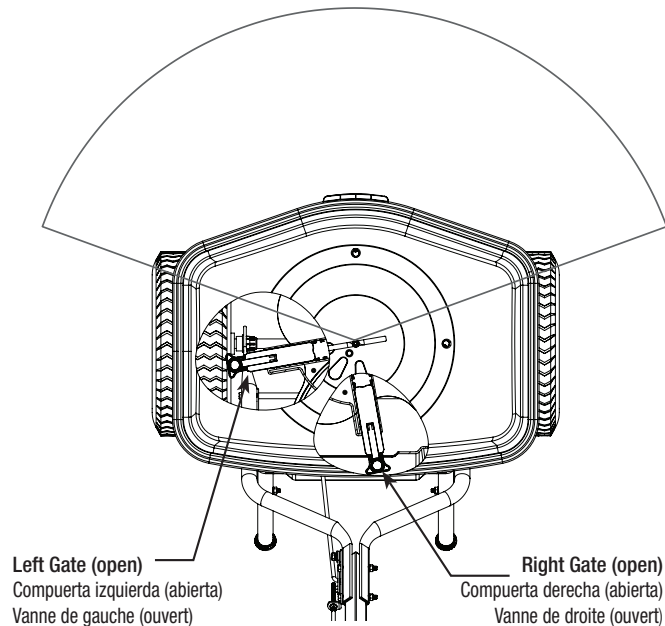

Left Spread Pattern

Patrón de distribución a la izquierda

Motif d'épandage à gauche

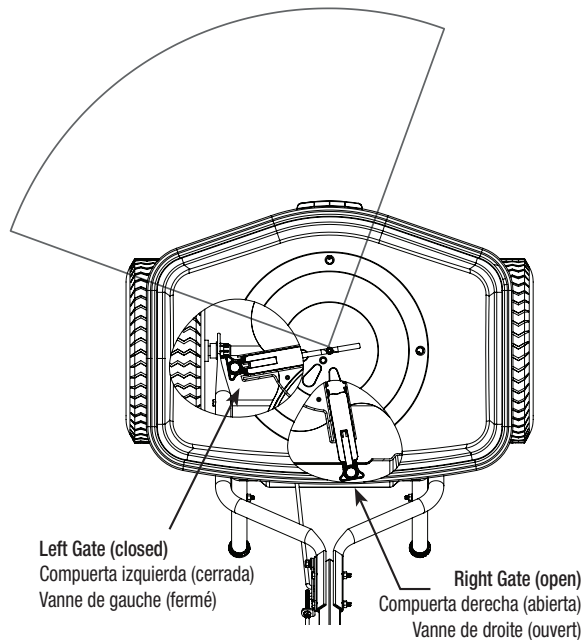

Right Spread Pattern

Patrón de distribución a la derecha

Motif d'épandage à droite

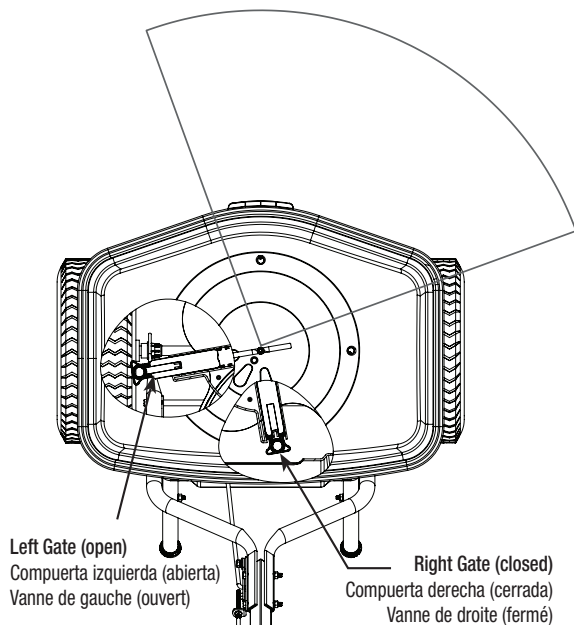

Narrow (centered) Spread Pattern

Patrón de distribución estrecho (centrado)

Motif d'épandage étroit (centré)

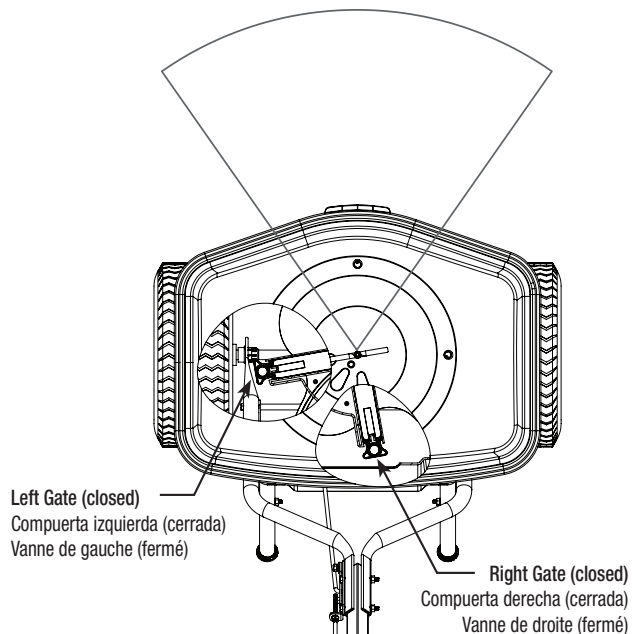

STORAGE AND MAINTENANCE

- Use garden hose to wash down the spreader after each use.
- Be careful not to direct the spray directly onto the gear box
- It is recommended that you **DO NOT** use a power washer on your spreader.

ALMACENAJE Y MANTENIMIENTO

- Utilice la manguera de jardín para lavar la esparcidora después de cada uso.
- Tenga cuidado de no dirigir el rociador directamente a la caja de velocidades
- Se recomienda que **NO** utilice una lavadora a presión en su esparcidora.

ENTREPOSAGE ET ENTRETIEN

- Utiliser un boyau de jardin pour laver l'épandeur après chaque utilisation.
- Faites attention à ne pas diriger le jet directement sur le boîtier d'engrenage
- Il est recommandé de **NE PAS** utiliser une laveuse à pression sur votre épandeur.

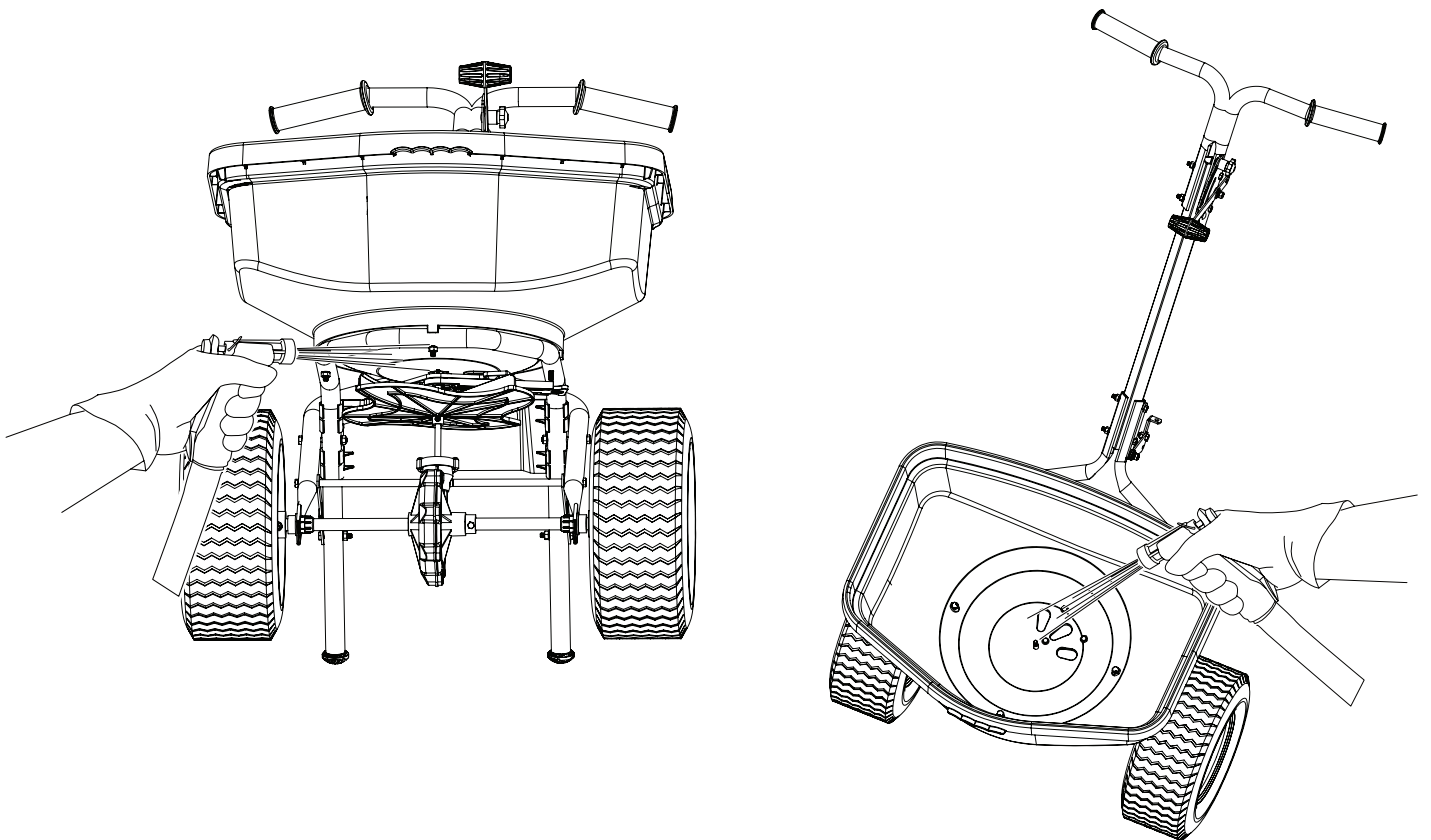

Replacement Parts / Partes de repuesto / Pièces de rechange

ITEM NO.	PART NUMBER	DESCRIPTION
1	91210	Gear Box Assembly / Conjunto de la caja de engranes / Ensemble de la boîte de'engrenages
2	91211	Drive shaft w/2 bushings / Fletcha de transmisión c/2 coninetes / Arbre d'entraînement avec 2 douilles
3	91212	Gate Control Assembly, Zinc / Conjunto del control de la compuerta / Ensemble du contrôle de la vanne
4	91213	Impeller & Securing Screw Assembly / Ensemble de tornillos de propulsión y fijación / Assemblage de l'impulseur et de la vis de blocage
5	91215	(1) RB-80 Tire & Rim Assembly 12"/ (1) RB-80 Ensemble de llanta y rin de 12"/ (1) Ensemble jante et pneu RB-80 de 12 po
6	91216	Handle Grips (2)/ Cubiertas de manijas (2)/ Poignées (2)
7	91217	Hardware Blister, Zinc / Bolsa de herrajes / Sac de matériel
8	91218	Rain Cover / Cubierta para lluvia / Couverture protectrice contre la pluie
9	91219	Auger & Lock Nut Assembly/ Ensemble de barreno y tuerca de bloqueo/ Assemblage de la vis sans fin et de l'écrou de blocage
10	91220	Rear Baffle / Baffle posterior / Cloison arrière

ITEMS NOT SHOWN

ITEM 7: 91217 (HARDWARE BLISTER)

ITEM 8: 91218 (RAIN COVER)

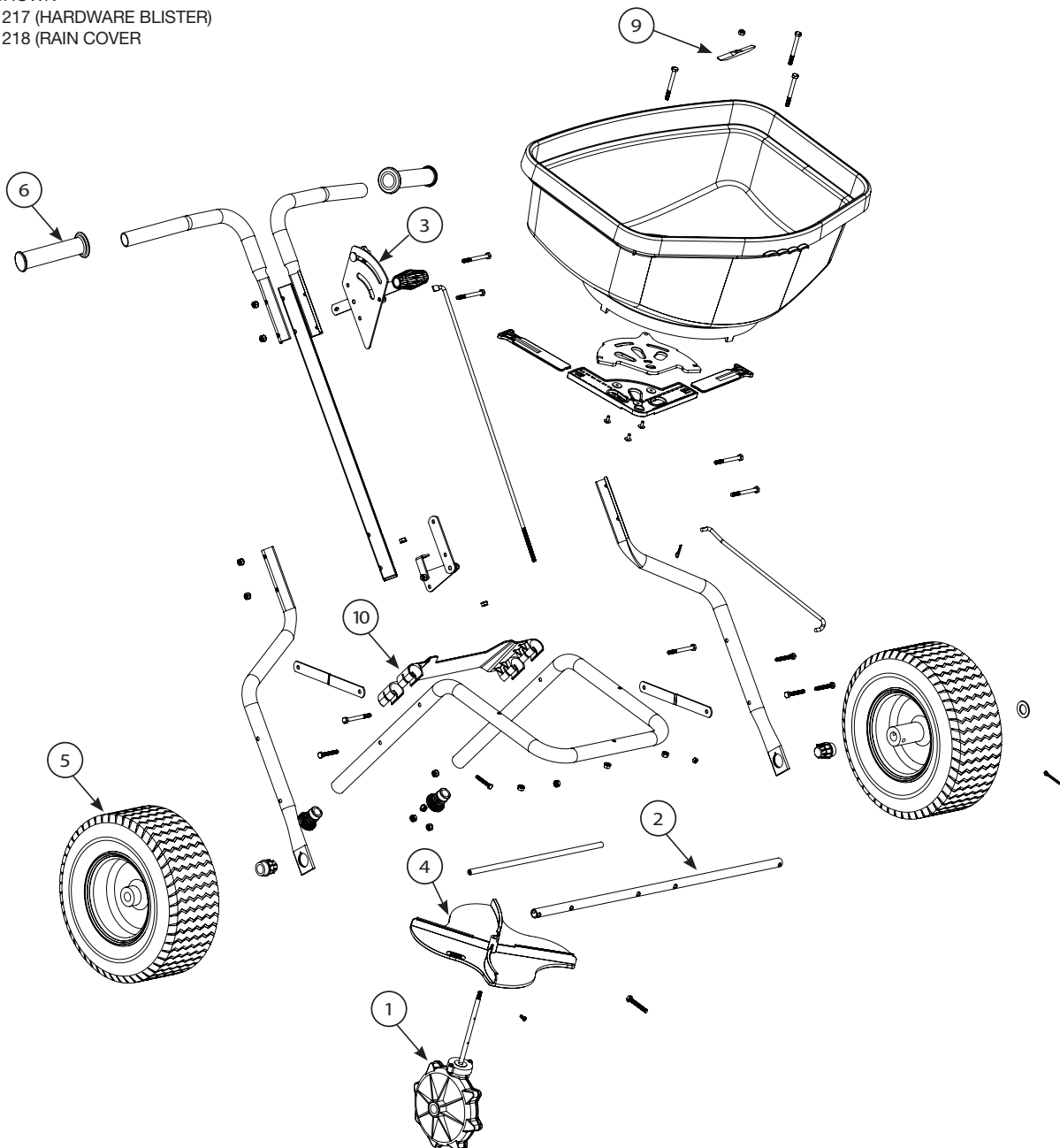

APPLICATION CHART / TABLA DE APLICACIÓN / TABLEAU D'APPLICATION

All Season Residential & Professional Push Spreader Application Conversion Chart

Table de conversión para la aplicación profesional y residencial del distribuidor de empuje para toda temporada
Tableau de conversion d'application pour épandeur à pousser résidentiel et professionnel toute saison

SCOTTS	2	2.5	3	3.25	3.5	4	4.75	5	5.5	6	7	8	9	10	11	12	13	14	15
ECHO	9	10	11	11	12	13	14	14	15	16	17	19	20	22	23	25	26	28	30
EARTHWAY	12	13	13.5	14	14.25	14.5	15	16	17	18	20	21	22	23	24	25	26	27	28
LESCO	4	5	5.5	6	7	8	9	9	9.5	10	11	12	13	14	15	16	17	18	19

All Season Residential & Professional General Application Guidelines

Aplicación general profesional & residencial para toda temporada directrices
Directives d'application générale résidentielle et professionnelle toute saison

Fine Control	1 - 10
Weed Control /Contol de hierba / Désherbage	11 - 12
Fertilizer / Fertilizante / Engrais	13 - 14
Grass Seed-Overseeding / Semilla de pasto-Sobresiembra / Graines de graminées-Sursemis	16 - 17
Grass Seed-New lawn / Semilla de pasto-Césped nuevo / Graines de graminées-Nouvelle pelouse	20 - 30
Salt & Ice-Melt / Sal y derretimiento / Sel et produit de déglçage	20 - 30

Sample Spread Pattern

Muestra del patrón de distribución
Modèle d'épandage type

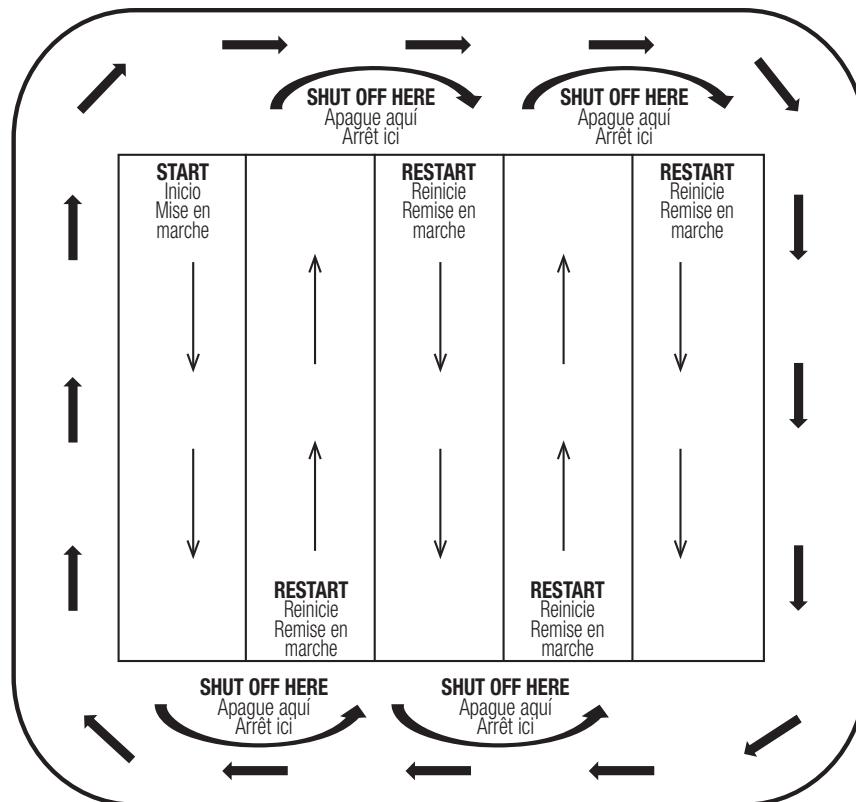



PRODUCT REGISTRATION CARD : TARJETA DE REGISTRO : CARTE D'ENREGISTREMENT DU PRODUIT

ONLINE OPTION: Register online and save a stamp! You will be alerted of product updates and/or be sent new ECHO product information and special offers. Simply go to: www.echo-usa.com

OPCIÓN POR INTERNET: ¡Regístrese en la página web y ahorre una estampilla! Le alertarán sobre actualizaciones del producto y/o se le enviara información sobre los nuevos productos ECHO y las ofertas especiales. Simplemente visite: www.echo-usa.com

OPTION EN LIGNE : Enregistrer en ligne et épargner un timbre! Vous serez informé sur les nouveaux produits ECHO et les mises à jour de produit ainsi que les offres spéciales. Simplement visitez le: www.echo-usa.com

Please Print : Por Favor Enscriba Con Letra De Molde : En Lettre Carré S.V.P.

Confidential: Information provided will not be shared or sold

Purchaser's Name : Nombre del Comprador : Nom de l'acheteur

Address : Dirección : Adresse

City : Ciudad : Ville State : Estado : Province Zip Code : Código Postal : Code Postal

E-Mail Address : Dirección De Correo Electrónico : Courrier Électronique

Phone Number : Número De Teléfono : Téléphone Date of Purchase : Fecha de la Compra : Date de l'achat

Where Purchased : Nombre del Almacén donde fue Comprado : Lieu d'achat

Model Number : Numero del Modelo : No. de modèle Serial Number : Numero de Serie : No. de série

Primary use of tool: Professional Homeowner Rental Equip.
Usó primario de la herramienta: Profesional Dueño de casa Alquiler
Usage principal : Professionnel Residential Location

Do you wish to receive periodic ECHO product information and special offers by e-mail? Yes No

¿Desea usted recibir información periódica y ofertas especiales por correo electrónico sobre el producto ECHO? Yes No

Souhaitez-vous recevoir périodiquement de l'information sur les produits ECHO et les offres spéciales par courrier électronique ? Oui Non

Did you visit the ECHO website before purchasing your product? Yes No

Visitó usted la página web ECHO antes de comprar su producto? Sí No

Avez-vous visité le site d'ECHO avant de procurer votre produit? Oui Non

What factor(s) most influenced your purchase?

- Performance Price Dealer
- Reliability Prior Experience Quality
- Friend/Family Brand Warranty

¿Qué factor(es) influenció más en su compra?

- Funcionamiento Precio Distribuidor
- Confiabilidad Experiencia Anterior Calidad
- Amigo/Familia Marca Garantía

Quel facteur (facteurs) vous a influencé le plus?

- Performance Prix Marchand
- Fiabilité Expérience Qualité
- Ami/Famille Marque Garantie

Registering your purchase enables us to contact you in the unlikely event of a service update or product recall and verifies your ownership in the event of loss. El registrar su compra nos permite estar en contacto con usted en caso de cualquier evento como el aviso de tiempo de servicio o la revocación del producto y verificación de propiedad en caso de robo o pérdida. L'enregistrement de votre achat nous permettra de vous contacter dans le cas improbable de modifications des instructions d'entretien ou de rappel du produit et vérifier que vous êtes le propriétaire en cas de vol ou de perte.

ECHO INC., 400 Oakwood Rd., Lake Zurich, IL 60047
1.800.432.3246 WWW.ECHO-USA.COM

X7572270206 02-2012

Your Serial number is located on the lower back of the hopper.

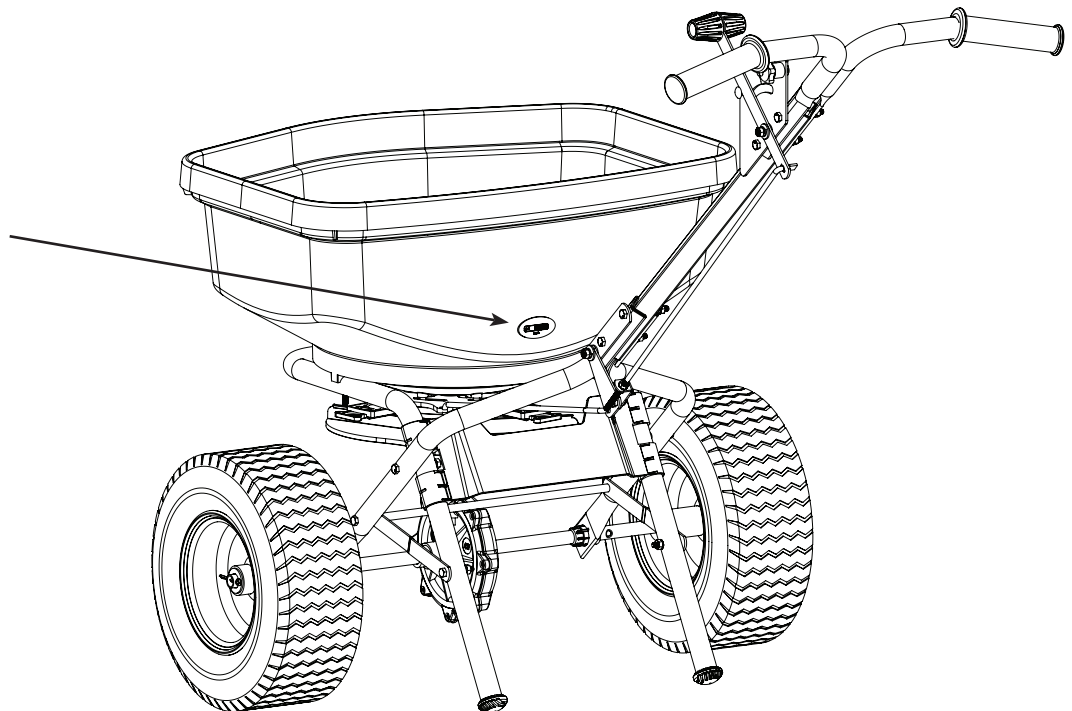

ECHO LIMITED WARRANTY STATEMENT FOR SPREADERS SOLD IN USA AND CANADA BEGINNING 01/01/2017

ECHO'S RESPONSIBILITY

ECHO Incorporated's Limited Warranty, provides to the original purchaser that this ECHO product is free from defects in material and workmanship. Under normal use and maintenance from date of purchase, ECHO agrees to repair or replace at ECHO's discretion, any defective product free of charge at any authorized ECHO servicing dealer within listed below application time periods, limitations and exclusions. **THIS LIMITED WARRANTY IS ONLY APPLICABLE TO ECHO PRODUCTS SOLD BY AUTHORIZED ECHO DEALERS. IT IS EXTENDED TO THE ORIGINAL PURCHASER ONLY, AND IS NOT TRANSFERABLE TO SUBSEQUENT OWNERS.** Repair parts and accessories replaced under this warranty are warranted only for the balance of the original unit or accessory warranty period. Any damage caused by improper installation or improper maintenance is not covered by this warranty. All parts or products replaced under warranty become the property of ECHO, Inc. For a list of Authorized ECHO Dealers refer to WWW.ECHO-USA.COM or call **1-800-432-3246**.

OWNER'S RESPONSIBILITY

To ensure trouble free warranty coverage it is important that you register your Echo equipment on-line at WWW.ECHO-USA.COM or by filling out the warranty registration card supplied with your unit. Registering your product confirms your warranty coverage and provides a direct link if we find it necessary to contact you.

The owner shall demonstrate reasonable care and use, and follow preventative maintenance and storage instructions as prescribed in the operator's manual. Should a product difficulty occur, you must, at your expense, deliver or ship your ECHO unit to an authorized ECHO servicing dealer for warranty repairs (within the applicable warranty period), and arrange for pick-up or return of your unit after the repairs have been made. For your nearest authorized ECHO servicing dealer, call ECHO's Dealer Referral Center, at 1-800-432-3246 or you can locate an ECHO servicing dealer at WWW.ECHO-USA.COM. Should you require assistance or have questions concerning ECHO's Warranty Statement, you can contact our Consumer Product Support Department at 1-800-673-1558 or contact us through the web at WWW.ECHO-USA.COM.

PRODUCT WARRANTY PERIOD

HOMEOWNER APPLICATION

• **5 YEAR WARRANTY** - All units for homeowner, or non-income producing use will be covered by this limited warranty for **five (5) years** from date of purchase.

EXCEPTIONS:

Damage caused by:

- Failure to follow Operator's Manual
- Failure to follow all chemical manufacturers' instructions included on their label or elsewhere
- Failure to follow Storing/Maintaining Your Spreader section in the Operator's Manual
- Wear items including but not limited to: Tires / Tire Inner Tubes. These items are covered for 90 days from date of purchase
- Any mis-use of product is not covered including but not limited to: using un-approved chemicals or parts, un-approved uses, exceeding hopper weight capacity, using damaged or missing units/parts during operation, or modifying your spreader in any manner.

COMMERCIAL APPLICATION

• **2 YEAR WARRANTY** - All other units for commercial, institutional, agricultural, industrial, or income producing use will be covered by this limited warranty for two (2) years from the date of purchase.

EXCEPTIONS:

Damage caused by:

- Failure to follow Operator's Manual
- Failure to follow all chemical manufacturers' instructions included on their label or elsewhere
- Failure to follow Storing/Maintaining Your Spreader section in the Operator's Manual
- Wear items including but not limited to: Tires / Tire Inner Tubes. These items are covered for 90 days from date of purchase
- Any mis-use of product is not covered including but not limited to: using un-approved chemicals or parts, un-approved uses, exceeding hopper weight capacity, using damaged or missing units/parts during operation, or modifying your spreader in any manner.

RENTAL APPLICATION - 90 DAYS WARRANTY

• Units for rental use will be covered against defects in material and workmanship for a period of 90 days from the date of purchase except for any of the above listed EXCEPTIONS.

ECHO does not offer an over the counter exchange program. Any ECHO product re-built other than by ECHO or sold through an unauthorized dealer, or an unauthorized outlet store, is sold without ECHO's limited warranty coverage. The ECHO Limited Warranty coverage is extended to the original purchaser only, and is not transferable. Repair parts and accessories replaced under this warranty are warranted only for the balance of the original unit or accessory warranty period. Any damage caused by improper installation or improper maintenance is not covered by this warranty. All parts or products replaced under warranty become the property of ECHO.

PURCHASED REPAIR PARTS AND ACCESSORIES

- 90-day homeowner, or non-income producing warranty except for any one of the above listed EXCEPTIONS
- 30-day commercial, institutional, agricultural, industrial, income producing, or rental application warranty except for any one of the above listed EXCEPTIONS

It is a dealer's and/or customer's responsibility to complete and return the warranty registration card supplied with your ECHO product or by visiting WWW.ECHO-USA.COM. Your receipt of purchase including date, model and serial number must be maintained and presented to an authorized ECHO servicing dealer for warranty service. Proof of purchase rests solely with the customer. Some states do not allow limitations on how long an implied warranty lasts, so the above limitations may not apply to you. Some states do not allow the exclusion or limitation of incidental or consequential damages, so you may also have other specific legal rights which vary from state to state. This limited warranty is given by ECHO Incorporated, 400 Oakwood Rd., Lake Zurich, IL 60047.

DISCLAIMER OF IMPLIED WARRANTIES

This limited warranty is in lieu of all other expressed or implied warranties, including any warranty of FITNESS FOR A PARTICULAR PURPOSE OR USE and any implied warranty of **MERCHANTABILITY** otherwise applicable to this product. ECHO and its affiliated companies shall not be liable for any special incidental or consequential damage, including lost profits. There are no warranties extended other than as provided herein. This limited warranty may be modified only by ECHO.



ECHO, INCORPORATED
400 Oakwood Road, Lake Zurich, IL 60047
www.echo-usa.com