

Subject: Spark Arrester Briggs Trimmer Kit
Kit: YH460000220
Model(s): WT-1610 and WT-1610T

 **WARNING** 

BEFORE INSPECTING OR SERVICING ANY PART OF THIS MACHINE, SHUT OFF POWER SOURCE, DISCONNECT THE SPARK PLUG WIRE FROM THE SPARK PLUG, AND MAKE SURE ALL MOVING PARTS HAVE COME TO A COMPLETE STOP.

1. Slide spark arrester (1) into exhaust.
2. Install screw (2) to secure spark arrester.

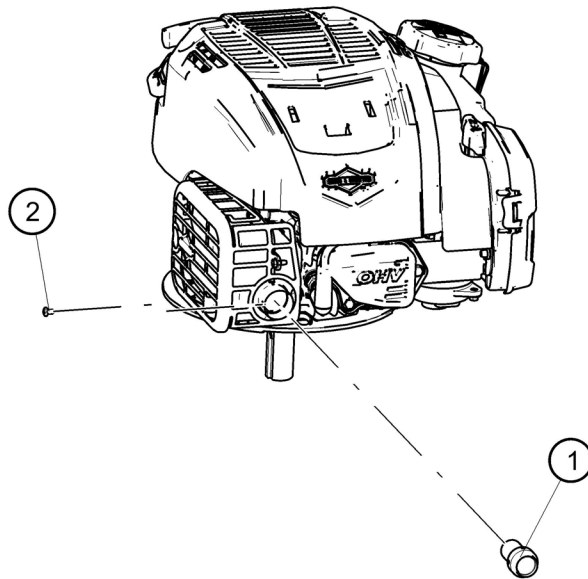

Spark Arrester Briggs Trimmer Kit YH460000220			
ITEM	PART NUMBER	DESCRIPTION	QTY
1	-	SPARK ARRESTER, BRIGGS 163CC VERT	1
2	-	SCREW, TAPPING	1

ECHO Incorporated
400 Oakwood Road
Lake Zurich, IL 60047
www.echo-usa.com
1-800-432-ECHO (3246)

Asunto: Kit de recortadora Briggs con supresor de chispas

Equipo: YH460000220

Modelo (s): WT-1610 y WT-1610T



ADVERTENCIA



ANTES DE INSPECCIONAR O REPARAR CUALQUIER PARTE DE ESTA MÁQUINA, APAGUE LA FUENTE DE ALIMENTACIÓN, DESCONECTE EL CABLE DE LA BUJÍABUJÍA Y ASEGÚRESE DE QUE TODAS LAS PIEZAS MÓVILES SE HAYAN UNA PARADA COMPLETA.

1. Deslice el parachispas (1) en el escape.
2. Instale el tornillo (2) para asegurar el parachispas.

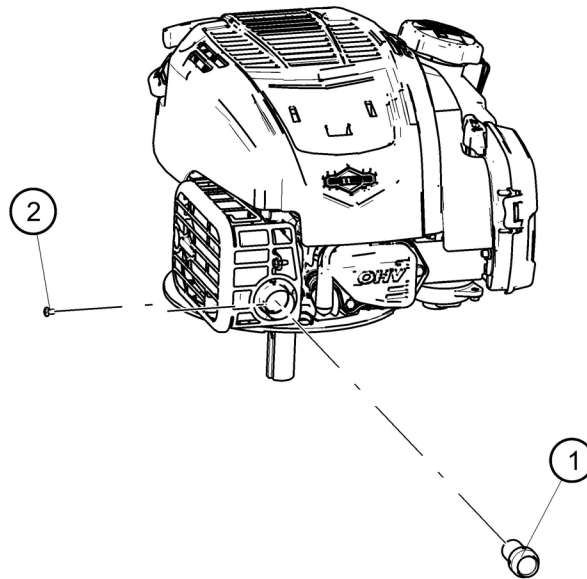

ESPAÑOL

KIT DE RECORTADORA DE CHISPAS HONDA, YH460000160			
ARTICULO	NÚMERO DE PARTE	DESCRIPCIÓN	CANTIDAD
1	-	SUPRESOR DE CHISPAS, BRIGGS 163CC VERT	1
2	-	Tornillo	1

ECHO Incorporated
400 Oakwood Road
Lake Zurich, IL 60047
www.echo-usa.com
1-800-432-ECHO (3246)

Objet: Kit de coupe-bordures Briggs pare-étincelles**Kit: YH460000220****Modèle (s): WT-1610 et WT-1610T****WARNING**

BEFORE INSPECTING OR SERVICING ANY PART OF THIS MACHINE, SHUT OFF POWER SOURCE, DISCONNECT THE SPARK PLUG WIRE FROM THE SPARK PLUG, AND MAKE SURE ALL MOVING PARTS HAVE COME TO A COMPLETE STOP.

1. Faites glisser le pare-étincelles (1) dans l'échappement.
2. Installez la vis (2) pour fixer le pare-étincelles.

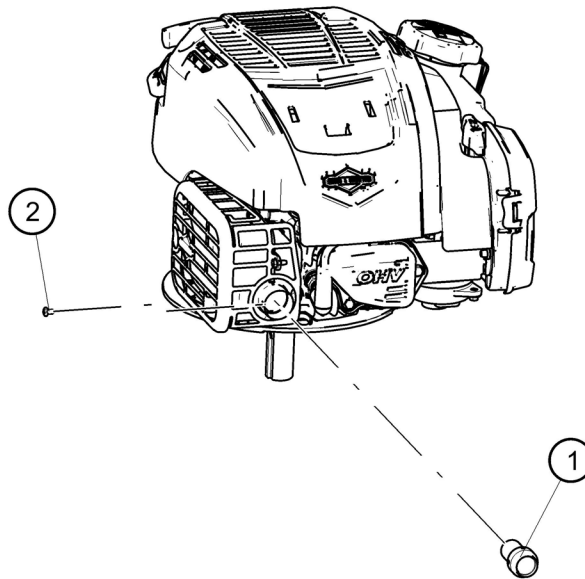

FRANÇAIS

KIT DE TRIMMER HONDA PARE-ÉTINCELLES, YH460000160

ARTICLE	NUMÉRO D'ARTICLE	LA DESCRIPTION	QUANTITÉ
1	-	PARE-ÉTINCELLES, BRIGGS 163CC VERT	1
2	-	Vis	1

ECHO Incorporated
 400 Oakwood Road
 Lake Zurich, IL 60047
 www.echo-usa.com
 1-800-432-ECHO (3246)